

## 21. Cylinder Block

### A: REMOVAL

**NOTE:**

Before conducting this procedure, drain the engine oil completely.

- 1) Remove the intake manifold. <Ref. to FU(H4SO)-11, REMOVAL, Intake Manifold.>
- 2) Remove the V-belts. <Ref. to ME(H4SO)-36, REMOVAL, V-belt.>
- 3) Remove the crank pulley. <Ref. to ME(H4SO)-38, REMOVAL, Crank Pulley.>
- 4) Remove the timing belt cover. <Ref. to ME(H4SO)-39, REMOVAL, Timing Belt Cover.>
- 5) Remove the timing belt. <Ref. to ME(H4SO)-40, REMOVAL, Timing Belt.>
- 6) Remove the cam sprocket. <Ref. to ME(H4SO)-45, REMOVAL, Cam Sprocket.>
- 7) Remove the crank sprocket. <Ref. to ME(H4SO)-46, REMOVAL, Crank Sprocket.>
- 8) Remove the generator and A/C compressor with their brackets.
- 9) Remove the rocker cover.
- 10) Remove the cylinder head bolts in alphabetical sequence shown in the figure.

**NOTE:**

Leave bolts (a) and (d) engaged by three or four threads to prevent the cylinder head from falling.

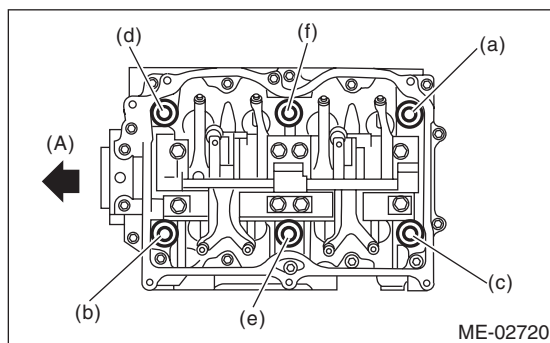

(A) Front side

- 11) While tapping the cylinder head with a plastic hammer, separate it from cylinder block.

- 12) Remove the bolts (a) and (d) to remove cylinder head.

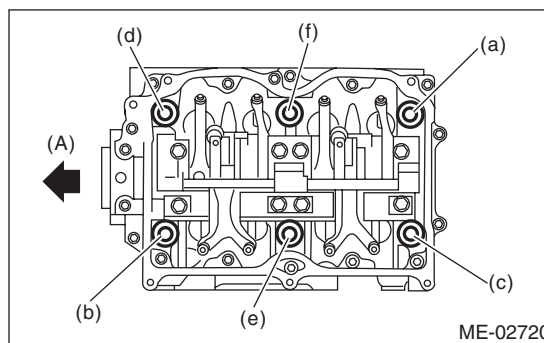

(A) Front side

- 13) Remove the cylinder head gasket.

**NOTE:**

Do not scratch the mating surface of cylinder head and cylinder block.

- 14) Similarly, remove the right side cylinder head.
- 15) Remove the clutch housing cover. (MT model)
- 16) Remove the flywheel (MT model) or drive plate (AT model).

Using the ST, lock the crankshaft.

ST 498497100 CRANKSHAFT STOPPER

- MT model

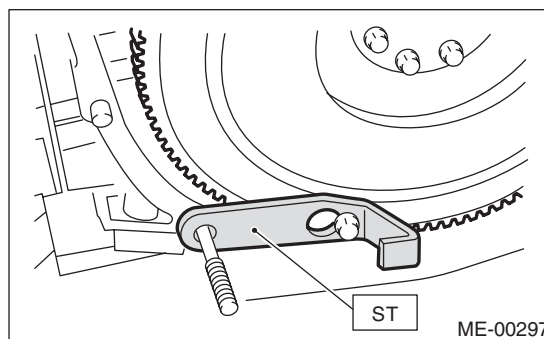

- AT model

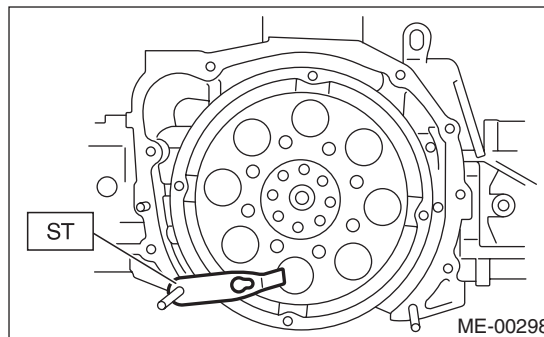

- 17) Remove the oil separator cover.
- 18) Remove the water by-pass pipe for heater.

# Cylinder Block

## MECHANICAL

19) Remove the water pump after loosening the bolts in alphabetical sequence as shown in the figure.

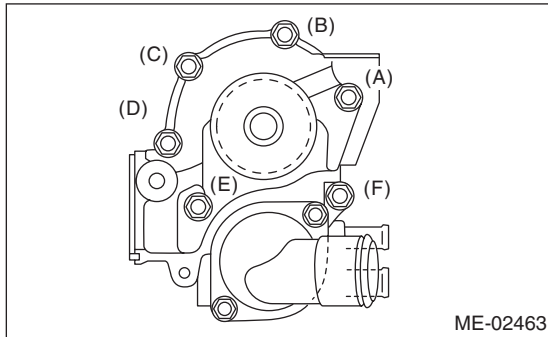

20) Remove the bolts which install oil pump onto cylinder block.

### NOTE:

When disassembling and checking the oil pump, loosen the relief valve plug before removing the oil pump.

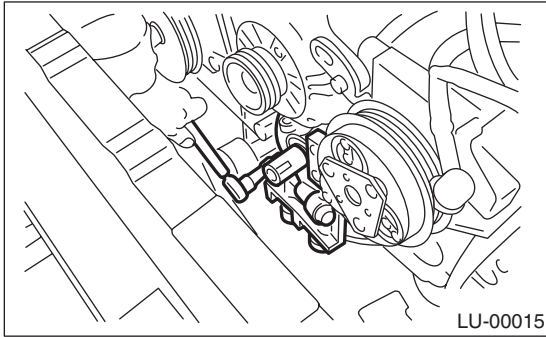

21) Remove the oil pump from cylinder block using a flat tip screwdriver.

### CAUTION:

**Be careful not to scratch the mating surface of cylinder block and oil pump.**

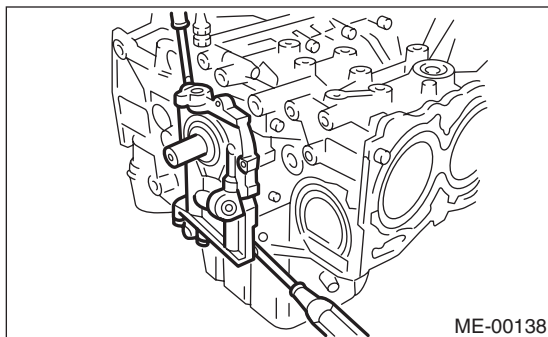

22) Remove the oil pan.

(1) Place the cylinder block to face the #2 and #4 piston side upward.

(2) Remove the bolts which secure oil pan to cylinder block.

(3) Insert an oil pan cutter blade between cylinder block-to-oil pan clearance and remove the oil pan.

### NOTE:

Do not use a screwdriver or similar tools in place of oil pan cutter.

23) Remove the oil strainer stay.

24) Remove the oil strainer.

25) Remove the baffle plate.

26) Remove the oil filter. <Ref. to LU(H4SO)-19, REMOVAL, Engine Oil Filter.>

# Cylinder Block

27) Remove the water pipe.

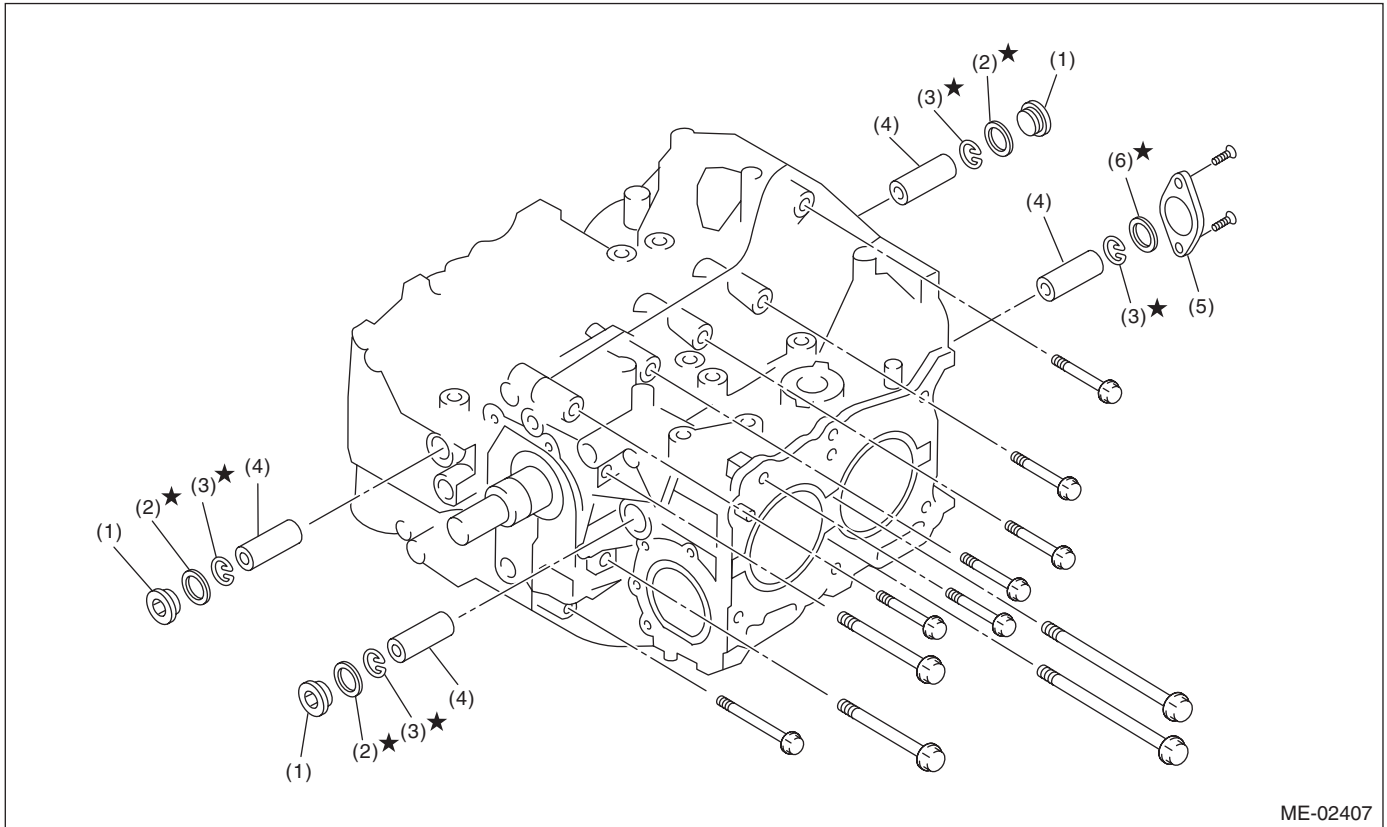
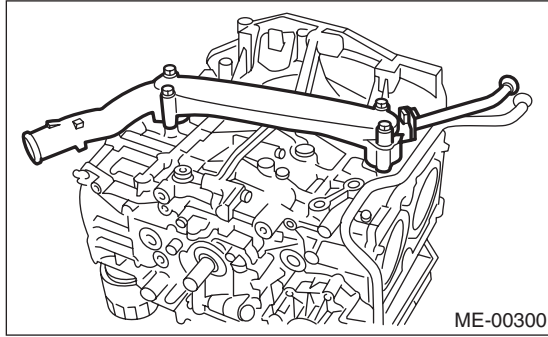

- |                       |                |                        |
|-----------------------|----------------|------------------------|
| (1) Service hole plug | (3) Snap ring  | (5) Service hole cover |
| (2) Gasket            | (4) Piston pin | (6) O-ring             |

28) Remove the service hole cover and service hole plugs using a hexagon wrench [14 mm].

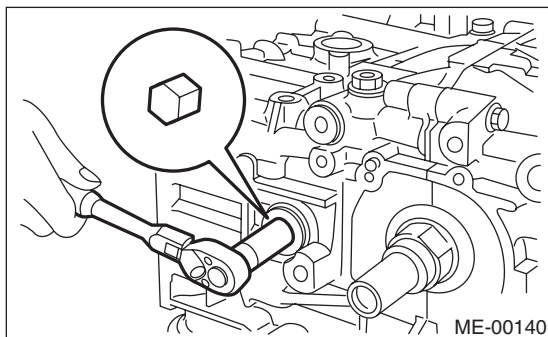

# Cylinder Block

## MECHANICAL

---

29) Rotate the crankshaft to bring #1 and #2 pistons to bottom dead center position, then remove the piston snap ring through service hole of #1 and #2 cylinders.

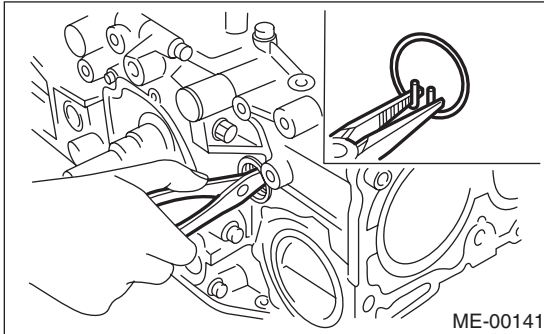

30) Draw out the piston pin from #1 and #2 pistons using ST.

ST 499097700 PISTON PIN REMOVER

### NOTE:

Be careful not to confuse the original combination of piston, piston pin and cylinder.

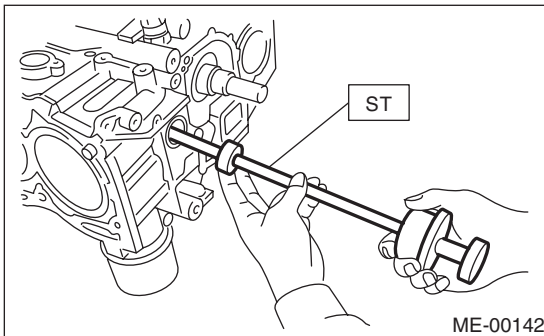

31) Similarly remove the piston pins from #3 and #4 pistons.

32) Remove the bolts which connect cylinder block on the side of #2 and #4 cylinders.

33) Back off the bolts which connect cylinder block on the side of #1 and #3 cylinders two or three turns.

34) Set up the cylinder block so that #1 and #3 cylinders are on the upper side, then remove the cylinder block connecting bolts.

35) Separate the cylinder block (RH) and (LH).

**NOTE:**

When separating the cylinder block, do not allow the connecting rod to fall or damage the cylinder block.

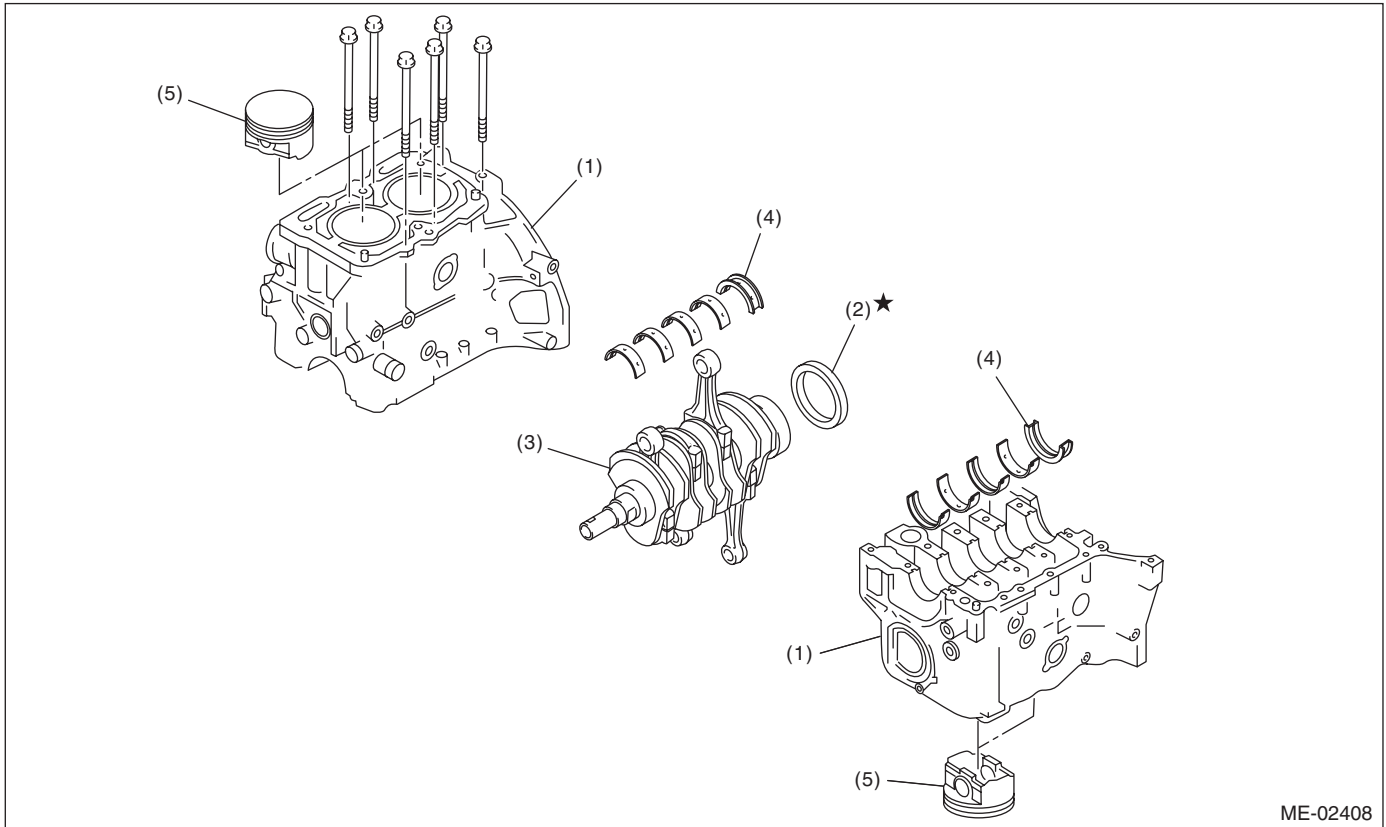

ME-02408

- |                    |                        |            |
|--------------------|------------------------|------------|
| (1) Cylinder block | (3) Crankshaft         | (5) Piston |
| (2) Rear oil seal  | (4) Crankshaft bearing |            |

36) Remove the rear oil seal.

37) Remove the crankshaft together with connecting rod.

38) Remove the crankshaft bearings from cylinder block using a hammer handle.

**NOTE:**

Be careful not to confuse the crankshaft bearing combination. Press the bearing at the end opposite to locking lip.

39) Draw out each piston from cylinder block using wooden bar or hammer handle.

**NOTE:**

Be careful not to confuse the original combination of piston and cylinder.

# Cylinder Block

MECHANICAL

## B: INSTALLATION

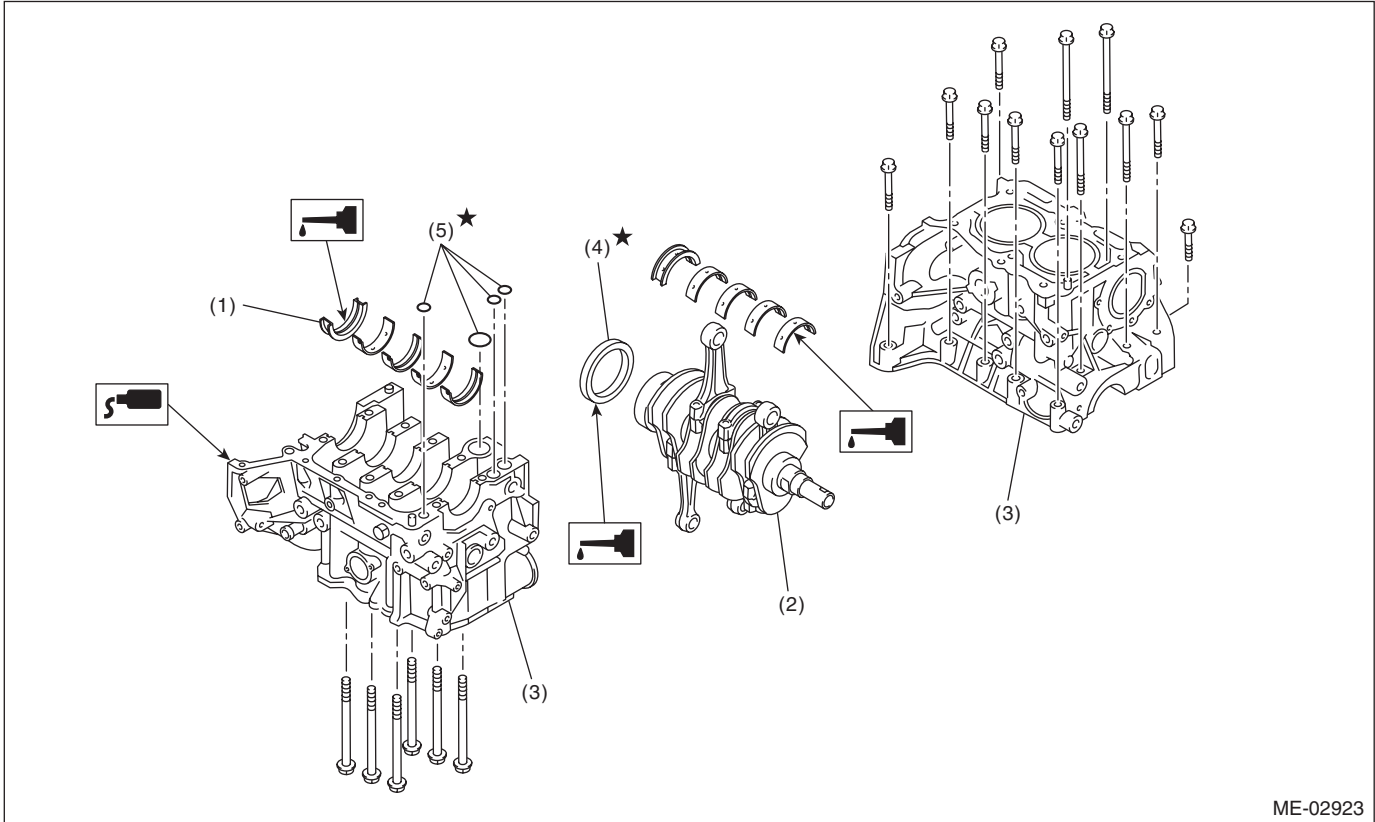

- (1) Crankshaft bearing  
(2) Crankshaft  
(3) Cylinder block  
(4) Rear oil seal

- (5) O-ring

### NOTE:

Remove oil on the mating surface of bearing and cylinder block before installation. Apply engine oil to crankshaft pins.

1) Position the crankshaft and O-rings on the #1 and #3 cylinder block.

2) Apply liquid gasket to the mating surface of #1 and #3 cylinder block, and position #2 and #4 cylinder block.

### **Liquid gasket:**

**Three bond 1215 (Part No. 004403007) or equivalent**

### NOTE:

Do not allow liquid gasket to jut into O-ring grooves, oil passages, bearing grooves, etc.

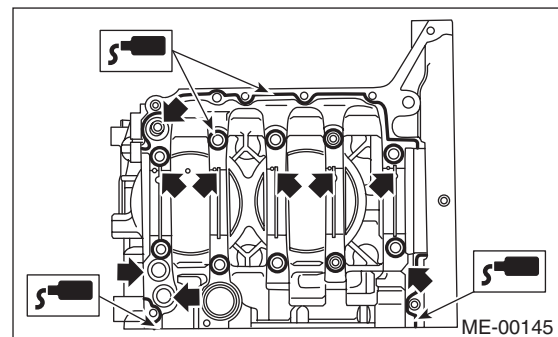

3) Apply a coat of engine oil to the washer and bolt thread.

# Cylinder Block

MECHANICAL

4) Tighten the 10 mm cylinder block connecting bolts on LH side (A — D) in alphabetical sequence.

**Tightening torque:**

**9.75 N·m (1.0 kgf·m, 7.2 ft·lb)**

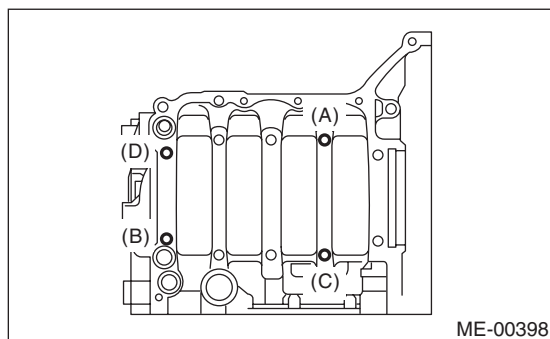

5) Tighten the 10 mm cylinder block connecting bolts on RH side (E — J) in alphabetical sequence.

**Tightening torque:**

**9.75 N·m (1.0 kgf·m, 7.2 ft·lb)**

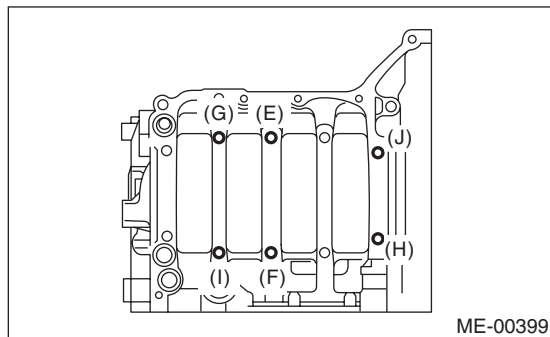

6) Further tighten the LH side bolts (A — D) in alphabetical sequence.

**Tightening torque:**

**18 N·m (1.8 kgf·m, 13 ft·lb)**

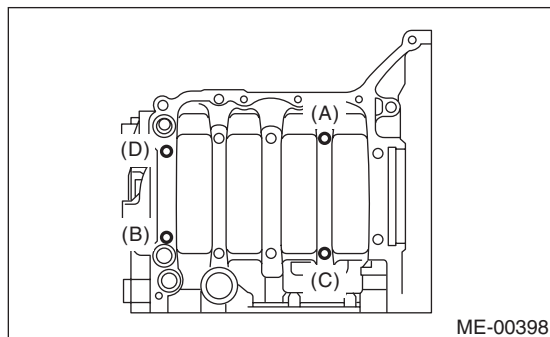

7) Further tighten the RH side bolts (E — J) in alphabetical sequence.

**Tightening torque:**

**18 N·m (1.8 kgf·m, 13 ft·lb)**

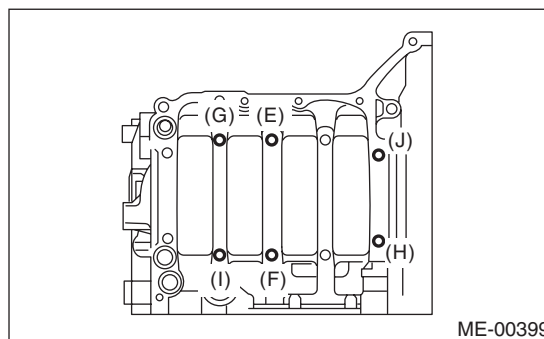

8) Further tighten the LH side bolts (A — D) in alphabetical sequence.

- (A), (C): Angle tightening

**Tightening angle:**

**90°**

- (B), (D): Torque tightening

**Tightening torque:**

**40 N·m (4.1 kgf·m, 29.6 ft·lb)**

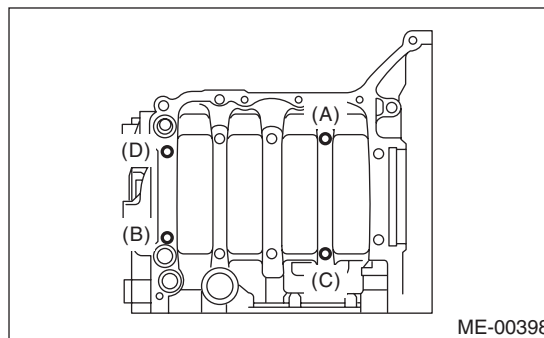

9) Tighten the RH side bolts (E — J) 90° further in alphabetical sequence.

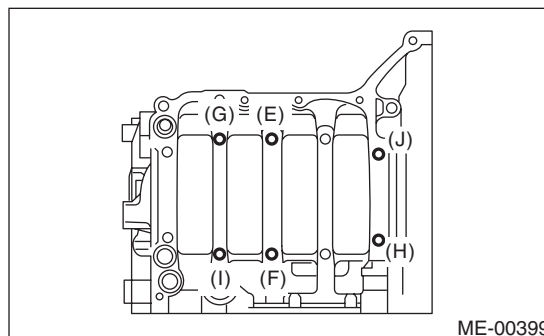

# Cylinder Block

## MECHANICAL

10) Tighten the 8 mm and 6 mm cylinder block connecting bolts on LH side (A — H) in alphabetical sequence.

### Tightening torque:

(A) — (G): 25 N·m (2.5 kgf·m, 18.1 ft·lb)

(H): 6.4 N·m (0.65 kgf·m, 4.7 ft·lb)

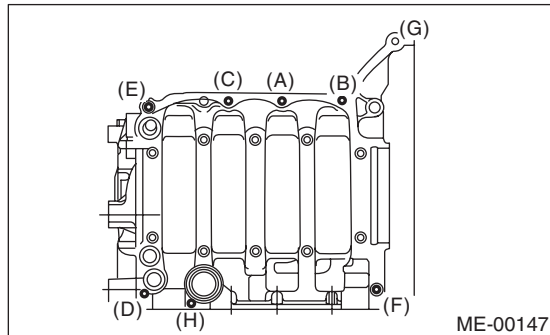

11) Apply engine oil to the oil seal periphery, and install the rear oil seal using ST1 and ST2.

### NOTE:

Use a new rear oil seal.

ST1 499597100 OIL SEAL GUIDE

ST2 499587200 OIL SEAL INSTALLER

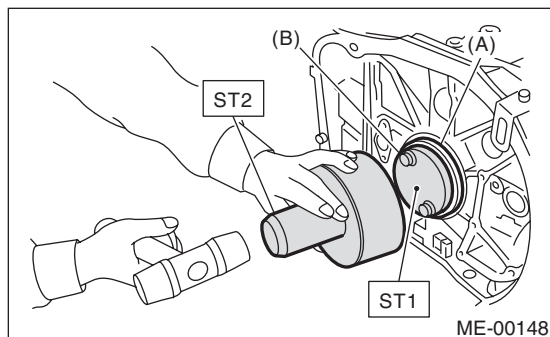

(A) Rear oil seal

(B) Flywheel attaching bolt

12) Position the top ring gap at (A) or (B) in the figure.

### NOTE:

Assemble so that the piston ring mark “R” faces the upper side of the piston.

13) Position the second ring gap at 180° on the reverse side the top ring gap.

### NOTE:

Assemble so that the piston ring mark “R” faces the upper side of the piston.

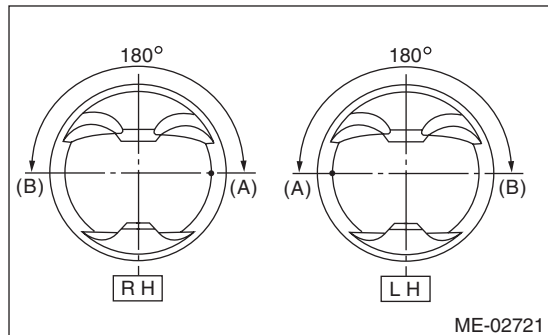

14) Position the upper rail gap at (C) in the figure.

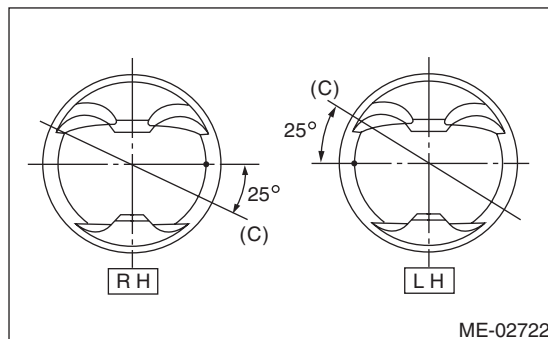

15) Align the upper rail spin stopper (E) to the side hole (D) on the piston.

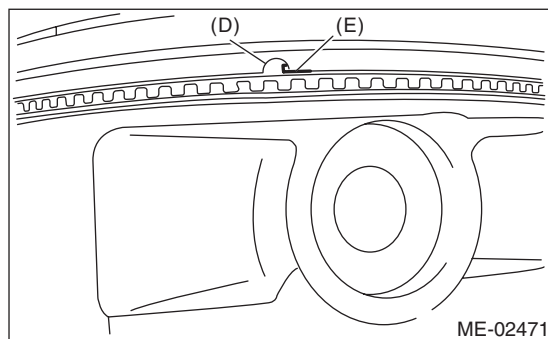

16) Position the expander gap at (F) in the figure.

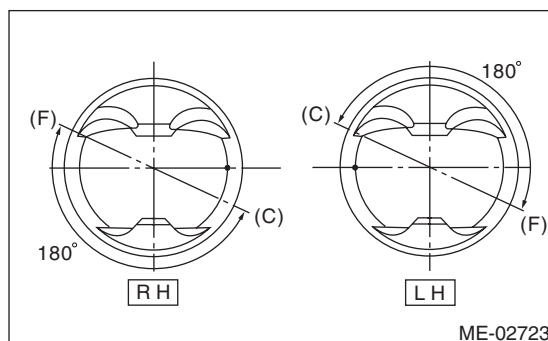



# Cylinder Block

MECHANICAL

17) Position the lower rail gap at (G) in the figure.

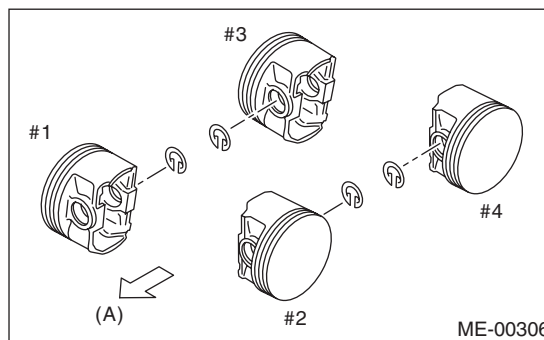
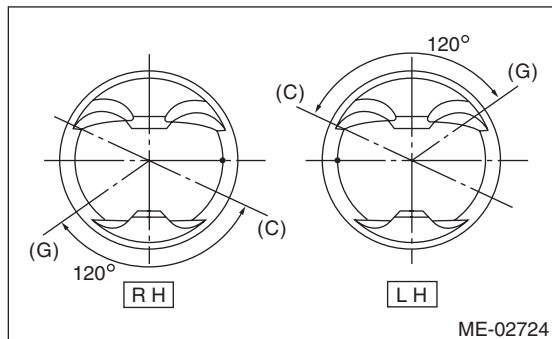

(A) Front side

**CAUTION:**

- Make sure ring gaps do not face the same direction.
- Make sure ring gaps are not within the piston skirt area.

**CAUTION:**

Piston front mark faces towards the front of engine.

18) Install the snap ring.

Install the snap rings in the piston holes located opposite to the service holes in cylinder block when positioning all pistons in corresponding cylinders.

**NOTE:**

Use new snap rings.

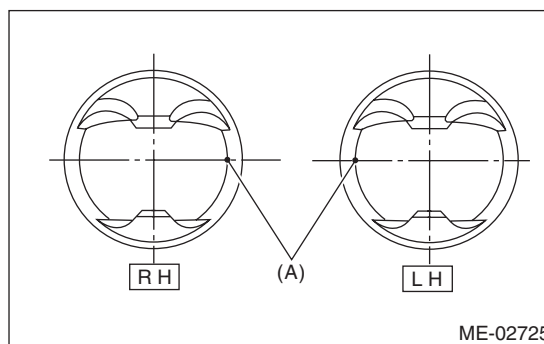

(A) Front mark

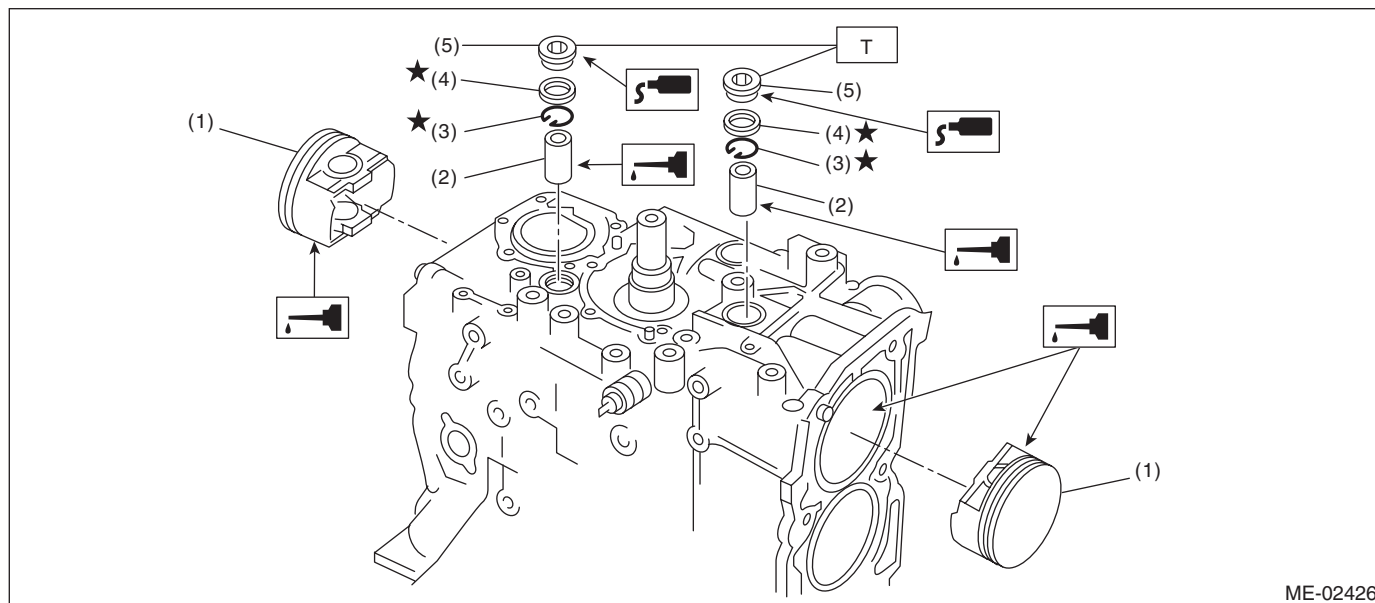

- |                |                       |
|----------------|-----------------------|
| (1) Piston     | (4) Gasket            |
| (2) Piston pin | (5) Service hole plug |
| (3) Snap ring  |                       |

**Tightening torque: N·m (kgf·m, ft·lb)**  
**T: 70 (7.1, 50.6)**

# Cylinder Block

## MECHANICAL

### 19) Install the piston.

- (1) Place the cylinder block to face the #1 and #2 cylinder side upward.
- (2) Using the ST1, turn the crankshaft so that #1 and #2 connecting rods are set at bottom dead center.

ST1 499987500 CRANKSHAFT SOCKET

- (3) Apply a coat of engine oil to the pistons and cylinders and insert pistons in their cylinders using ST2.

ST2 498747300 PISTON GUIDE

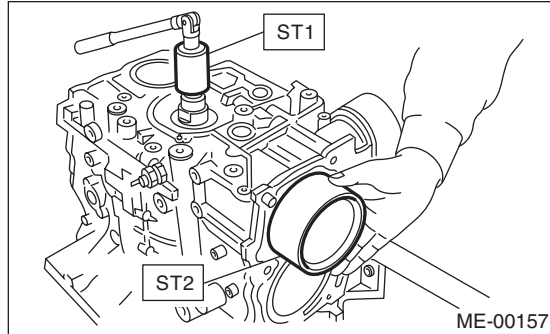

### 20) Install the piston pin.

- (1) Apply a coat of engine oil to ST3.
- (2) Insert ST3 into the service hole to align piston pin hole with connecting rod small end.

ST3 499017100 PISTON PIN GUIDE

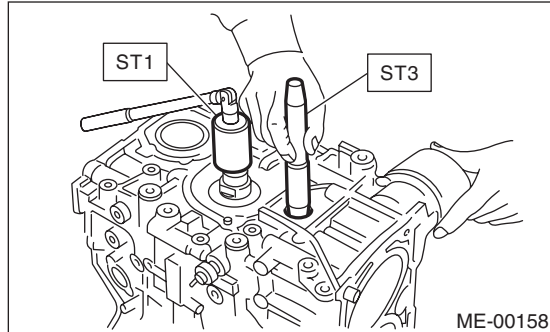

- (3) Apply a coat of engine oil to piston pin, and insert the piston pin into piston and connecting rod through service hole.
- (4) Install the snap ring.

### NOTE:

Use new snap rings.

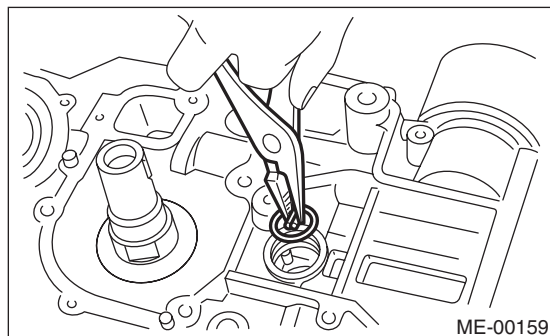

- (5) Apply liquid gasket around the service hole plug.

### Liquid gasket:

**Three bond 1105 (Part No. 004403010) or equivalent**

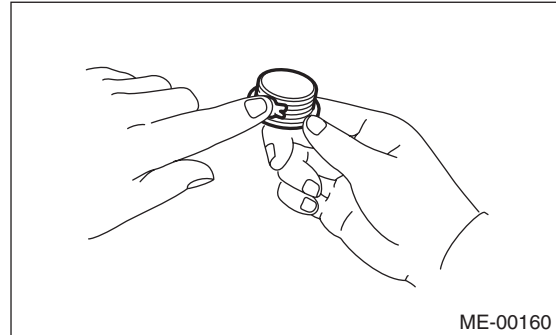

# Cylinder Block

MECHANICAL

(6) Install the service hole plug and gasket.

**NOTE:**

Use a new gasket.

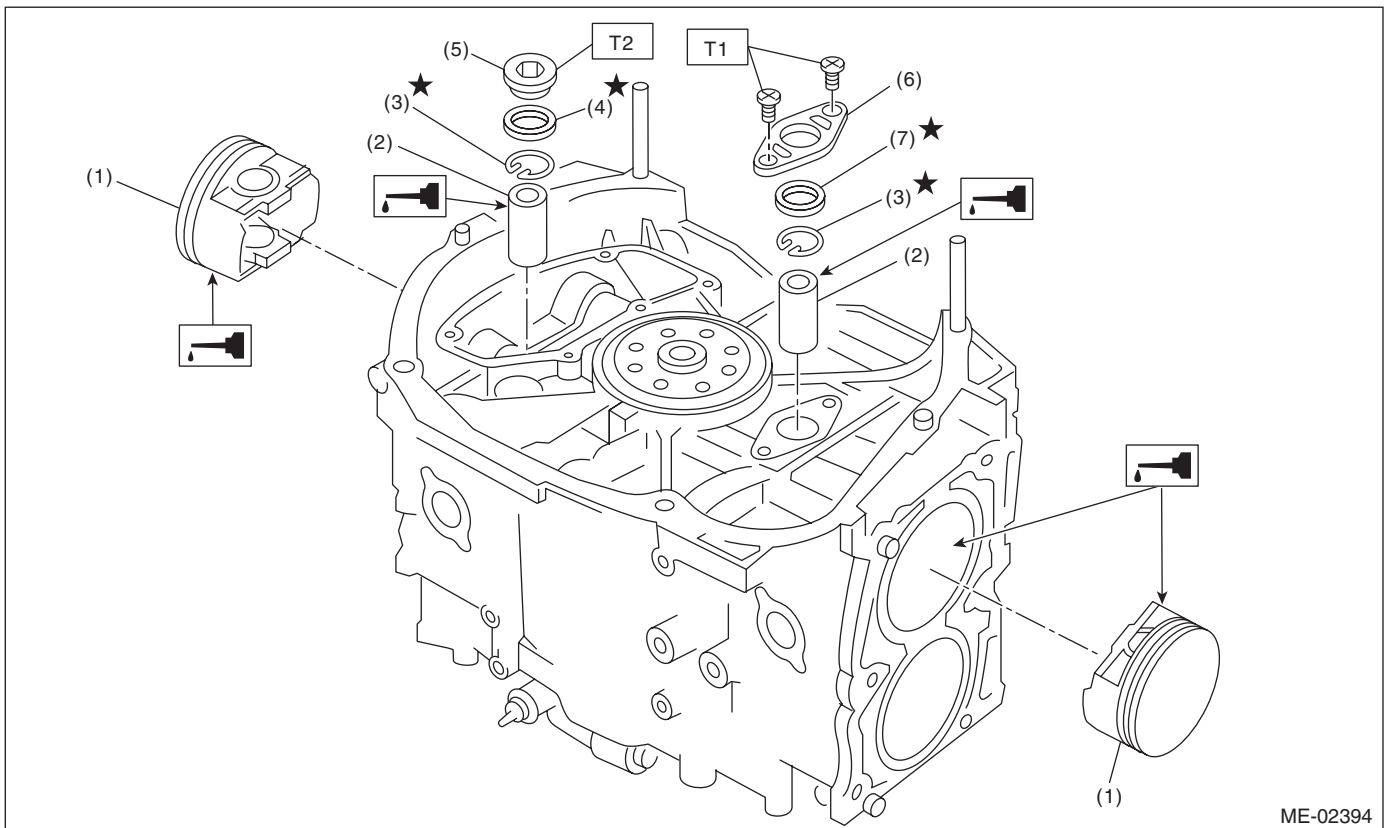
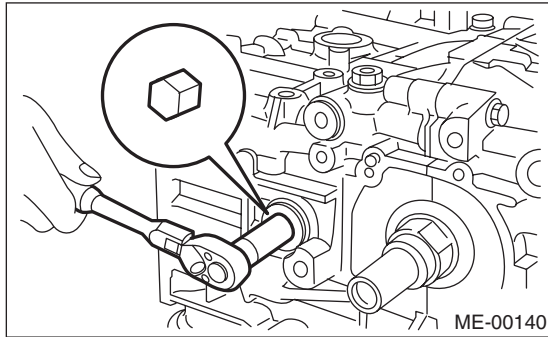

- |                |                        |
|----------------|------------------------|
| (1) Piston     | (5) Service hole plug  |
| (2) Piston pin | (6) Service hole cover |
| (3) Snap ring  | (7) O-ring             |
| (4) Gasket     |                        |

**Tightening torque: N-m (kgf-m, ft-lb)**

**T1: 6.4 (0.65, 4.7)**

**T2: 70 (7.1, 50.6)**

(7) Place the cylinder block to face the #3 and #4 cylinder side upward. Following the same procedures as used for #1 and #2 cylinders, install the pistons and piston pins.

# Cylinder Block

## MECHANICAL

21) Install the water pipe.

**Tightening torque:**

**6.4 N·m (0.65 kgf-m, 4.7 ft-lb)**

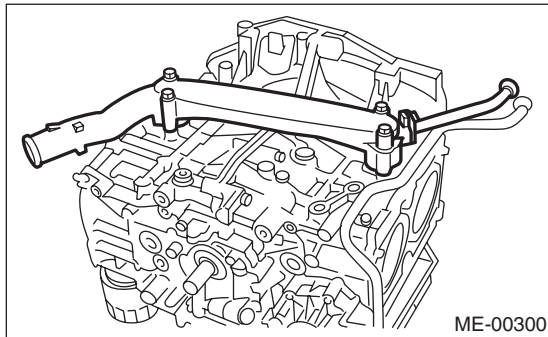

22) Install the baffle plate.

**Tightening torque:**

**6.4 N·m (0.65 kgf-m, 4.7 ft-lb)**

23) Install the oil strainer and O-ring.

**Tightening torque:**

**9.75 N·m (1.0 kgf-m, 7.2 ft-lb)**

24) Install the oil strainer stay.

25) Apply liquid gasket to the mating surfaces, and install the oil pan.

**Liquid gasket:**

**Three bond 1207C (Part No.004403012) or equivalent**

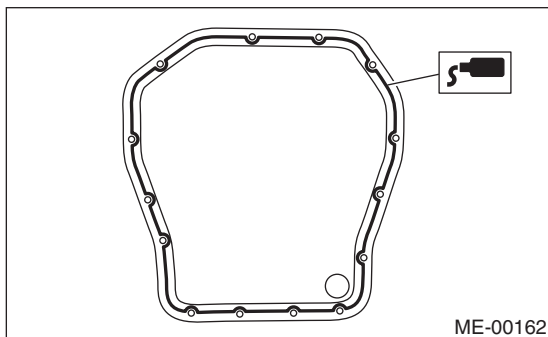

26) Apply liquid gasket to the mating surfaces and the threaded portion of bolt (A) shown in the figure, and then install the oil separator cover.

**Liquid gasket:**

• **Mating surface**

**Three bond 1207C (Part No.004403012) or equivalent**

• **(A) bolt threads**

**Three bond 1324 (Part No.004403042) or equivalent**

**Tightening torque:**

**6.4 N·m (0.65 kgf-m, 4.7 ft-lb)**

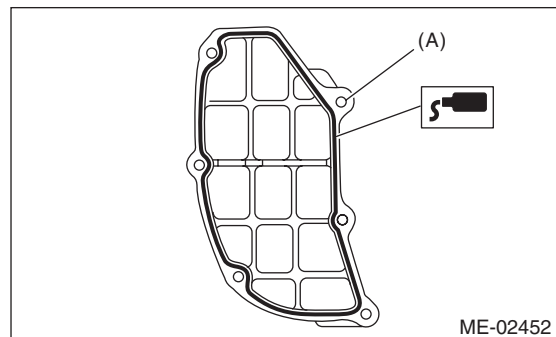

27) Install the flywheel. (MT model)

<Ref. to CL-13, INSTALLATION, Flywheel.>

To lock the crankshaft, use the ST.

ST 498497100 CRANKSHAFT STOPPER

**Tightening torque:**

**72 N·m (7.3 kgf-m, 52.8 ft-lb)**

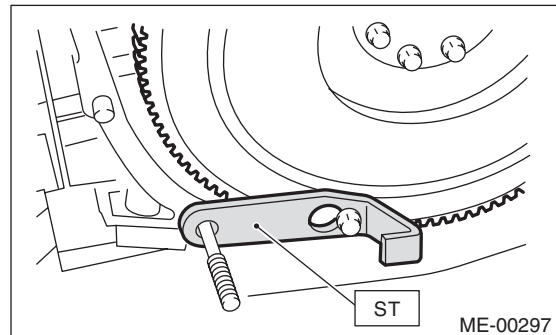

# Cylinder Block

MECHANICAL

28) Install the drive plate.  
To lock the crankshaft, use the ST.  
ST 498497100 CRANKSHAFT STOPPER

**Tightening torque:**  
**72 N·m (7.3 kgf·m, 52.8 ft·lb)**

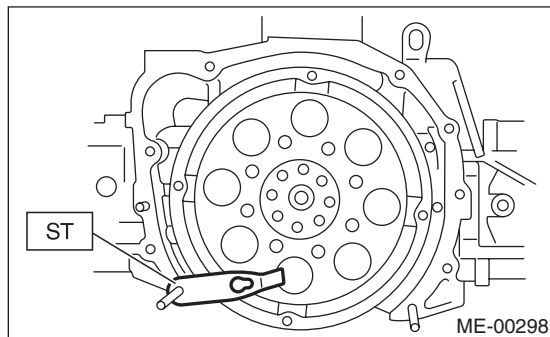

29) Install the housing cover.

30) Installation of oil pump:

(1) Discard the front oil seal after removal. Replace with a new part using ST.

ST 499587100 OIL SEAL INSTALLER

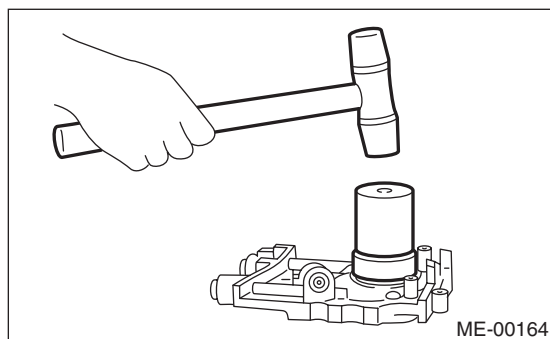

(2) Apply liquid gasket to the matching surface of oil pump.

**Liquid gasket:**  
**Three bond 1215 (Part No. 004403007) or equivalent**

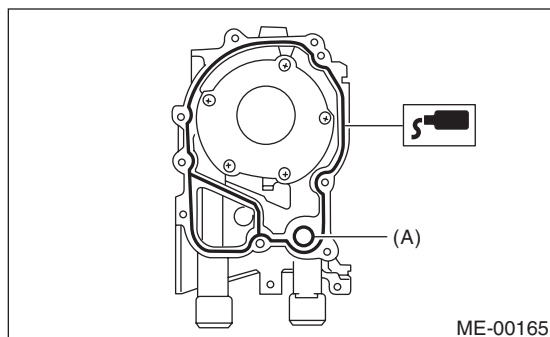

(A) O-ring

(3) Apply a coat of engine oil to the inside of oil seal.

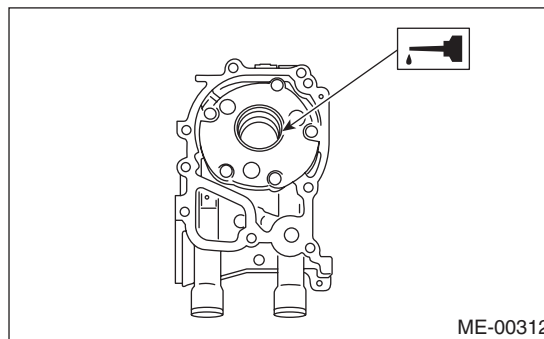

(4) Install the oil pump to cylinder block. Be careful not to damage the oil seal during installation.

### CAUTION:

- Make sure the oil seal lip is not folded.
- Do not forget to install the O-ring and seal when installing oil pump.

(5) Apply liquid gasket to the three bolts thread shown in figure.

### Liquid gasket:

**Three bond 1324 (Part No.004403042) or equivalent**

### Tightening torque:

**T: 6.4 N·m (0.65 kgf·m, 4.7 ft·lb)**

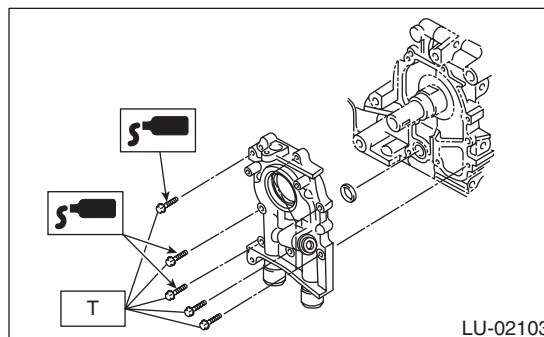

# Cylinder Block

## MECHANICAL

---

31) Install the water pump and gasket.

**Tightening torque:**

**First: 12 N·m (1.2 kgf-m, 8.7 ft-lb)**

**Second: 12 N·m (1.2 kgf-m, 8.7 ft-lb)**

**CAUTION:**

- Be sure to use a new gasket.
- When installing the water pump, tighten bolts in two stages in alphabetical sequence as shown in the figure.

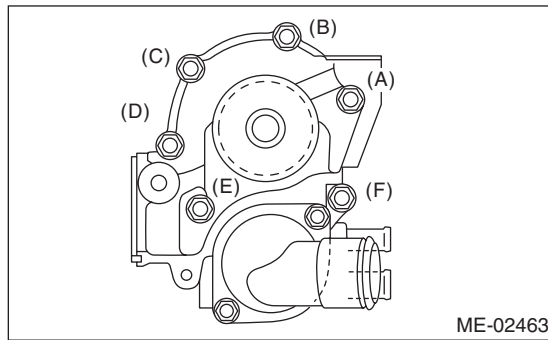

32) Install the water by-pass pipe for heater.

33) Install the oil filter.

<Ref. to LU(H4SO)-19, INSTALLATION, Engine Oil Filter.>

34) Tighten the cylinder head bolts. <Ref. to ME(H4SO)-54, INSTALLATION, Cylinder Head.>

35) Install the oil level gauge guide and tighten the bolts. (LH side only)

36) Install the rocker cover and rocker cover gasket.

**NOTE:**

Use a new rocker cover gasket.

37) Install the crank sprocket.

<Ref. to ME(H4SO)-46, INSTALLATION, Crank Sprocket.>

38) Install the cam sprocket. <Ref. to ME(H4SO)-45, INSTALLATION, Cam Sprocket.>

39) Install the timing belt. <Ref. to ME(H4SO)-41, INSTALLATION, Timing Belt.>

40) Install the timing belt cover.

<Ref. to ME(H4SO)-39, INSTALLATION, Timing Belt Cover.>

41) Install the crank pulley. <Ref. to ME(H4SO)-38, INSTALLATION, Crank Pulley.>

42) Install the generator and A/C compressor brackets on cylinder head.

43) Install the V-belts. <Ref. to ME(H4SO)-36, INSTALLATION, V-belt.>

44) Install the intake manifold.

<Ref. to FU(H4SO)-13, INSTALLATION, Intake Manifold.>

## C: DISASSEMBLY

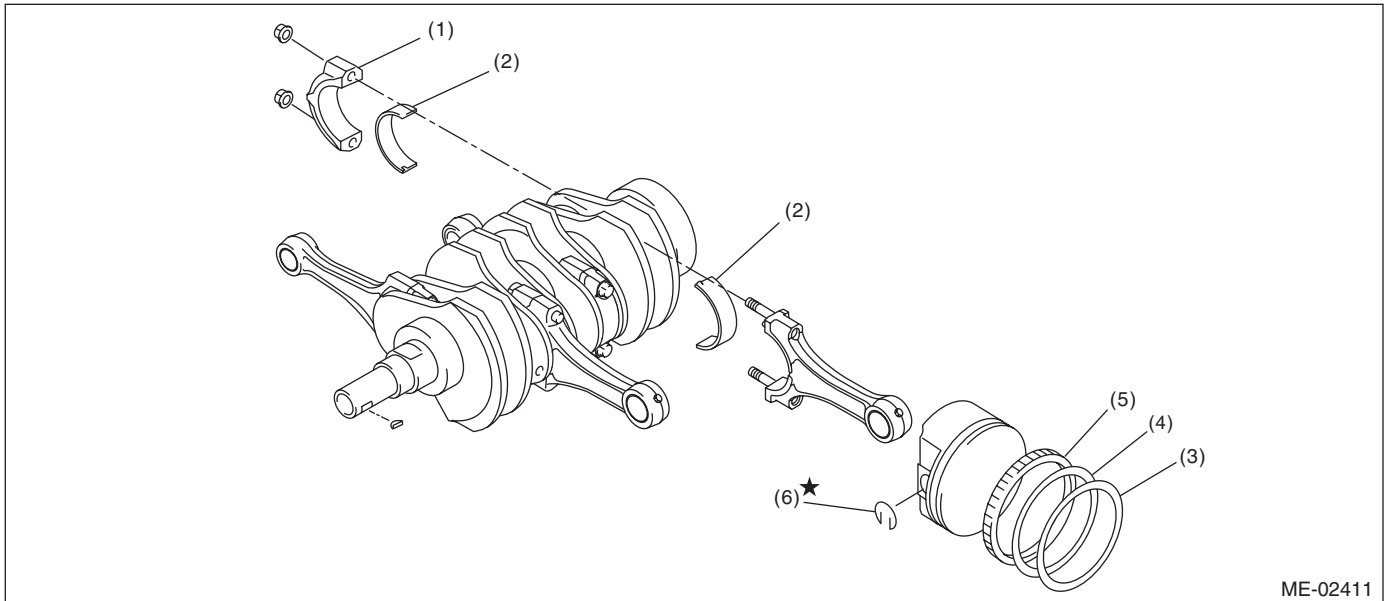

ME-02411

- |                            |                 |               |
|----------------------------|-----------------|---------------|
| (1) Connecting rod cap     | (3) Top ring    | (5) Oil ring  |
| (2) Connecting rod bearing | (4) Second ring | (6) Snap ring |

- 1) Remove the connecting rod cap.
- 2) Remove the connecting rod bearing.

**NOTE:**

Arrange the removed connecting rod, connecting rod cap and bearing in order, to prevent confusion.

- 3) Remove the piston rings using piston ring expander.
- 4) Remove the oil ring by hand.

**NOTE:**

Arrange the removed piston rings in proper order, to prevent confusion.

- 5) Remove the snap ring.

# Cylinder Block

MECHANICAL

## D: ASSEMBLY

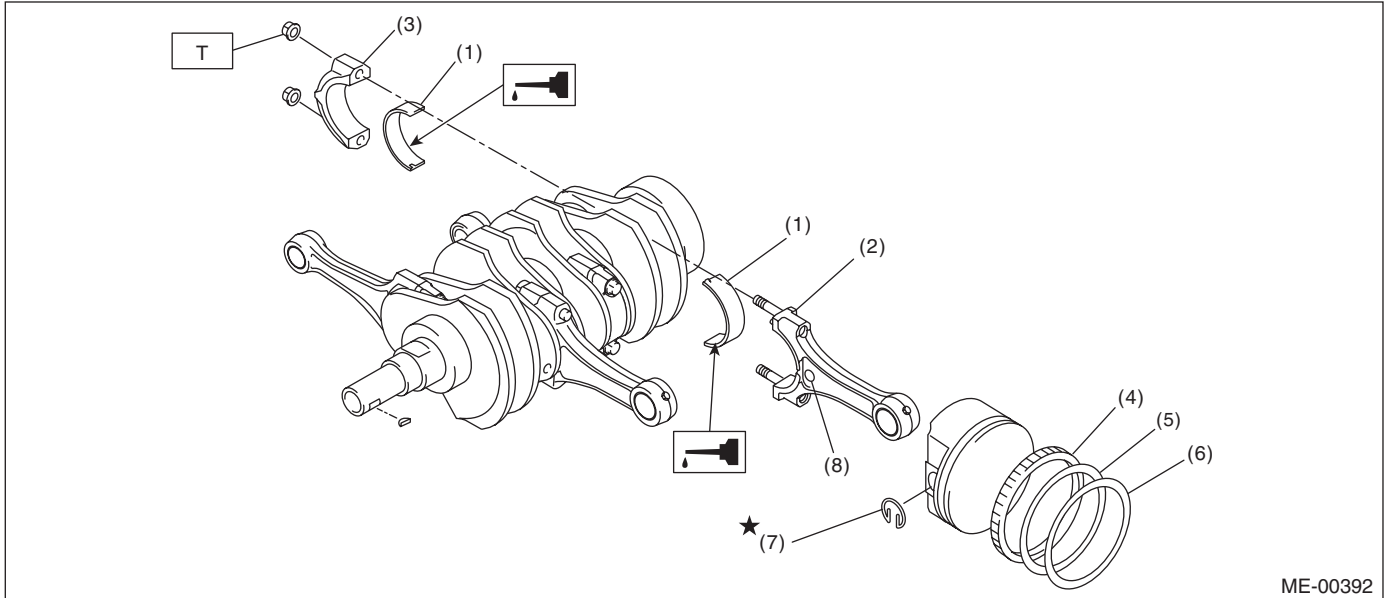

- |                            |                 |
|----------------------------|-----------------|
| (1) Connecting rod bearing | (5) Second ring |
| (2) Connecting rod         | (6) Top ring    |
| (3) Connecting rod cap     | (7) Snap ring   |
| (4) Oil ring               | (8) Side mark   |

**Tightening torque: N·m (kgf-m, ft-lb)**  
**T: 45 (4.6, 33.3)**

1) Apply oil to the surfaces of the connecting rod bearings.

2) Install the connecting rod bearings on connecting rods and connecting rod caps.

3) Position each connecting rod with the marking side facing forward, and install it.

4) Install the connecting rod cap with connecting rod nut.

Make sure the arrow on connecting rod cap faces toward front during installation.

### CAUTION:

- Each connecting rod has its own mating cap. Make sure that they are assembled correctly by checking their matching number.

- When tightening the connecting rod nuts, apply oil on the threads.

5) Install the expander, lower rail and upper rail in this order by hand. Install the second ring and top ring along with the piston ring expander.

## E: INSPECTION

### 1. CYLINDER BLOCK

1) Visually check for cracks and damage. Especially, inspect the important parts using liquid penetrant tester.

2) Check the oil passages for clogging.

3) Inspect the cylinder block surface that mates with cylinder head for warping by using a straight edge, and correct by grinding if necessary.

#### Warping limit:

**0.025 mm (0.00098 in)**

#### Grinding limit:

**0.1 mm (0.004 in)**

#### Standard height of cylinder block:

**201.0 mm (7.91 in)**



## 2. CYLINDER AND PISTON

1) The cylinder bore size is stamped on the cylinder block front upper surface.

**NOTE:**

- Measurement should be performed at a temperature of 20°C (68°F).
- Standard sized pistons are classified into two grades, "A" and "B". These grades should be used as guide lines in selecting a standard piston.

**Standard diameter:**

**A: 99.505 — 99.515 mm (3.9175 — 3.9179 in)**

**B: 99.495 — 99.505 mm (3.9171 — 3.9175 in)**

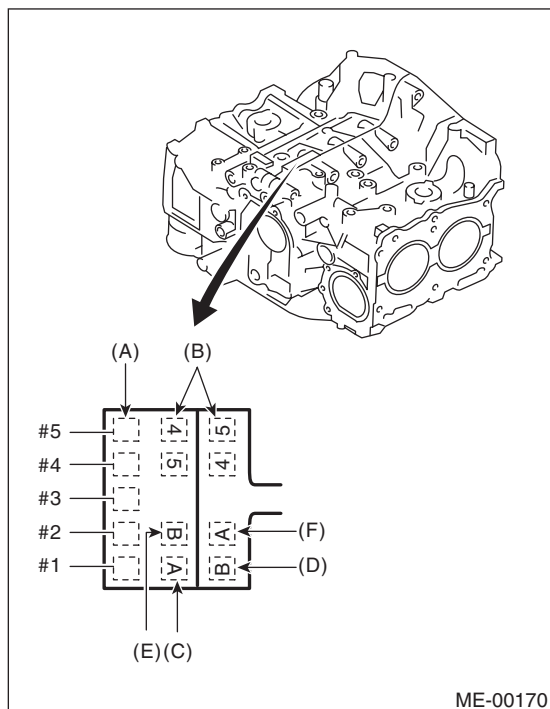

- (A) Main journal size mark
- (B) Cylinder block (RH)-(LH) combination mark
- (C) #1 cylinder bore size mark
- (D) #2 cylinder bore size mark
- (E) #3 cylinder bore size mark
- (F) #4 cylinder bore size mark

2) How to measure the inner diameter of each cylinder

Measure the inner diameter of each cylinder in both the thrust and piston pin directions at the heights as shown in the figure, using a cylinder bore gauge.

**NOTE:**

Measurement should be performed at a temperature of 20°C (68°F).

**Taper:**

**Standard:**

**0.015 mm (0.0006 in)**

**Out-of-roundness:**

**Standard:**

**0.010 mm (0.0004 in)**

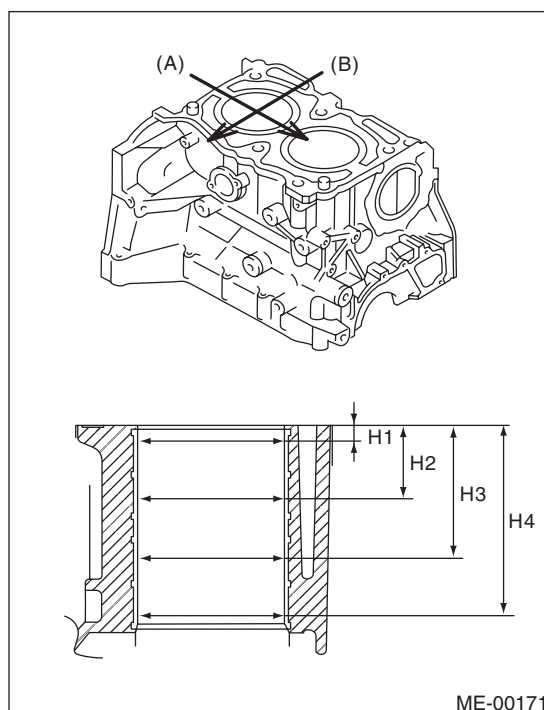

- (A) Piston pin direction
- (B) Thrust direction
- H1 10 mm (0.39 in)
- H2 45 mm (1.77 in)
- H3 80 mm (3.15 in)
- H4 115 mm (4.53 in)

3) When the piston is to be replaced due to general or cylinder wear, determine a suitable sized piston by measuring the piston clearance.

# Cylinder Block

## MECHANICAL

4) How to measure the outer diameter of each cylinder:

Measure the outer diameter of each piston at the height as shown in the figure. (Thrust direction)

NOTE:

Measurement should be performed at a temperature of 20°C (68°F).

**Piston grade point H:**  
**38.2 mm (1.504 in)**

**Standard:**

**A: 99.505 — 99.515 mm (3.9175 — 3.9179 in)**

**B: 99.495 — 99.505 mm (3.9171 — 3.9175 in)**

**0.25 mm (0.0098 in) oversize:**

**99.745 — 99.765 mm (3.9270 — 3.9278 in)**

**0.50 mm (0.0197 in) oversize:**

**99.995 — 100.015 mm (3.9368 — 3.9376 in)**

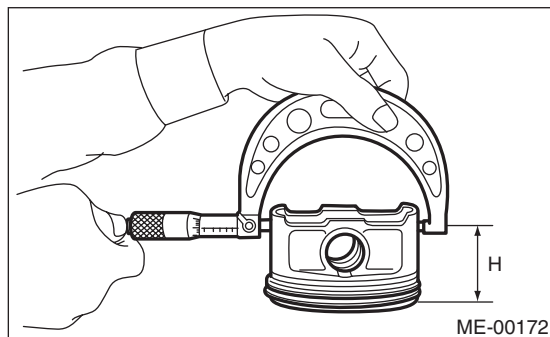

5) Calculate the clearance between cylinder and piston.

NOTE:

Measurement should be performed at a temperature of 20°C (68°F).

**Cylinder to piston clearance at 20°C (68°F):**

**Standard:**

**-0.010 — 0.010 mm (-0.00039 — 0.00039 in)**

6) Boring and honing

(1) If any of the measured value of taper, out-of-roundness or cylinder-to-piston clearance is not standard or if there is any damage on the cylinder wall, rebore it to use an oversize piston.

**CAUTION:**

**When any of the cylinders needs reboring, all other cylinders must be bored at the same time, and use oversize pistons. Do not perform boring on one cylinder only. Nor use an oversize piston for one cylinder only.**

(2) If the cylinder inner diameter exceeds the limit after boring and honing, replace the cylinder block.

**Limit of cylinder inner diameter:**  
**100.005 mm (3.9372 in)**

NOTE:

Immediately after reboring, the cylinder diameter may differ from its real diameter due to temperature rise. Thus, pay attention when measuring the cylinder diameter.

### 3. PISTON AND PISTON PIN

1) Check the pistons and piston pins for damage, cracks and wear, and the piston ring grooves for wear and damage. Replace if faulty.

2) Measure the piston-to-cylinder clearance at each cylinder. <Ref. to ME(H4SO)-77, CYLINDER AND PISTON, INSPECTION, Cylinder Block.> If any of the clearances is not within the standard value, replace the piston and bore the cylinder to enable use of an oversized piston.

3) Make sure that the piston pin can be inserted into the piston pin hole with a thumb at 20°C (68°F). Replace if faulty.

**Clearance between piston hole and piston pin:**

**Standard:**

**0.004 — 0.008 mm (0.0002 — 0.0003 in)**

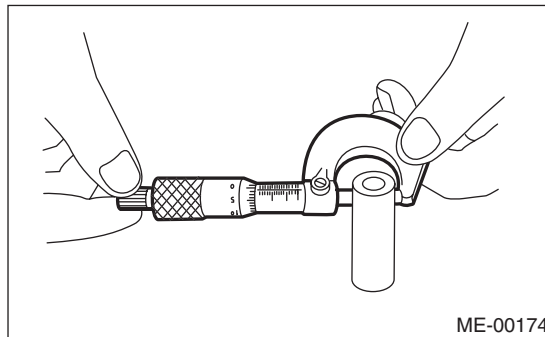
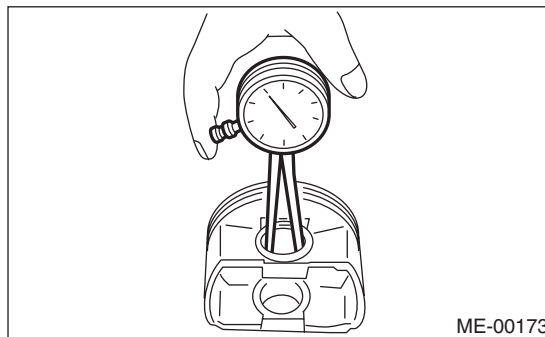

4) Check the snap ring installation groove (A) on the piston for burr. If necessary, remove burr from the groove so that the piston pin can lightly move.

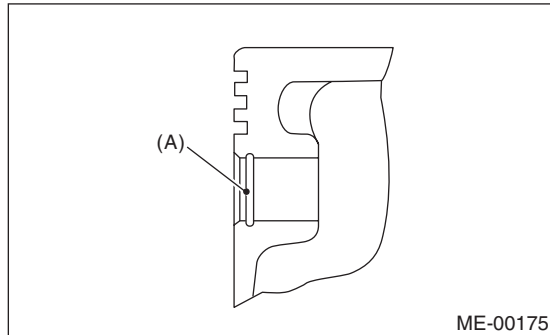

5) Check the piston pin snap ring for distortion, cracks and wear.

## 4. PISTON RING

1) If the piston ring is broken, damaged or worn, or if its tension is insufficient, or when the piston is replaced, replace the piston ring with a new part of the same size as the piston.

### CAUTION:

- Marks are displayed on the end of top and second rings. When installing the rings to piston, face these marks upward.
- Oil ring consists of the upper rail, expander and lower rail. Be careful about the direction of rail when installing the oil ring to piston.

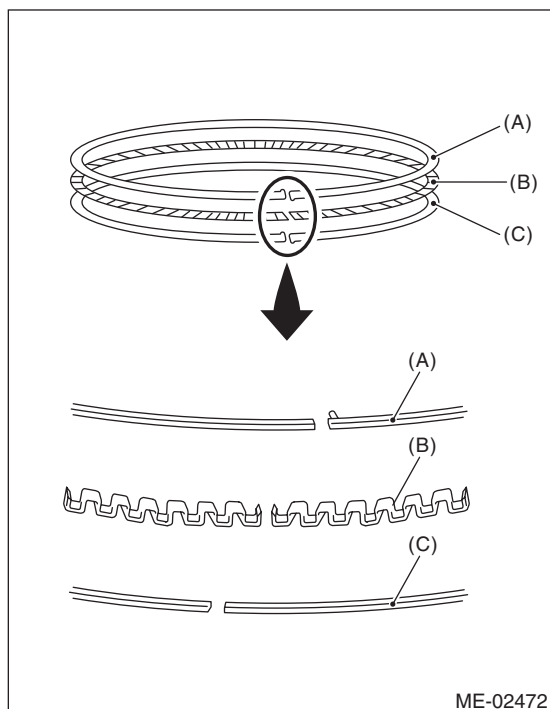

- (A) Upper rail
- (B) Expander
- (C) Lower rail

2) Clean the piston ring groove and piston ring.  
3) Squarely place the piston ring and oil ring in cylinder, and measure the piston ring gap with a thickness gauge.

		mm (in)
		Standard
Piston ring gap	Top ring	0.20 — 0.35 (0.0079 — 0.0138)
	Second ring	0.37 — 0.52 (0.0144 — 0.0203)
	Oil ring rail	0.20 — 0.50 (0.0079 — 0.0197)

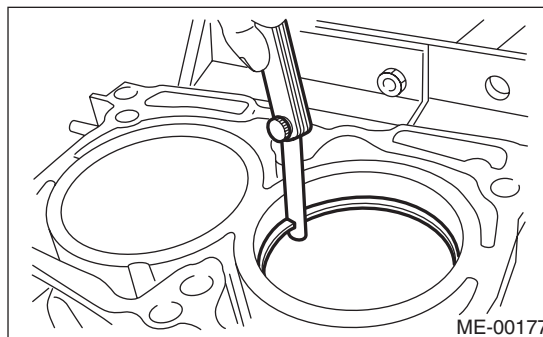

4) Measure the clearance between piston ring and piston ring groove with a thickness gauge.

		mm (in)
		Standard
Clearance between piston ring and piston ring groove	Top ring	0.040 — 0.080 (0.0016 — 0.0031)
	Second ring	0.030 — 0.070 (0.0012 — 0.0028)

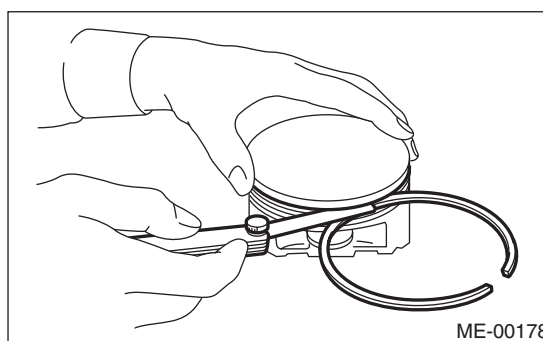

# Cylinder Block

MECHANICAL

## 5. CONNECTING ROD

- 1) Replace the connecting rod, if the large or small end thrust surface is damaged.
- 2) Check for bend or twist using a connecting rod aligner. Replace the connecting rod if the bend or twist exceeds the limit.

**Limit of bend or twist per 100 mm (3.94 in) in length:**  
**0.10 mm (0.0039 in)**

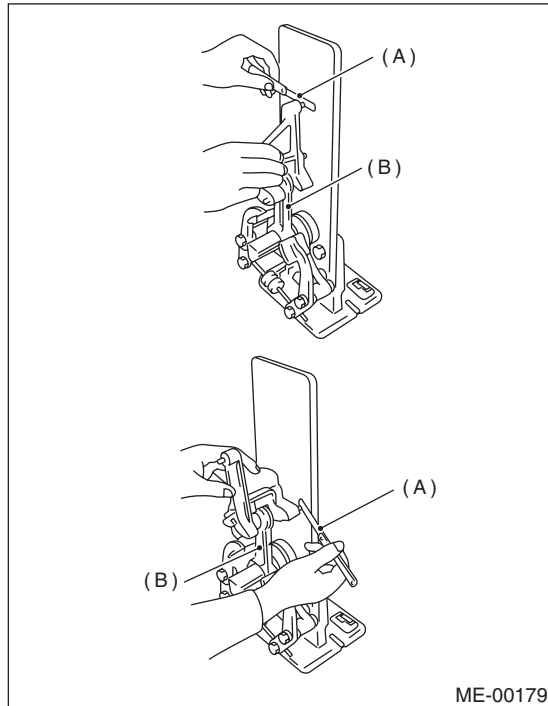

- (A) Thickness gauge  
 (B) Connecting rod

- 3) Install the connecting rod fitted with bearing to crankshaft and measure the side clearance (thrust clearance). Replace the connecting rod if the side clearance exceeds the specified limit.

**Connecting rod side clearance:**  
**Standard:**  
**0.070 — 0.330 mm (0.0028 — 0.0130 in)**

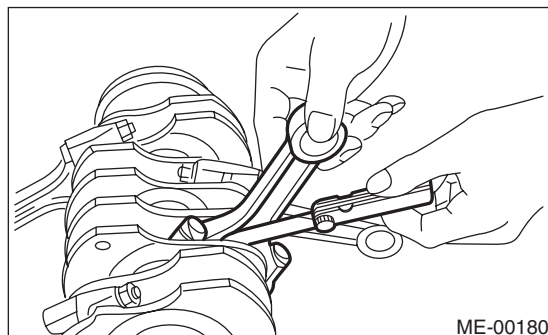

- 4) Inspect the connecting rod bearing for scar, peeling, seizure, melting, wear, etc.

- 5) Measure the oil clearance on each connecting rod bearing using plastigauge. If any oil clearance is not within the standard, replace the defective bearing with a new part of standard size or under-size as necessary. (See the table below.)

**Connecting rod oil clearance:**

**Standard:**

**0.016 — 0.044 mm (0.00063 — 0.0017 in)**

Unit: mm (in)		
Bearing	Bearing size (Thickness at center)	Outer diameter of crank pin
Standard	1.492 — 1.501 (0.0587 — 0.0591)	51.984 — 52.000 (2.0466 — 2.0472)
0.03 (0.0012) Undersize	1.510 — 1.513 (0.0594 — 0.0596)	51.954 — 51.970 (2.0454 — 2.0461)
0.05 (0.0020) Undersize	1.520 — 1.523 (0.0598 — 0.0600)	51.934 — 51.950 (2.0446 — 2.0453)
0.25 (0.0098) Undersize	1.620 — 1.623 (0.0638 — 0.0639)	51.734 — 51.750 (2.0368 — 2.0374)

- 6) Inspect the bushing at connecting rod small end, and replace if worn or damaged. Also measure the piston pin clearance at connecting rod small end.

**Clearance between piston pin and bushing:**

**Standard:**

**0 — 0.022 mm (0 — 0.0009 in)**

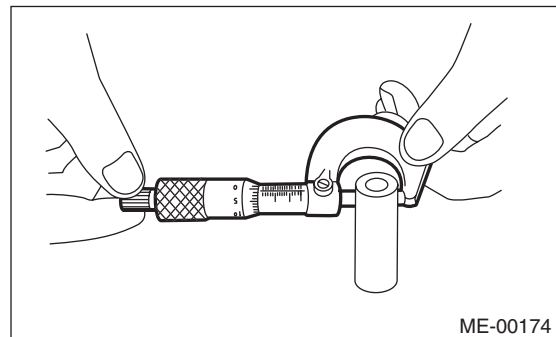
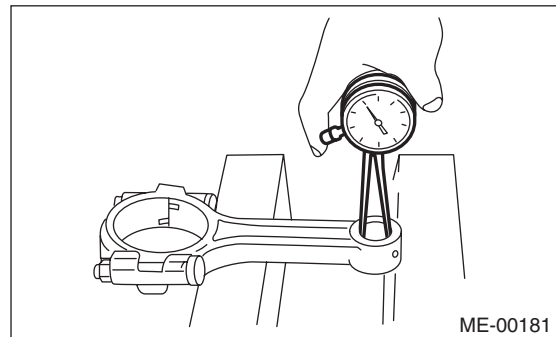

- 7) Replacement procedure is as follows.
- (1) Remove the bushing from connecting rod with ST and press.
  - (2) Press the bushing with ST after applying oil on the periphery of bushing.

ST 499037100 CONNECTING ROD BUSHING REMOVER & INSTALLER

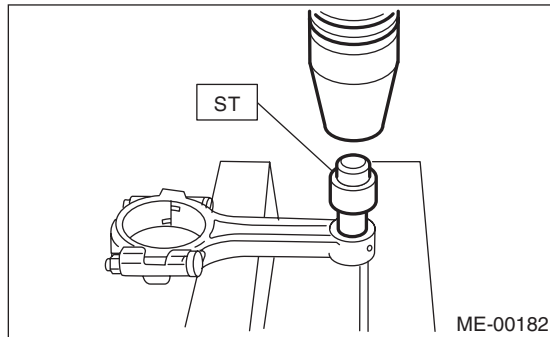

- (3) Make two 3 mm (0.12 in) holes in bushing. Ream the inside of bushing.
- (4) After completion of reaming, clean the bushing to remove chips.

## 6. CRANKSHAFT AND CRANKSHAFT BEARING

- 1) Clean the crankshaft completely, and check it for cracks using liquid penetrant tester. Replace if faulty.
- 2) Measure the bend of crankshaft. If it exceeds the limit, repair or replace it.

### NOTE:

If a suitable V-block is not available, install #1 and #5 crankshaft bearing on cylinder block, position the crankshaft on these bearings, and then measure the crankshaft bend using a dial gauge.

**Crankshaft bend limit:**  
**0.035 mm (0.0014 in)**

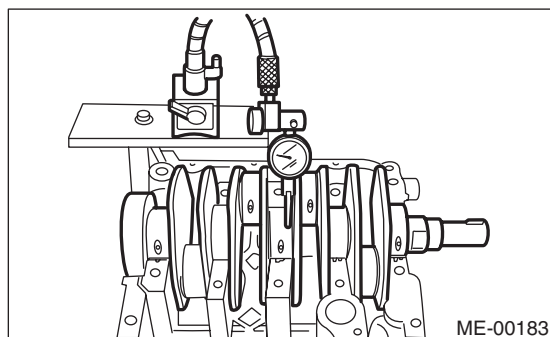

- 3) Inspect the crank journal and crank pin for wear. If they are not within the specification, replace the bearing with a suitable (undersize) one, and replace or readjust crankshaft as necessary. When grinding the crank journal or crank pin, finish them to the specified dimensions according to the undersize bearing to be used.

### Crank pin

**Out-of-roundness:**  
**0.003 mm (0.0001 in)**  
**Cylindricity:**  
**0.004 mm (0.0002 in)**  
**Grinding limit:**  
**To 51.750 mm (2.0374 in) dia.**

### Crank journal

**Out-of-roundness:**  
**0.005 mm (0.0002 in)**  
**Cylindricity:**  
**0.006 mm (0.0002 in)**  
**Grinding limit:**  
**To 59.750 mm (2.3524 in) dia.**

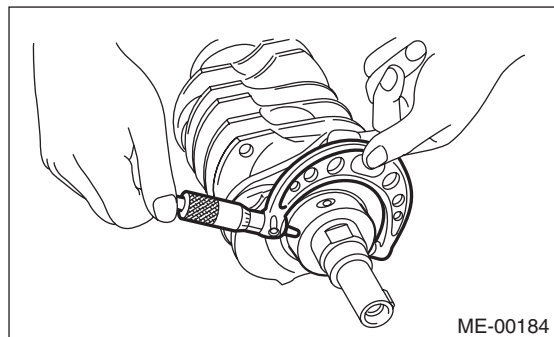

# Cylinder Block

MECHANICAL

		Unit: mm (in)		
		Crank journal outer diameter		Crank pin outer diameter
		#1, #3	#2, #4, #5	
Standard	Journal O.D.	59.992 — 60.008 (2.3619 — 2.3625)	59.992 — 60.008 (2.3619 — 2.3625)	51.984 — 52.000 (2.0466 — 2.0472)
	Bearing size (Thickness at center)	1.998 — 2.011 (0.0787 — 0.0792)	2.000 — 2.013 (0.0787 — 0.0793)	1.492 — 1.501 (0.0587 — 0.0591)
0.03 (0.0012) Undersize	Journal O.D.	59.962 — 59.978 (2.3607 — 2.3613)	59.962 — 59.978 (2.3607 — 2.3613)	51.954 — 51.970 (2.0454 — 2.0461)
	Bearing size (Thickness at center)	2.017 — 2.020 (0.0794 — 0.0795)	2.019 — 2.022 (0.0795 — 0.0796)	1.510 — 1.513 (0.0594 — 0.0596)
0.05 (0.0020) Undersize	Journal O.D.	59.942 — 59.958 (2.3599 — 2.3605)	59.942 — 59.958 (2.3599 — 2.3605)	51.934 — 51.950 (2.0446 — 2.0453)
	Bearing size (Thickness at center)	2.027 — 2.030 (0.0798 — 0.0799)	2.029 — 2.032 (0.0799 — 0.0800)	1.520 — 1.523 (0.0598 — 0.0600)
0.25 (0.0098) Undersize	Journal O.D.	59.742 — 59.758 (2.3520 — 2.3527)	59.742 — 59.758 (2.3520 — 2.3527)	51.734 — 51.750 (2.0368 — 2.0374)
	Bearing size (Thickness at center)	2.127 — 2.130 (0.0837 — 0.0839)	2.129 — 2.132 (0.0838 — 0.0839)	1.620 — 1.623 (0.0638 — 0.0639)

4) Measure the thrust clearance of crankshaft at center bearing. If clearance exceeds the standard, replace the bearing.

### **Crankshaft thrust clearance:**

#### **Standard:**

**0.030 — 0.115 mm (0.0012 — 0.0045 in)**

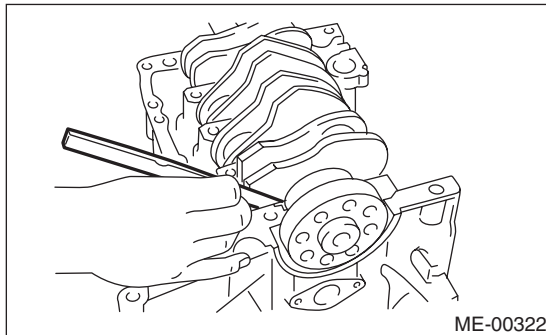

5) Inspect individual crankshaft bearings for signs of flaking, seizure, melting and wear.

6) Measure the oil clearance on each crankshaft bearing using plastigauge. If the measured value is out of standard, replace the defective bearing with an undersize one, and replace or recondition the crankshaft as necessary.

### **Crankshaft oil clearance:**

#### **Standard:**

**0.010 — 0.030 mm (0.0004 — 0.0012 in)**