

1. PREPARATION FOR THE INSPECTION MODE

- 1) Check battery voltage is more than 12 V and fuel remains half [20 — 40 ℓ (5.3 — 10.6 US gal, 4.4 — 8.8 Imp gal)].
- 2) Lift-up the vehicle using a garage jack and place it on rigid racks, or drive the vehicle onto free rollers.

WARNING:

- Before raising the vehicle, ensure parking brakes are applied.
- Do not use a pantograph jack in place of a rigid rack.
- Secure a rope or wire to the front or rear towing hooks to prevent the lateral runout of front wheels.
- Do not abruptly depress/release clutch pedal or accelerator pedal during works even when the engine is operating at low speeds since this may cause vehicle to jump off free rollers.
- In order to prevent the vehicle from slipping due to vibration, do not place any wooden blocks or similar items between the rigid racks and vehicle.
- Since the rear wheels will also rotate, do not place anything near them. Also, make sure that nobody goes in front of the vehicle.

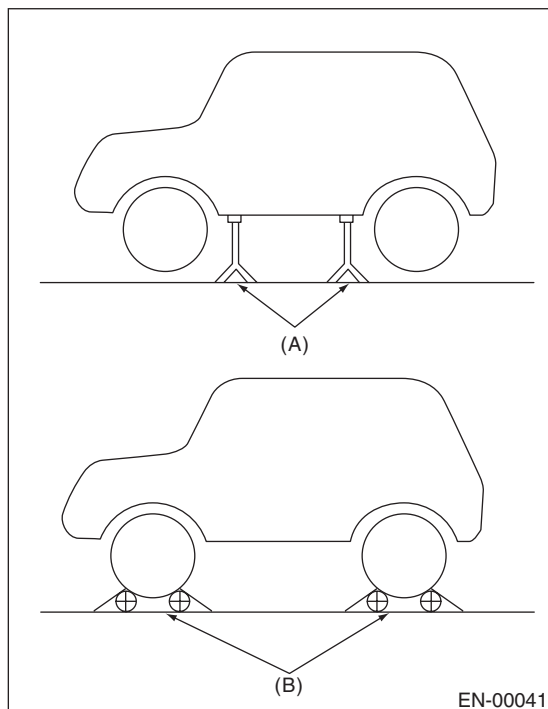

- (A) Rigid racks
(B) Free rollers

2. SUBARU SELECT MONITOR

- 1) After clearing the memory, check for any remaining unresolved trouble data. <Ref. to EN(H4DOTC)(diag)-42, Clear Memory Mode.>
- 2) Warm-up the engine.
- 3) Prepare the Subaru Select Monitor kit. <Ref. to EN(H4DOTC)(diag)-7, PREPARATION TOOL, General Description.>



- 4) Connect the diagnosis cable to the Subaru Select Monitor.
- 5) Insert the cartridge to the Subaru Select Monitor. <Ref. to EN(H4DOTC)(diag)-7, PREPARATION TOOL, General Description.>

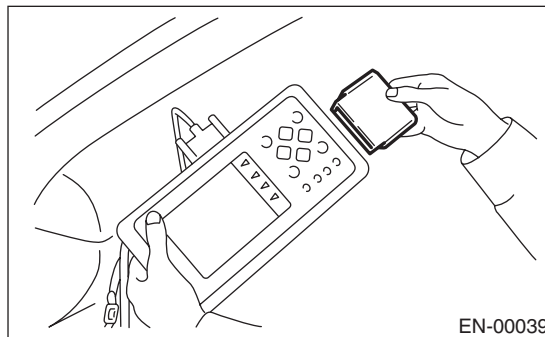

- 6) Connect the test mode connector (A) located under the glove box.

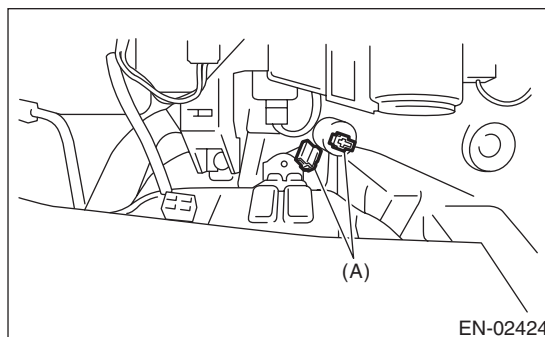

- (A) Test mode connector

Inspection Mode

ENGINE (DIAGNOSTICS)

7) Connect the Subaru Select Monitor to data link connector located in the lower portion of the instrument panel (on the driver's side).

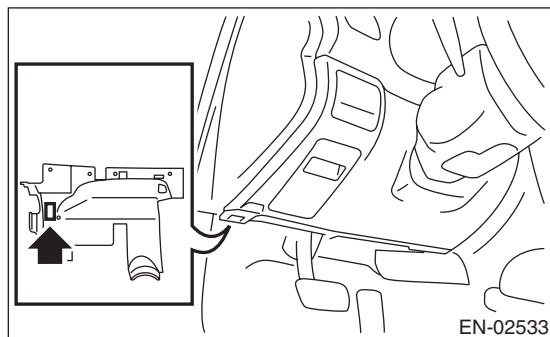

CAUTION:

Do not connect any scan tools except the Subaru Select Monitor or the general scan tool.

8) Turn the ignition switch to ON (engine OFF) and Subaru Select Monitor switch to ON.

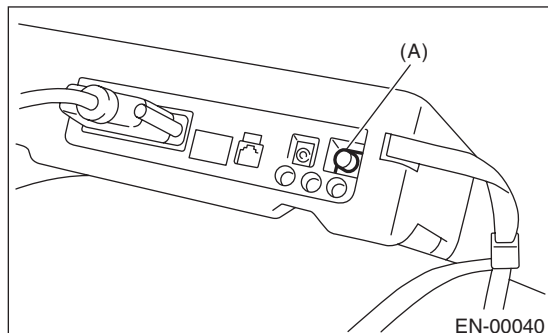

(A) Power switch

9) On the «Main Menu» display screen, select {Each System Check} and press the [YES] key.

10) On the «System Selection Menu» display screen, select {Engine Control System} and press the [YES] key.

11) Press the [YES] key after the information of engine type has been displayed.

12) On the «Engine Diagnosis» display screen, select {D Check} and press the [YES] key.

13) When the "Perform Inspection (Dealer Check Mode)" is shown on the screen, press the [YES] key.

14) Perform subsequent procedures as instructed on the display screen.

- If trouble still remains in the memory, the corresponding DTC appears on the display screen.

NOTE:

- For detailed operation procedure, refer to the "SUBARU SELECT MONITOR OPERATION MANUAL".
- For details concerning DTC, refer to "List of Diagnostic Trouble Code (DTC)".
<Ref. to EN(H4DOTC)(diag)-68, List of Diagnostic Trouble Code (DTC).>
- Release the parking brake.
- The speed difference between front and rear wheels may light the ABS warning light, but this does not indicate a malfunction. When engine control diagnosis is finished, perform the ABS memory clearance procedure of the self-diagnosis system. <Ref. to ABS(diag)-25, Clear Memory Mode.>

3. GENERAL SCAN TOOL

1) After clearing the memory, check for any remaining unresolved trouble data.

<Ref. to EN(H4DOTC)(diag)-42, Clear Memory Mode.>

2) Warm-up the engine.

3) Connect the test mode connector (A) located under the glove box.

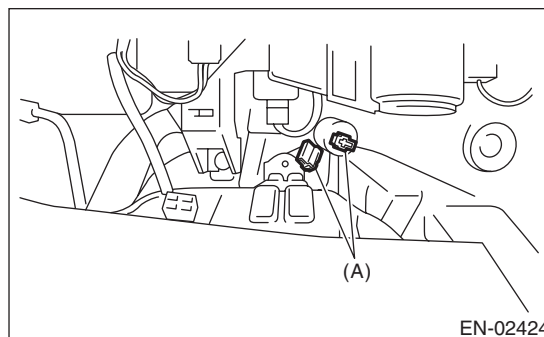

4) Connect the general scan tool to data link connector located in the lower portion of the instrument panel (on the driver's side).

CAUTION:

Do not connect any scan tools except the Subaru Select Monitor or the general scan tool.

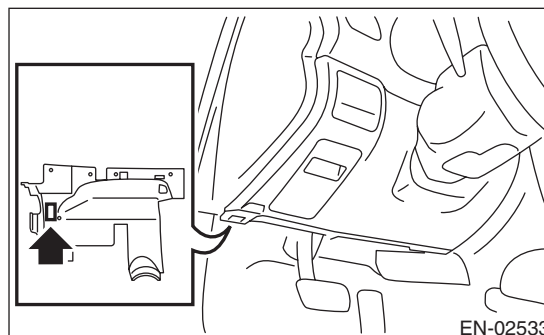

5) Start the engine.

NOTE:

- Make sure the select lever is placed in the “P” position before starting. (AT model)
- Depress the clutch pedal when starting engine. (MT model)

6) Using the select lever or shift lever, turn the “P” position switch and “N” position switch on.

7) Depress the brake pedal to turn the brake switch ON. (AT model)

8) Keep the engine speed in 2,500 — 3,000 rpm range for 40 seconds.

9) Place the selector lever or shift lever in D range (AT model) or 1st gear (MT model) and drive the vehicle at 5 to 10 km/h (3 to 6 MPH).

NOTE:

- For AWD model, release the parking brake.
- The speed difference between front and rear wheels may light the ABS warning light, but this indicates no malfunctions. When engine control diagnosis is finished, perform the ABS memory clearance procedure of the self-diagnosis system. <Ref. to ABS(diag)-25, Clear Memory Mode.>

10) Using the general scan tool, check for DTC and record the result(s).

NOTE:

- For detailed operation procedures, refer to the “General Scan Tool Instruction Manual”.
 - For details concerning DTC, refer to “List of Diagnostic Trouble Code (DTC)”.
- <Ref. to EN(H4DOTC)(diag)-68, List of Diagnostic Trouble Code (DTC).>