

## 4. Joint Pipe

### A: REMOVAL

- 1) Remove the collector cover.
- 2) Disconnect the ground cable from battery.

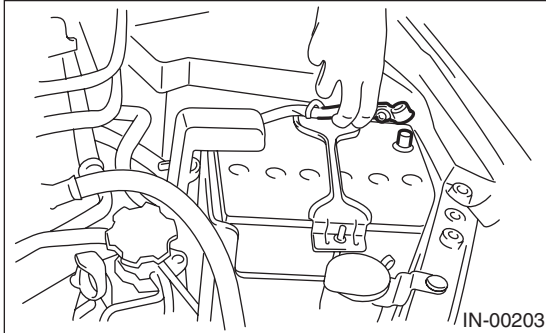

- 3) Disconnect the exhaust temperature sensor connector.

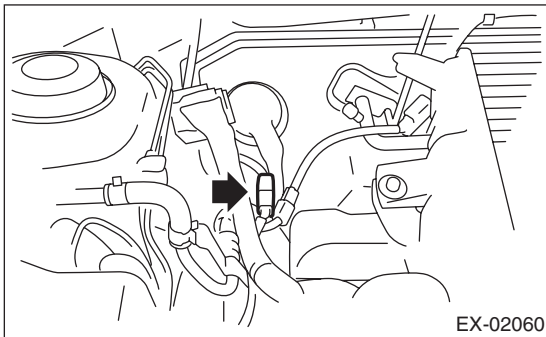

- 4) Remove the front oxygen (A/F) sensor. <Ref. to FU(H4DOTC)-34, REMOVAL, Front Oxygen (A/F) Sensor.>
- 5) Remove the under cover.
- 6) Remove the exhaust manifold lower cover (RH).

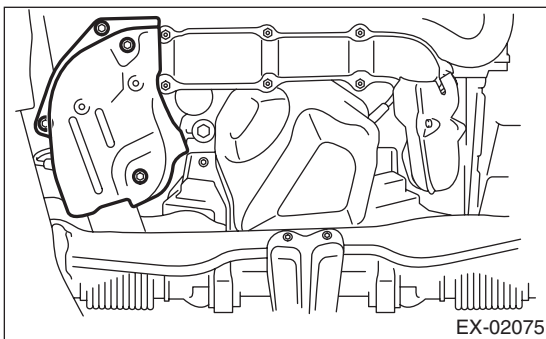

- 7) Remove the nuts which hold the front exhaust manifold to joint pipe.

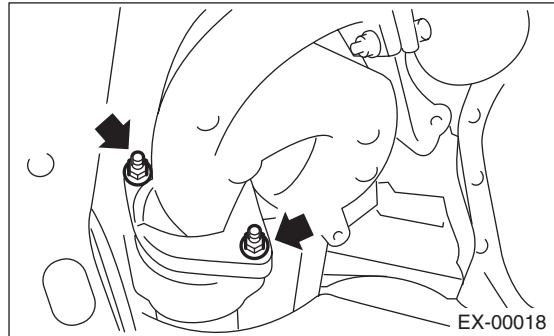

- 8) Remove the center exhaust pipe. <Ref. to EX(H4DOTC)-8, REMOVAL, Center Exhaust Pipe.>
- 9) Remove the turbocharger. <Ref. to IN(H4DOTC)-13, REMOVAL, Turbocharger.>
- 10) Take off the joint pipe in the upward direction.

### B: INSTALLATION

Install in the reverse order of removal.

#### Tightening torque:

**T: 35 N·m (3.6 kgf-m, 26.0 ft-lb)**

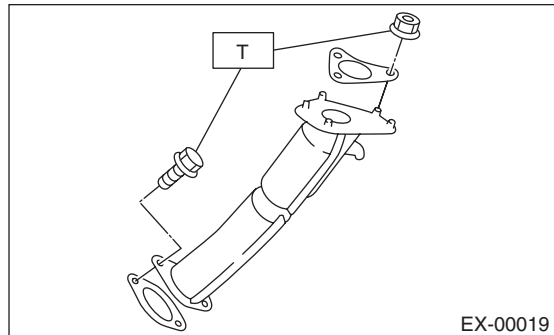

### C: INSPECTION

- 1) Check the connections and welds for exhaust leaks.
- 2) Make sure there are no holes or rusting.