

# Fuel Injector

## FUEL INJECTION (FUEL SYSTEMS)

### 11. Fuel Injector

#### A: REMOVAL

##### 1. RH SIDE

- 1) Release the fuel pressure.  
<Ref. to FU(H4DOTC)-43, RELEASING OF FUEL PRESSURE, PROCEDURE, Fuel.>
- 2) Open the fuel filler flap lid, and remove the fuel filler cap.
- 3) Remove the collector cover.
- 4) Disconnect the ground cable from battery.

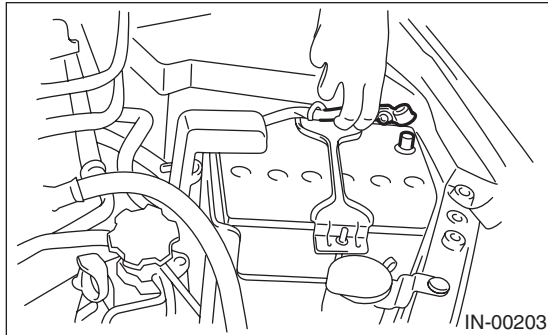

- 5) Remove the coolant filler tank. <Ref. to CO(H4DOTC)-31, REMOVAL, Coolant Filler Tank.>
- 6) Disconnect the connector from fuel injector.
- 7) Remove the screw, then remove the fuel injector.

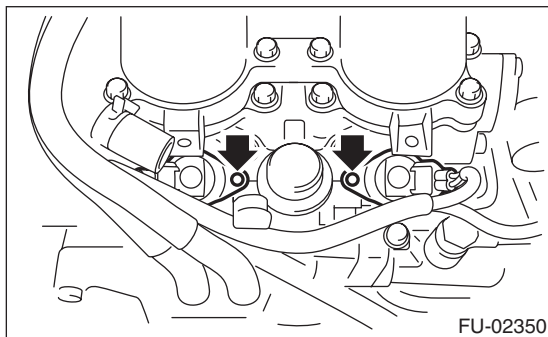

##### 2. LH SIDE

- 1) Release the fuel pressure.  
<Ref. to FU(H4DOTC)-43, RELEASING OF FUEL PRESSURE, PROCEDURE, Fuel.>
- 2) Open the fuel filler flap lid, and remove the fuel filler cap.
- 3) Remove the collector cover.
- 4) Disconnect the ground cable from battery.

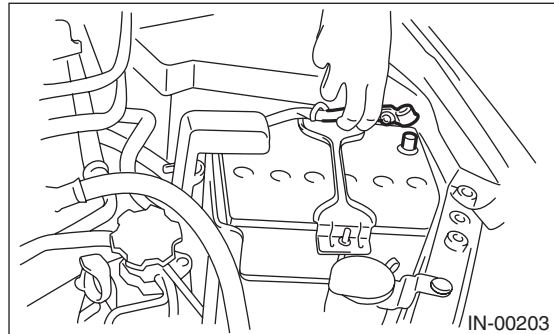

- 5) Disconnect the connector from fuel injector.
- 6) Remove the screw, then remove the fuel injector.

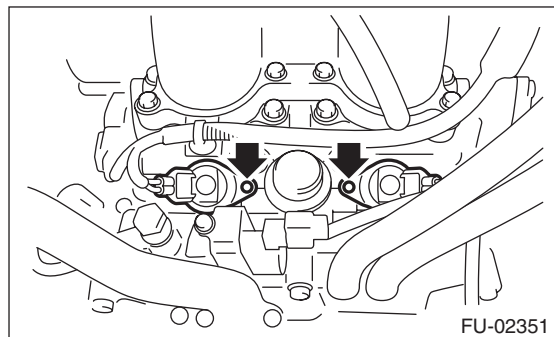

#### B: INSTALLATION

##### 1. RH SIDE

Install in the reverse order of removal.

NOTE:

Use new O-rings.

**Tightening torque:**

**3.5 N·m (0.36 kgf·m, 2.6 ft·lb)**

##### 2. LH SIDE

Install in the reverse order of removal.

NOTE:

Use new O-rings.

**Tightening torque:**

**3.5 N·m (0.36 kgf·m, 2.6 ft·lb)**