

Fuel Tank

FUEL INJECTION (FUEL SYSTEMS)

26. Fuel Tank

A: REMOVAL

WARNING:

- Place “NO FIRE” signs near the working area.
- Be careful not to spill fuel.

- 1) Set the vehicle on a lift.
- 2) Release the fuel pressure. <Ref. to FU(H4DOTC)-43, RELEASING OF FUEL PRESSURE, PROCEDURE, Fuel.>
- 3) Drain fuel from fuel tank. <Ref. to FU(H4DOTC)-43, DRAINING FUEL, PROCEDURE, Fuel.>
- 4) Remove the rear seat.
- 5) Remove the service hole cover of fuel pump.

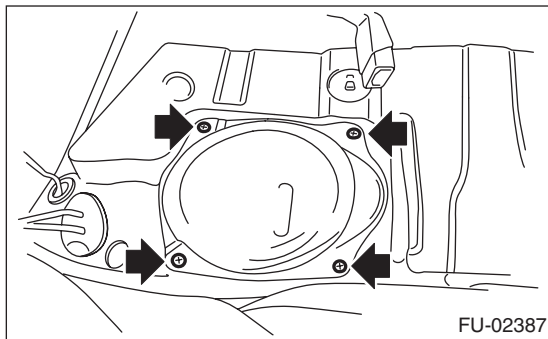

- 6) Disconnect the connector from fuel pump.

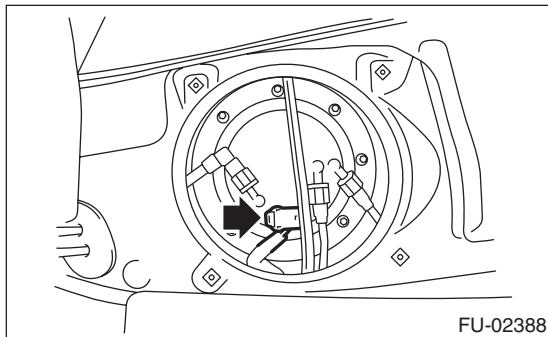

- 7) Remove the connector (A) and clip (B).

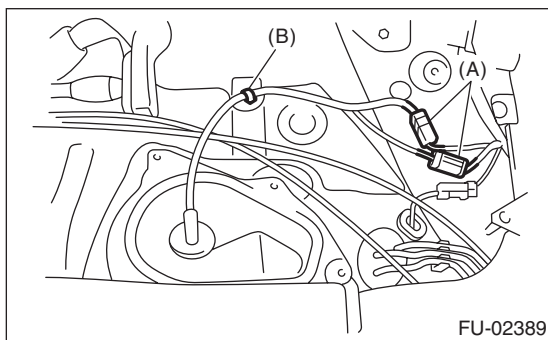

- 8) Remove the service hole cover of fuel sub level sensor.

- (1) Remove bolt (A).
- (2) Push the grommet (B) down and remove the service hole cover.

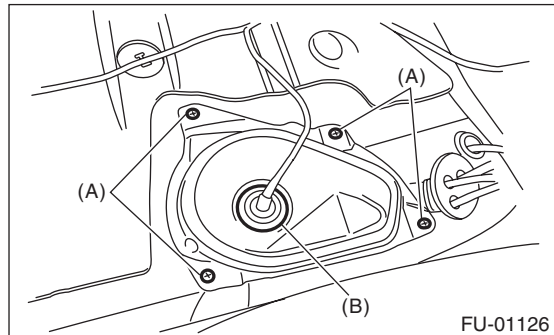

- 9) Disconnect connector (A) from fuel sub level sensor.

- 10) Disconnect the quick connector of fuel delivery (B) and return hose (C). <Ref. to FU(H4DOTC)-60, REMOVAL, Fuel Delivery, Return and Evaporation Lines.>

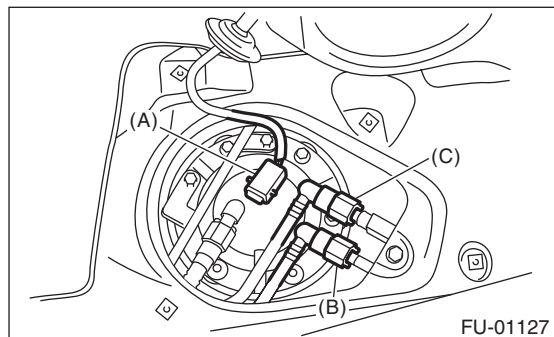

- 11) Remove the trunk room trim. (Sedan model) <Ref. to EI-68, REMOVAL, Trunk Room Trim.>

- 12) Remove the rear quarter trim. (Wagon model) <Ref. to EI-61, WAGON MODEL, REMOVAL, Rear Quarter Trim.>

- 13) Remove the pipe protector.

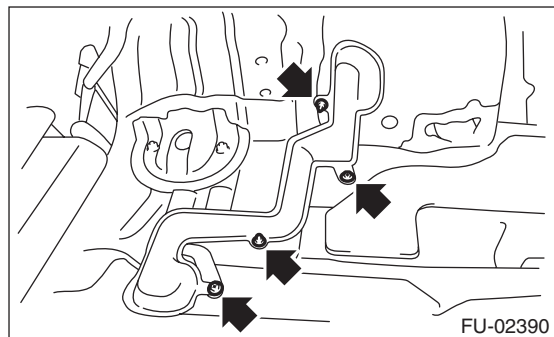

Fuel Tank

FUEL INJECTION (FUEL SYSTEMS)

14) Remove the grommet and disconnect the quick connector of the evaporation pipe. <Ref. to FU(H4DOTC)-60, REMOVAL, Fuel Delivery, Return and Evaporation Lines.>

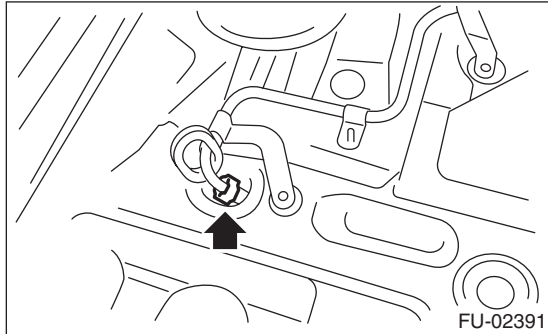

15) Remove the rear wheels.

16) Remove the bolts which secure the rear brake hose mounting bracket.

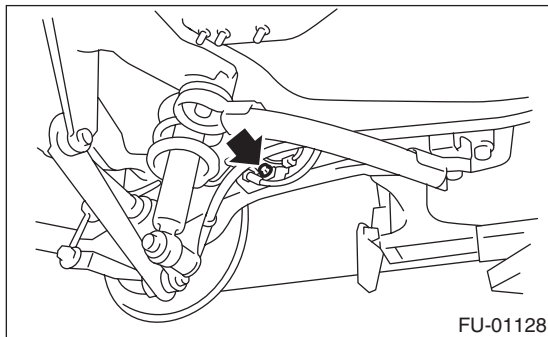

17) Remove the rear brake caliper and tie it to the body side of the vehicle.

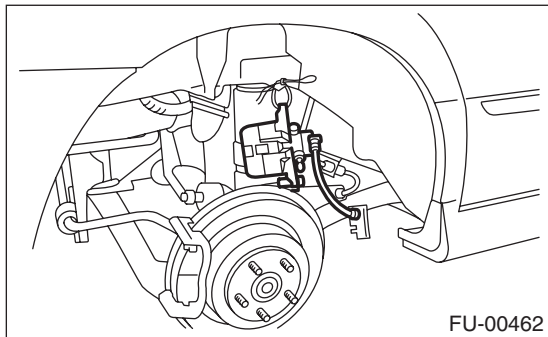

18) Remove the parking brake cable from parking brake assembly. <Ref. to PB-6, REMOVAL, Parking Brake Assembly (Rear Disc Brake).>

19) Lift-up the vehicle.

20) Remove the rear exhaust pipe.

<Ref. to EX(H4DOTC)-12, REMOVAL, Rear Exhaust Pipe.>

21) Remove the propeller shaft. <Ref. to DS-10, REMOVAL, Propeller Shaft.>

22) Remove the heat shield cover.

23) Disconnect the connector from the rear ABS wheel speed sensor.

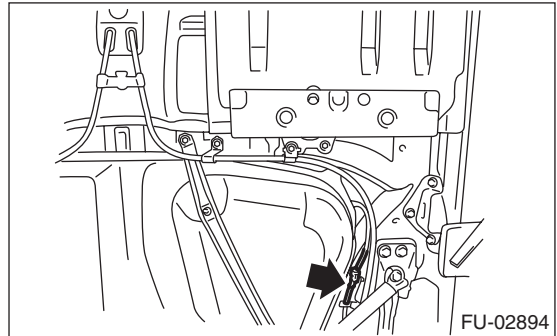

24) Remove the bolts securing the parking brake cable clamp.

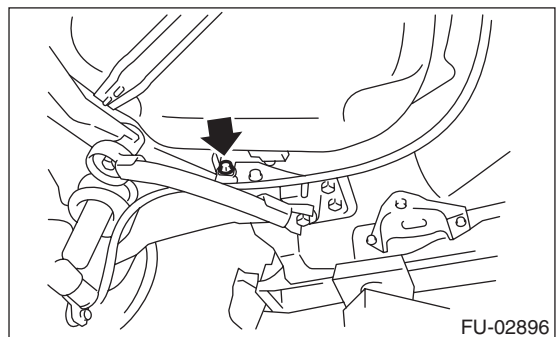
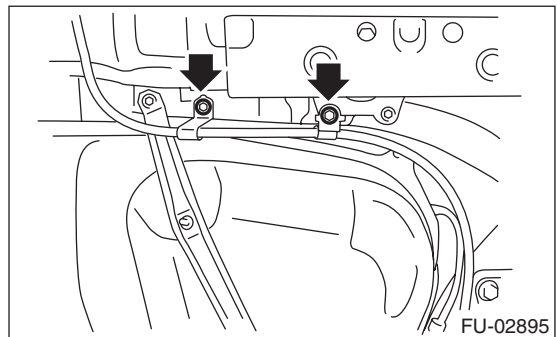

25) Remove the rear suspension assembly.

WARNING:

A helper is required to perform this work.

(1) Support the rear differential with the transmission jack.

(2) Remove the bolts which hold the rear shock absorber to the rear suspension arm.

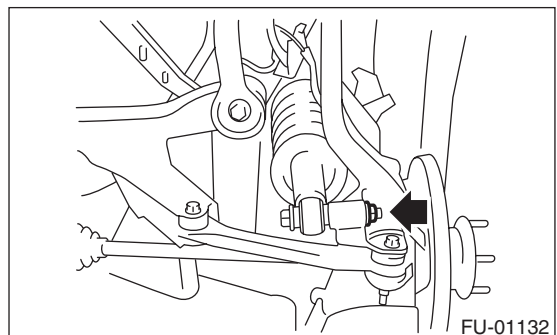

Fuel Tank

FUEL INJECTION (FUEL SYSTEMS)

(3) Remove the bolts which secure the rear suspension assembly to the body.

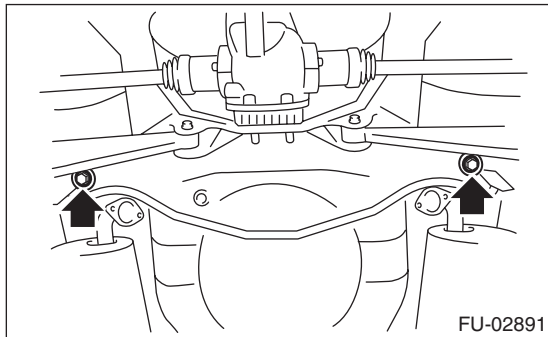
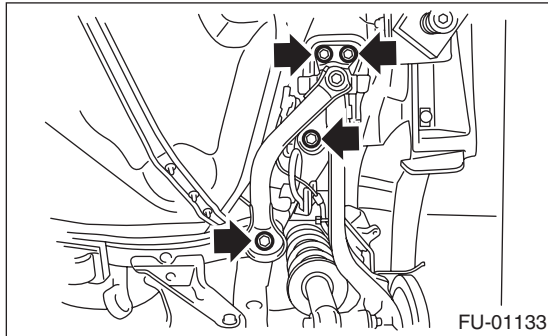

(4) Remove the rear suspension assembly.
26) Disconnect the connector.

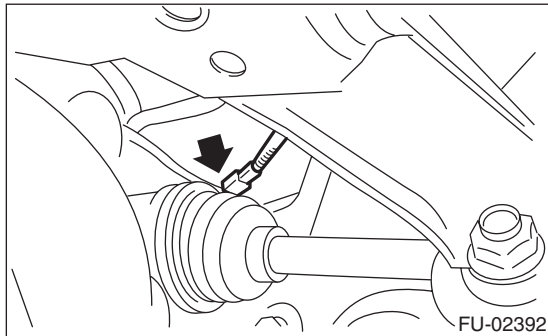

27) Disconnect the evaporation hose.

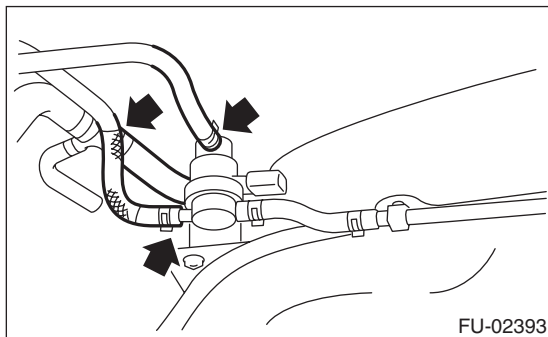

28) Disconnect the fuel filler hose (A) and evaporation hose (B).

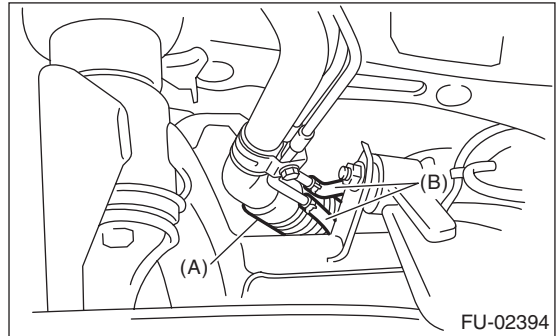

29) Support the fuel tank with a transmission jack, remove the bolts from the fuel tank band, and remove the fuel tank from the vehicle.

WARNING:

A helper is required to perform this work.

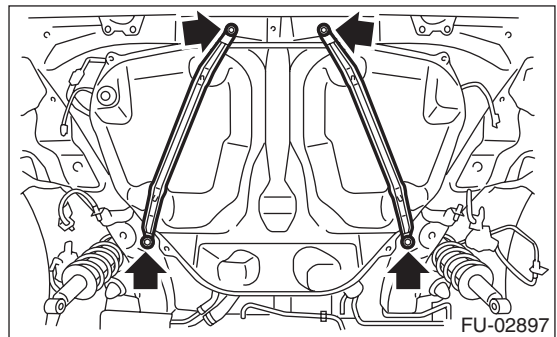

B: INSTALLATION

1) Support the fuel tank with a transmission jack, set the fuel tank in place, and temporarily tighten the bolts of the fuel tank band.

WARNING:

A helper is required to perform this work.

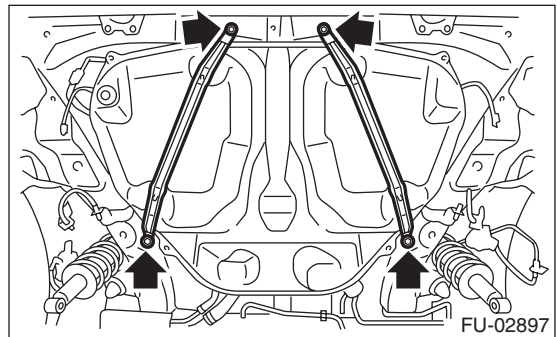

Fuel Tank

FUEL INJECTION (FUEL SYSTEMS)

2) Securely insert the fuel filler hose (A) and evaporation hose (B) to the specified position, then tighten the clamp.

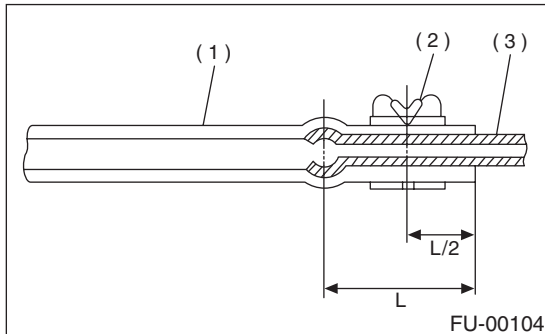
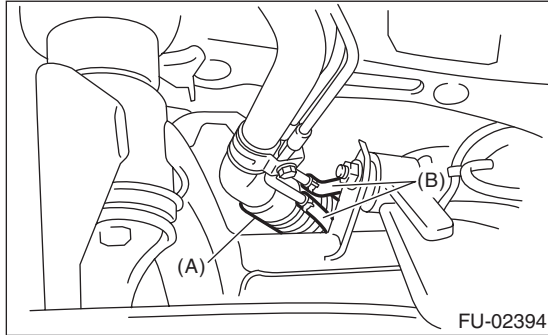

- (1) Hose
- (2) Clip or clamp
- (3) Pipe

3) Connect the evaporation hose.

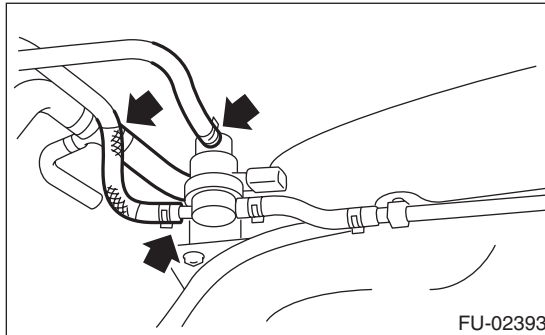

4) Tighten the fuel tank band bolts.

Tightening torque:
33 N·m (3.4 kgf-m, 25 ft-lb)

5) Connect the connector.

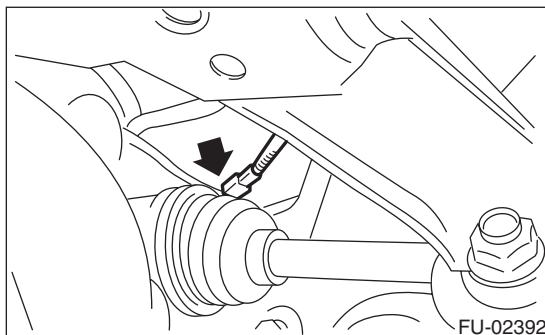

6) Install the rear suspension assembly.

CAUTION:

A helper is required to perform this work.

- (1) Support the rear differential with the transmission jack.
- (2) Support the rear suspension assembly, and tighten the bolts which secure the rear suspension assembly to the body.

Tightening torque:

T1: 125 N·m (12.7 kgf-m, 92.2 ft-lb)

T2: 175 N·m (17.8 kgf-m, 129 ft-lb)

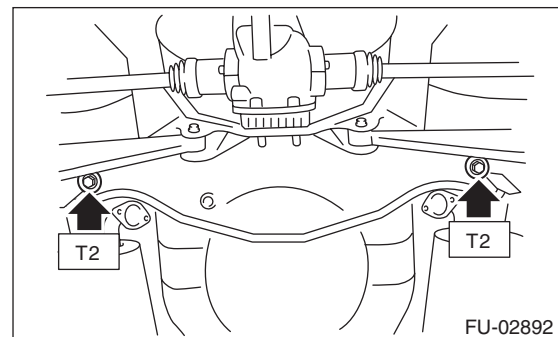
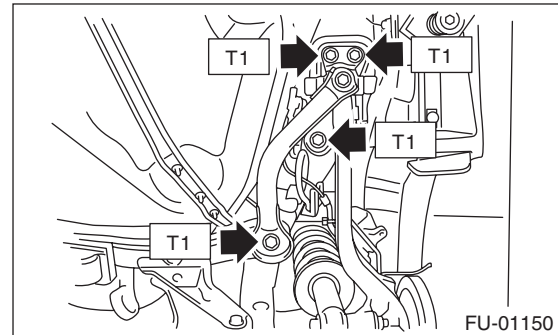

(3) Tighten the bolts which hold the rear shock absorber to the rear suspension arm. <Ref. to RS-10, INSTALLATION, Rear Arm.>

Tightening torque:

62 N·m (6.3 kgf-m, 46 ft-lb)

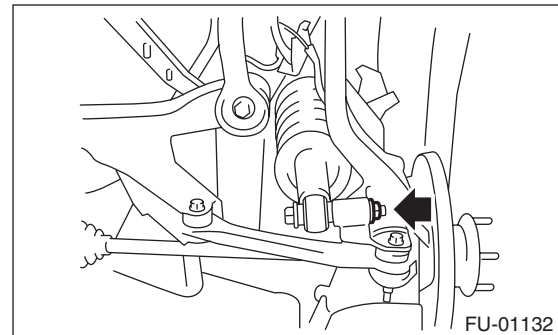

Fuel Tank

FUEL INJECTION (FUEL SYSTEMS)

7) Tighten the bolts holding the parking brake cable clamp.

Tightening torque:

18 N·m (1.8 kgf·m, 13.3 ft·lb)

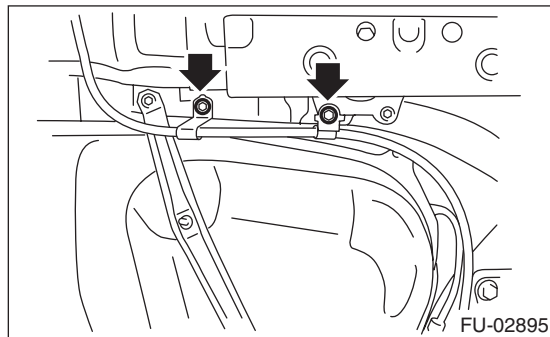

Tightening torque:

32 N·m (3.3 kgf·m, 23.9 ft·lb)

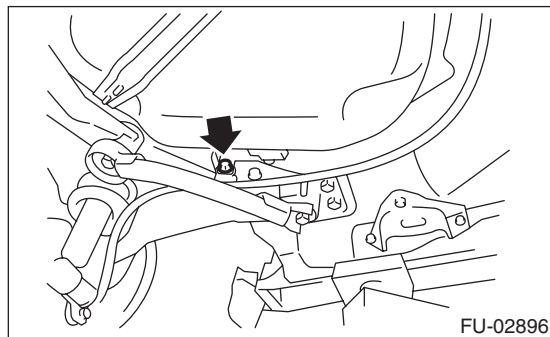

8) Connect the connector to the rear ABS wheel speed sensor.

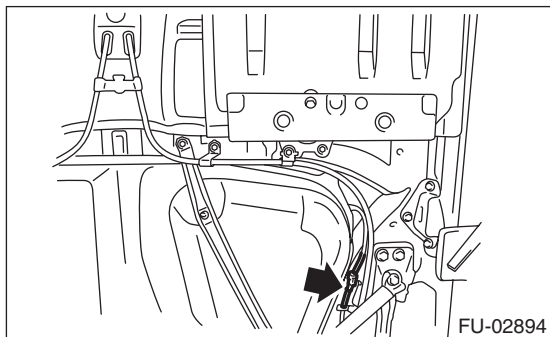

9) Install the heat shield cover.

10) Install the propeller shaft. <Ref. to DS-11, INSTALLATION, Propeller Shaft.>

11) Install the rear exhaust pipe. <Ref. to EX(H4DOTC)-12, INSTALLATION, Rear Exhaust Pipe.>

12) Lower the vehicle.

13) Connect the parking brake cable to the parking brake assembly. <Ref. to PB-7, INSTALLATION, Parking Brake Assembly (Rear Disc Brake).>

14) Install the rear brake caliper.

15) Tighten the bolts which secure the rear brake hose mounting bracket.

Tightening torque:

33 N·m (3.4 kgf·m, 25 ft·lb)

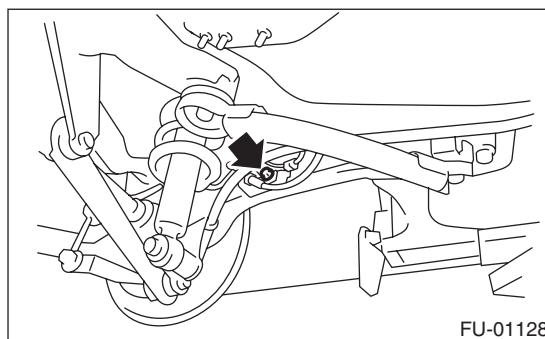

16) Install the rear wheels.

17) Lower the vehicle.

18) Connect the quick connector of the evaporation pipe. <Ref. to FU(H4DOTC)-61, INSTALLATION, Fuel Delivery, Return and Evaporation Lines.>

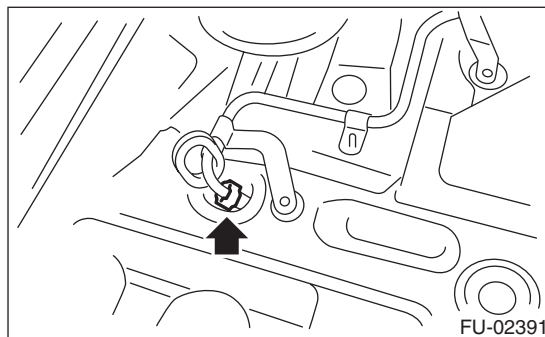

19) Install the pipe protector.

Tightening torque:

T1: 1.0 N·m (1.0 kgf·m, 0.7 ft·lb)

T2: 7.5 N·m (0.7 kgf·m, 5.5 ft·lb)

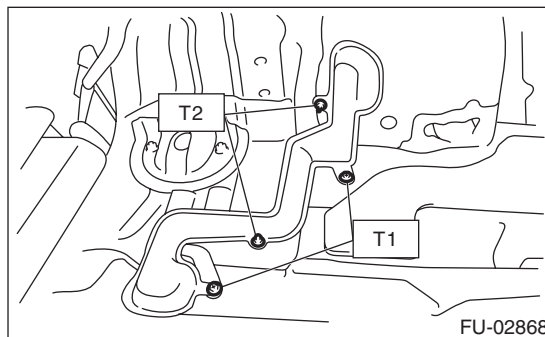

20) Install the trunk room trim. (Sedan model) <Ref. to EI-69, INSTALLATION, Trunk Room Trim.>

21) Install the rear quarter trim. (Wagon model) <Ref. to EI-62, INSTALLATION, Rear Quarter Trim.>

22) Connect connector (A) to the fuel sub level sensor.

23) Connect the quick connector of fuel delivery (B) and return hose (C). <Ref. to FU(H4DOTC)-61, INSTALLATION, Fuel Delivery, Return and Evaporation Lines.>

NOTE:

When connecting, be careful not to reverse the delivery side and return side.

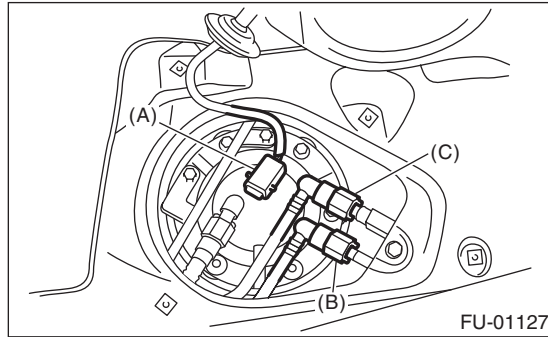

24) Install the service hole cover of fuel sub level sensor.

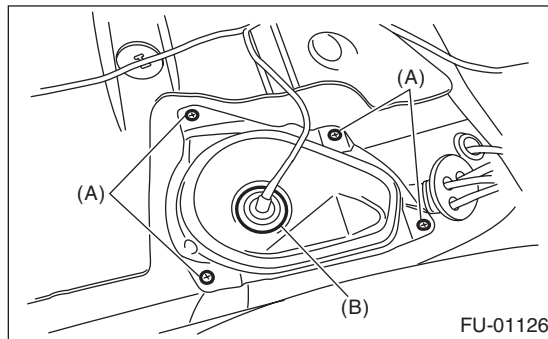

- (A) Bolt
- (B) Grommet

25) Connect connector (A), and install clip (B).

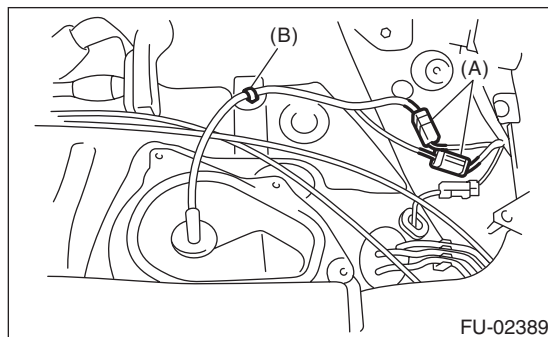

26) Connect the connector to the fuel pump.

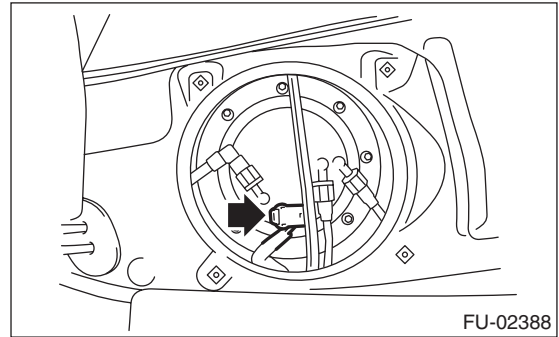

27) Install the service hole cover of fuel pump.

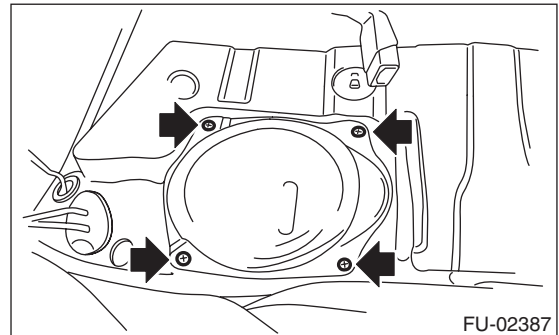

28) Install the rear seat.

29) Install the fuse of fuel pump to main fuse box.

C: INSPECTION

- 1) Check that the fuel tank does not have holes, cracks or is damaged in any other way.
- 2) Make sure that the fuel pipe and fuel hose are not cracked and that the connections are tight.