

Fuel Sub Level Sensor

FUEL INJECTION (FUEL SYSTEMS)

30. Fuel Sub Level Sensor

A: REMOVAL

WARNING:

- Place “NO FIRE” signs near the working area.
- Be careful not to spill fuel.

- 1) Drain fuel. <Ref. to FU(H4DOTC)-43, DRAINING FUEL, PROCEDURE, Fuel.>
- 2) Remove the rear seat.
- 3) Remove the service hole cover.
 - (1) Remove bolt (A).
 - (2) Push the grommet (B) down and remove the service hole cover.

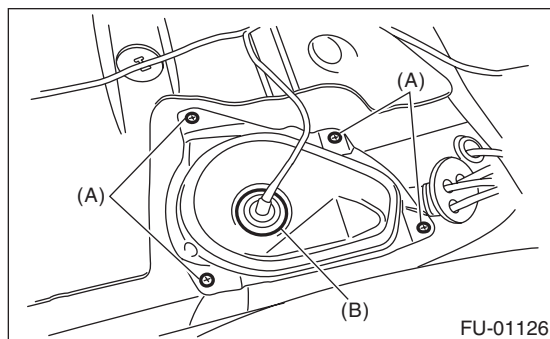

- 4) Disconnect the connector from fuel sub level sensor.

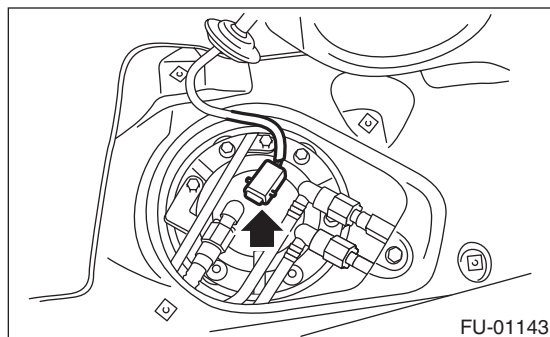

- 5) Disconnect the quick connector, then disconnect the fuel delivery hose, return hose and jet pump hose. <Ref. to FU(H4DOTC)-60, REMOVAL, Fuel Delivery, Return and Evaporation Lines.>

- 6) Remove the nuts and bolts which install fuel sub level sensor on fuel tank.

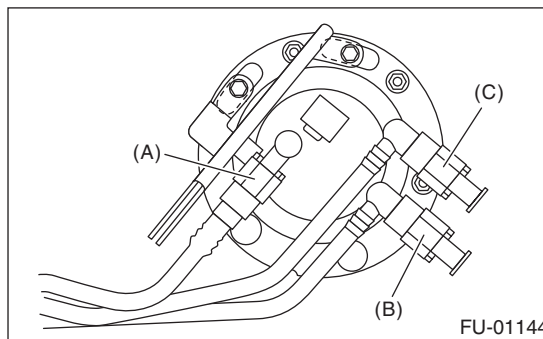

- (A) Jet pump hose
- (B) Delivery hose
- (C) Return hose

- 7) Remove the fuel sub level sensor.

B: INSTALLATION

Install in the reverse order of removal.

NOTE:

- Use a new gasket.
- Make sure the sealing portion is free from fuel or foreign matter before installation.
- Align the protrusion (A) of gasket with the position shown in the figure.
- Align the protrusion (B) of fuel sub level sensor with the cutout on the upper plate of fuel sub level sensor.
- Tighten the nuts and bolts to the specified torque in the order as shown in the figure.

Tightening torque:

4.4 N·m (0.45 kgf-m, 3.2 ft-lb)

