

# Intercooler

INTAKE (INDUCTION)

## 7. Intercooler

### A: REMOVAL

- 1) Remove the collector cover.
- 2) Loosen the clamp and remove the air by-pass pipe (A) from the air by-pass valve.
- 3) Loosen the clamp, and then remove the intake duct (B) from the intercooler.

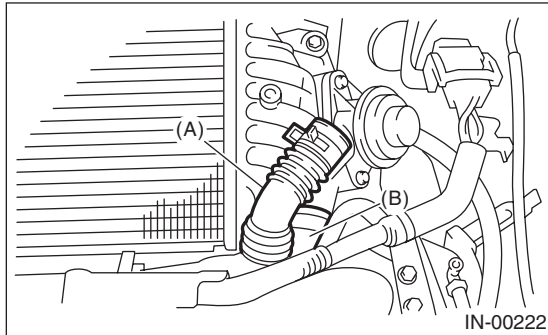

- 4) Remove the bolts which secure the intake duct to the turbocharger.
- 5) Remove the bolts which secure the intercooler to the bracket, and remove the intercooler.

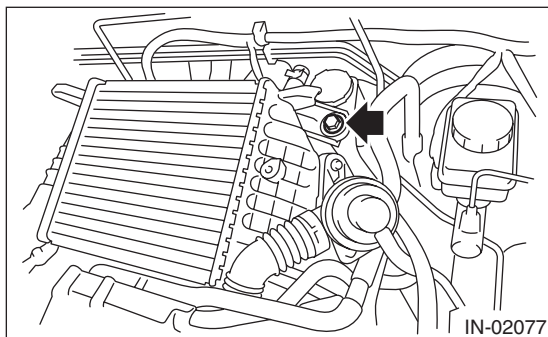
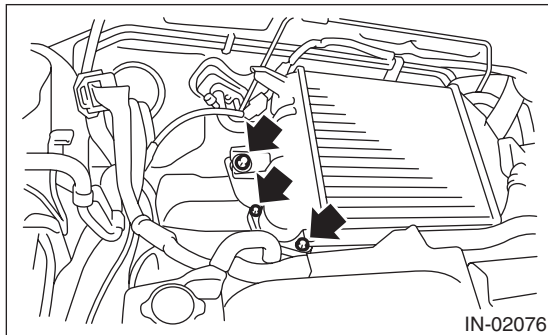

### B: INSTALLATION

Install in the reverse order of removal.

**Tightening torque:**

**16 N·m (1.6 kgf-m, 11.6 ft-lb)**

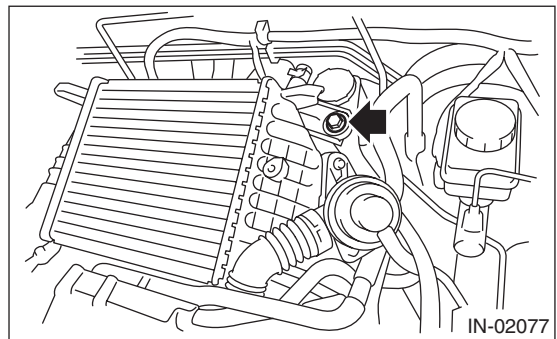
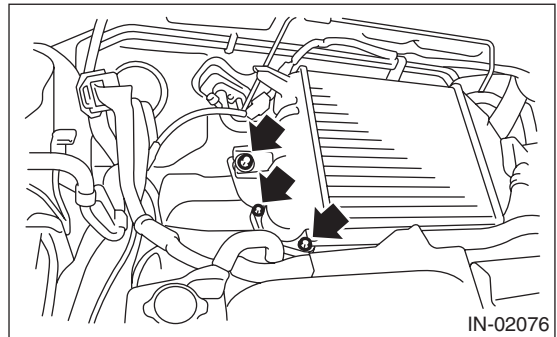

### C: DISASSEMBLY

- 1) Remove the intake duct from the intercooler.
- 2) Remove the air by-pass valve from intercooler.

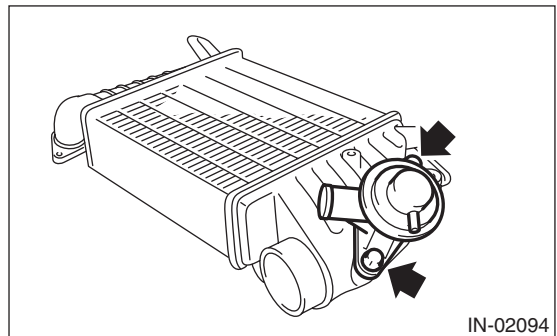

### D: ASSEMBLY

Assemble in the reverse order of disassembly.

**Tightening torque:**

**6.5 N·m (0.66 kgf-m, 4.8 ft-lb)**

