

8. Turbocharger

A: REMOVAL

- 1) Set the vehicle on a lift.
- 2) Remove the collector cover.
- 3) Disconnect the ground cable from battery.

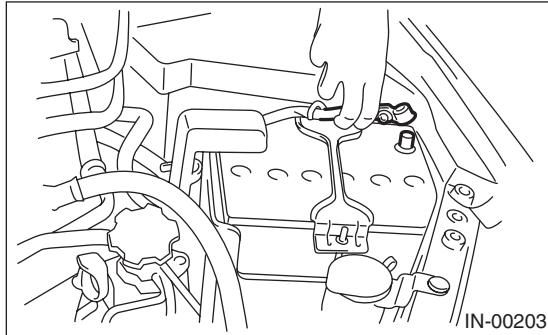

- 4) Remove the intercooler. <Ref. to IN(H4DOTC)-12, REMOVAL, Intercooler.>
- 5) Remove the intercooler bracket RH.
- 6) Remove the center exhaust pipe. <Ref. to EX(H4DOTC)-8, REMOVAL, Center Exhaust Pipe.>
- 7) Lower the vehicle.
- 8) Separate the turbocharger joint pipe from turbocharger.

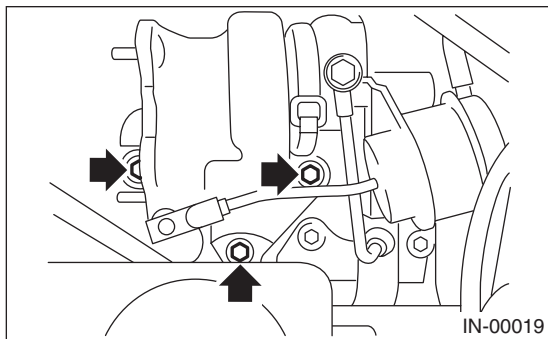

- 9) Disconnect the engine coolant hose which is connected to coolant filler tank.
- 10) Loosen the clamp which secures turbocharger to intake duct.

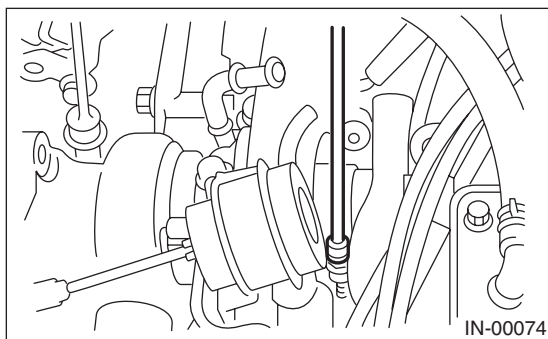

- 11) Remove the bolts which secure oil pipe bracket to turbocharger.

- 12) Remove the oil inlet pipe from the turbocharger.

CAUTION:

In order to prevent damaging the oil pipe on the cylinder head side, fix the section (a) shown in the figure when loosening the oil inlet pipe flare nut, and avoid the part from rotating together while loosening the nut.

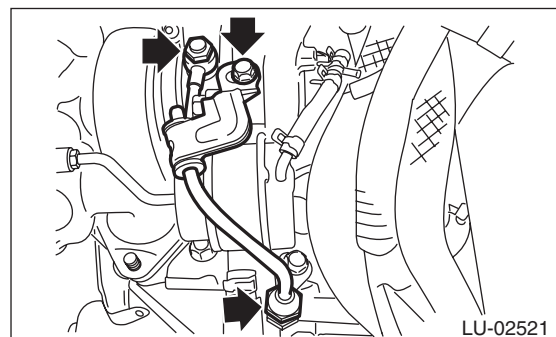
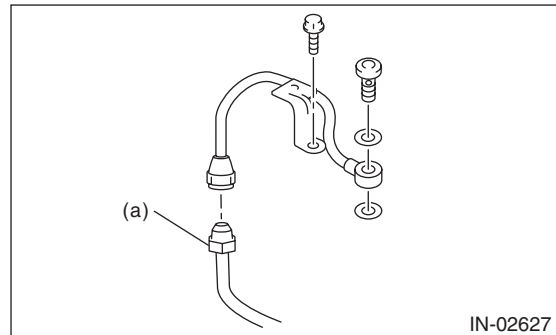

- 13) Remove the turbocharger bracket.

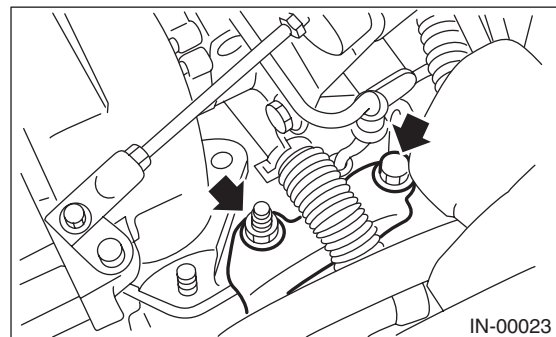

- 14) Disconnect the oil outlet hose from pipe.

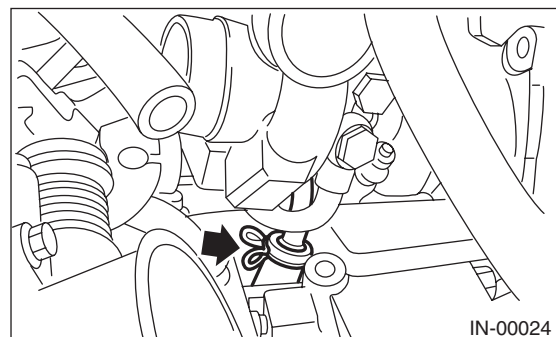

- 15) Take out the turbocharger from engine compartment.

Turbocharger

INTAKE (INDUCTION)

B: INSTALLATION

CAUTION:

When replacing the turbocharger, check the filter part of union screw for clogging. <Ref. to LU(H4DOTC)-22, INSPECTING UNION SCREW WITH FILTER, INSPECTION, Oil Pipe.>

1) Connect the oil outlet hose to outlet pipe.

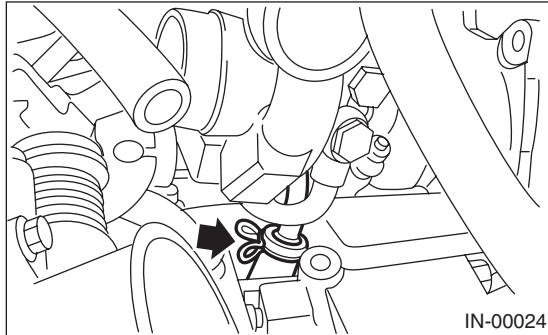

2) Install the turbocharger to intake duct.

Tightening torque:

3 N·m (0.3 kgf-m, 2.2 ft-lb)

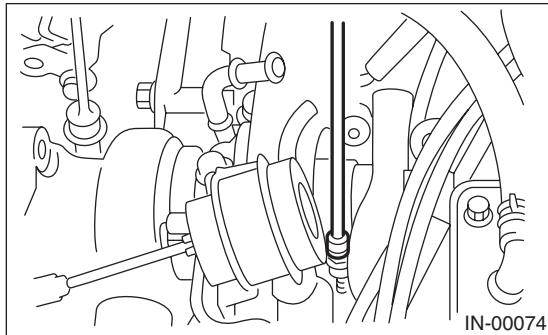

3) Temporarily tighten the bolts and flare nuts which secure the oil inlet pipe to the turbocharger.

NOTE:

Use a new gasket.

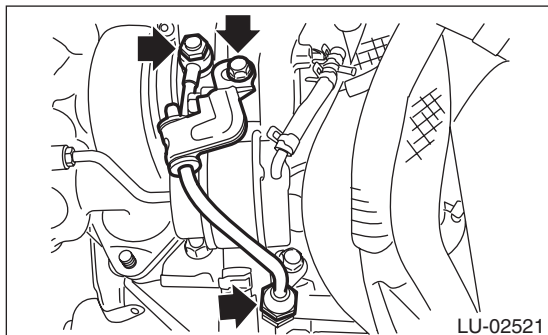

4) Tighten the union screws and flare nuts which secure the oil inlet pipe to the turbocharger.

CAUTION:

In order to prevent damaging the oil pipe on the cylinder head side, fix the section (a) shown in the figure when tightening the oil inlet pipe flare nut, and avoid the part from rotating together while tightening the nut.

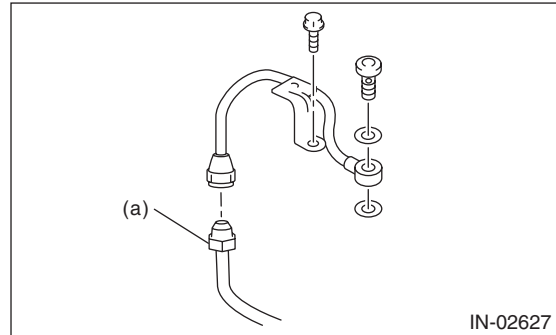

Tightening torque:

T1: 16 N·m (1.6 kgf-m, 11.8 ft-lb)

T2: 20 N·m (2.0 kgf-m, 14.8 ft-lb)

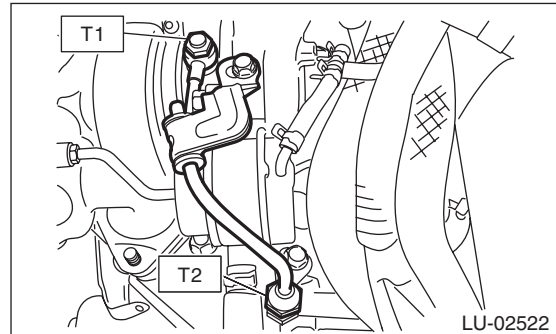

5) Tighten the bolts which hold the oil inlet pipe stay to the turbocharger.

Tightening torque:

5 N·m (0.5 kgf-m, 3.7 ft-lb)

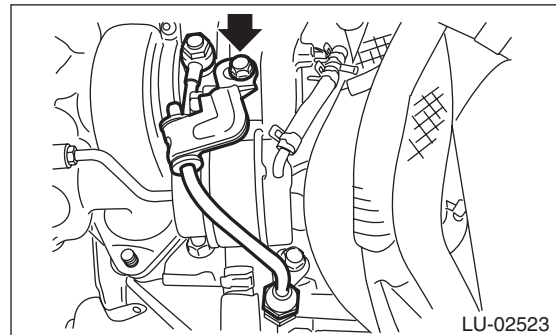

6) Install the joint pipe to turbocharger.

NOTE:

Replace the gasket with a new part.

Tightening torque:

30 N-m (3.1 kgf-m, 22.4 ft-lb)

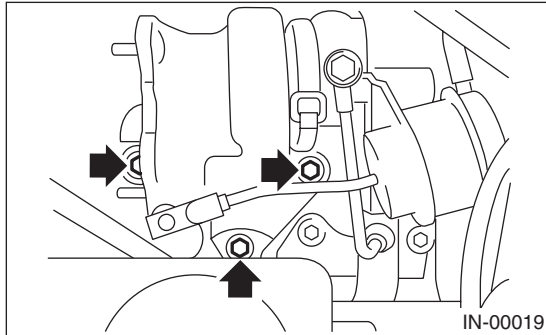

7) Install the turbocharger bracket.

Tightening torque:

33 N-m (3.4 kgf-m, 24.6 ft-lb)

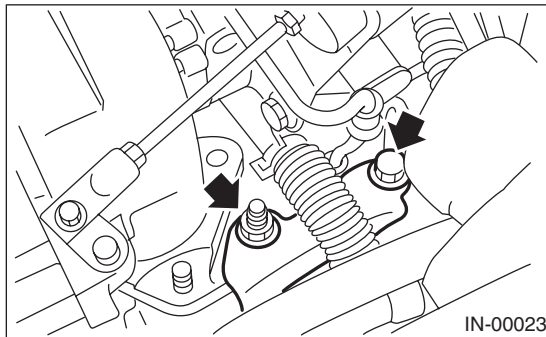

8) Connect the engine coolant hose which is connected to the coolant filler tank.

9) Lift-up the vehicle.

10) Install the center exhaust pipe. <Ref. to EX(H4DOTC)-9, INSTALLATION, Center Exhaust Pipe.>

11) Install the intercooler bracket RH.

12) Install the intercooler. <Ref. to IN(H4DOTC)-12, INSTALLATION, Intercooler.>

13) Install the collector cover.