

## 4. Oil Pump

### A: REMOVAL

- 1) Remove the collector cover.
- 2) Disconnect the ground cable from battery.

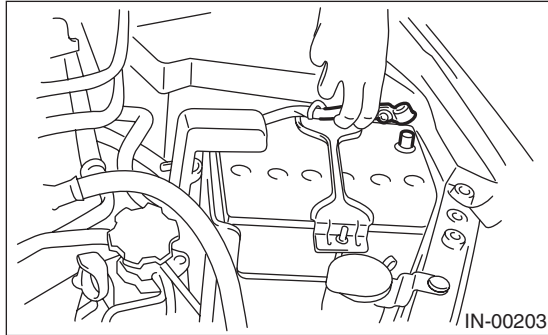

- 3) Lift up the vehicle.
- 4) Remove the under cover.
- 5) Remove the bolts which install water pipe of oil cooler to oil pump.

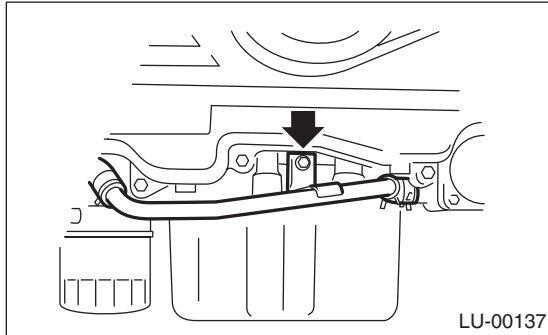

- 6) Remove the water pipe and hoses between oil cooler and water pump.

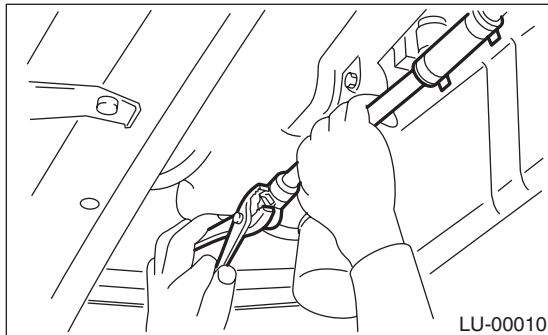

- 7) Lower the vehicle.
- 8) Remove the radiator. <Ref. to CO(H4DOTC)-19, REMOVAL, Radiator.>
- 9) Remove the V-belts. <Ref. to ME(H4DOTC)-36, REMOVAL, V-belt.>

- 10) Remove the rear side V-belt tensioner.

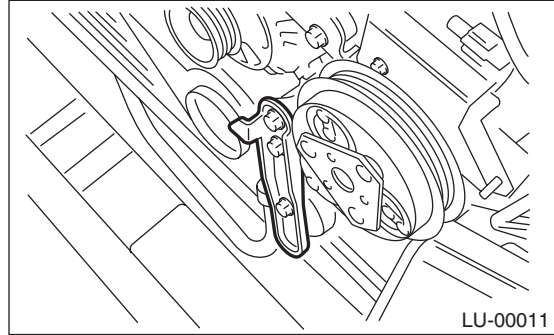

- 11) Remove the crankshaft position sensor.

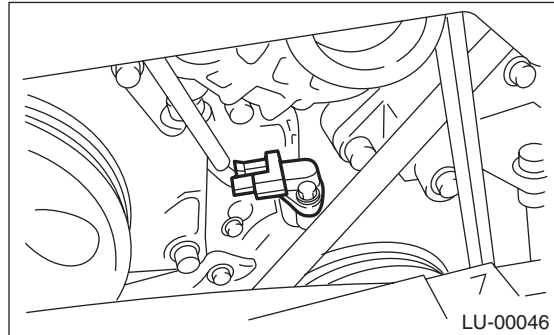

- 12) Remove the crank pulley using ST. <Ref. to ME(H4DOTC)-39, REMOVAL, Crank Pulley.>

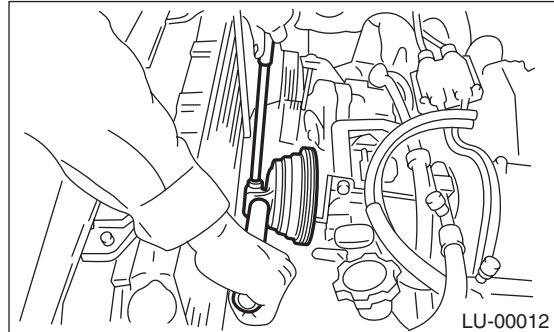

- 13) Remove the water pump. <Ref. to CO(H4DOTC)-15, REMOVAL, Water Pump.>

- 14) Remove the timing belt guide.

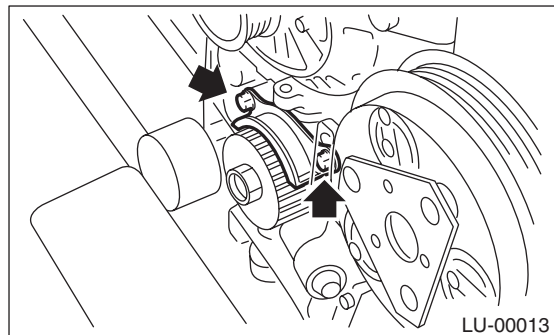

# Oil Pump

## LUBRICATION

15) Remove the crank sprocket.

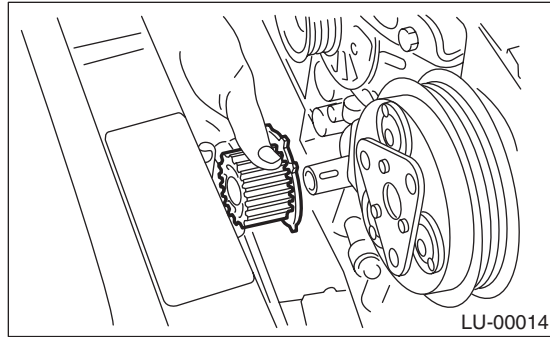

16) Remove the bolts which install oil pump onto cylinder block.

### NOTE:

When disassembling and checking the oil pump, loosen the relief valve plug before removing the oil pump.

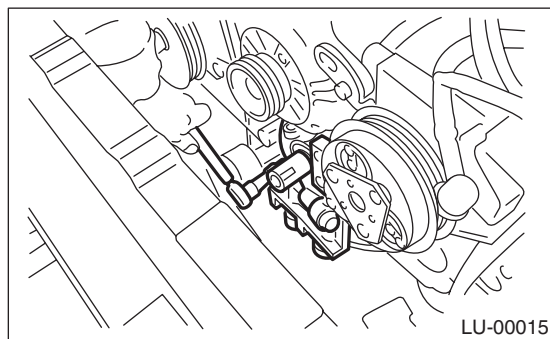

17) Remove the oil pump by using flat tip screwdriver.

### CAUTION:

Be careful not to scratch mating surfaces of cylinder block and oil pump.

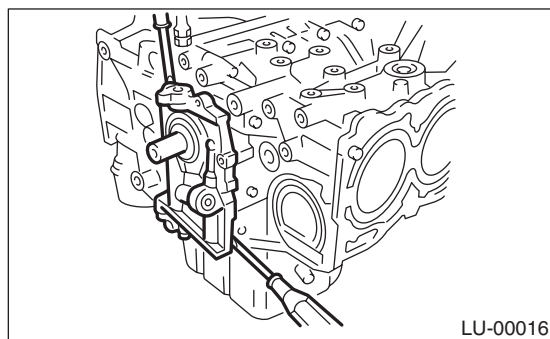

## B: INSTALLATION

Install in the reverse order of removal.  
Perform the following.

1) Apply liquid gasket to the mating surfaces of oil pump.

### Liquid gasket:

**THREE BOND 1215 (Part No. 004403007) or equivalent**

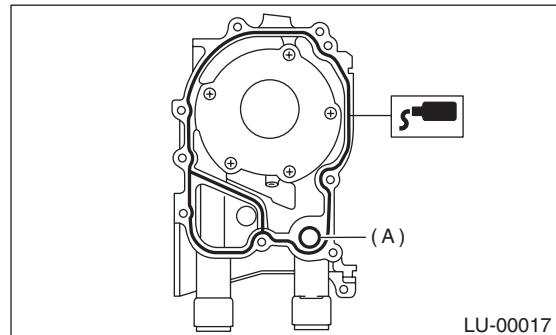

2) Replace O-ring (A) with a new part.

3) Apply a coat of engine oil to the inside of oil seal.

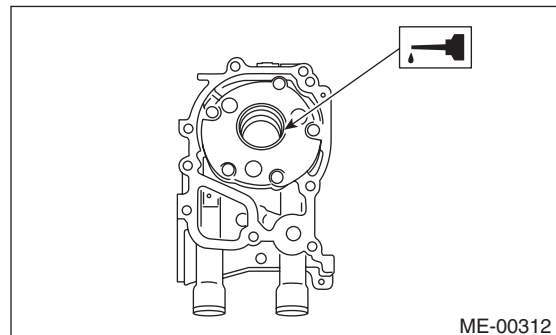

4) Position the oil pump, aligning the notched area with crankshaft, and push the oil pump straight.

### CAUTION:

- Make sure the oil seal lip is not folded.
- Be careful not to scratch the oil seal when installing oil pump on cylinder block.

5) Install the oil pump.

6) Apply liquid gasket to the three bolts thread.

### Liquid gasket:

**THREE BOND 1324 (Part No. 004403042) or equivalent**

### Tightening torque:

**6.4 N·m (0.65 kgf·m, 4.7 ft·lb)**

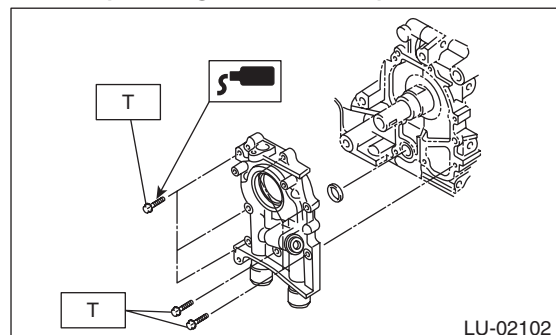

## C: DISASSEMBLY

Remove the screw which secures oil pump cover and then disassemble oil pump. Inscribe alignment marks on the inner and outer rotors so that they can be replaced in their original positions during reassembly.

### CAUTION:

**Before disassembling the oil pump, remove the relief valve.**

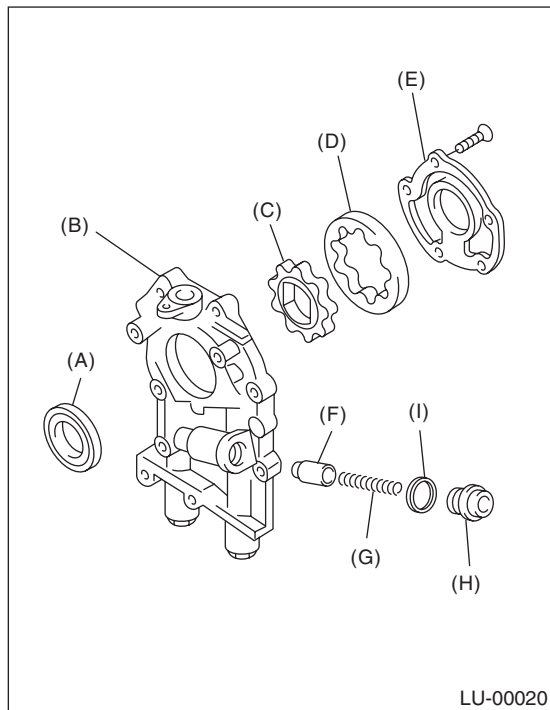

- (A) Oil seal
- (B) Pump case
- (C) Inner rotor
- (D) Outer rotor
- (E) Pump cover
- (F) Relief valve
- (G) Relief valve spring
- (H) Plug
- (I) Gasket

## D: ASSEMBLY

1) Using the ST, install the front oil seal.  
ST 499587100 OIL SEAL INSTALLER

### NOTE:

Use a new oil seal.

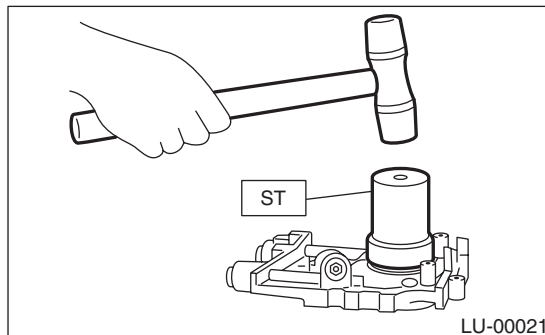

2) Apply a coat of engine oil to inner and outer rotors.

3) Assemble the inner and outer rotors in their original positions.

4) Assemble the oil relief valve and install relief valve spring and plug.

### NOTE:

Use a new gasket.

5) Install the oil pump cover.

### Tightening torque:

**T1: 5.4 N·m (0.55 kgf-m, 4.0 ft-lb)**

**T2: 44 N·m (4.5 kgf-m, 32.5 ft-lb)**

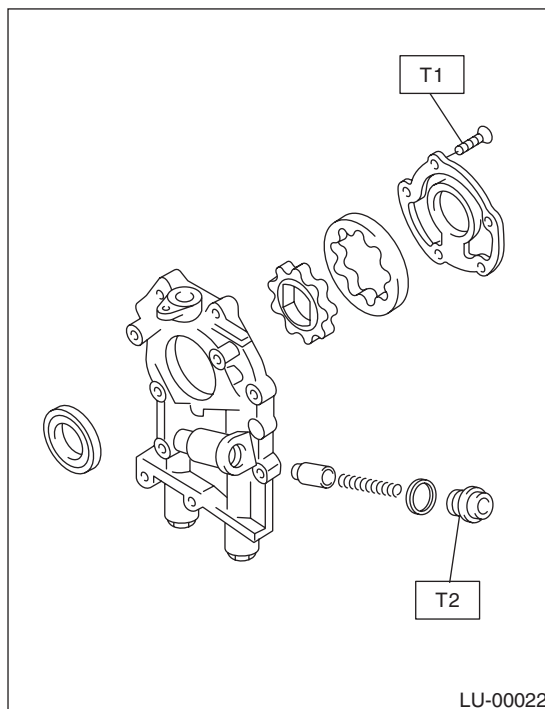

# Oil Pump

## LUBRICATION

### E: INSPECTION

#### 1. TIP CLEARANCE

Measure the tip clearance of rotors. If the clearance is out of specification, replace the rotors as a set.

**Tip clearance:**

**Standard**

**0.04 — 0.14 mm (0.0016 — 0.0055 in)**

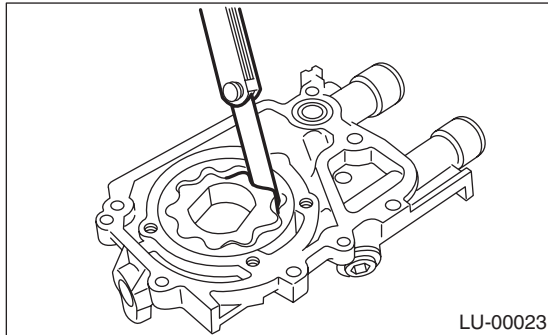

#### 2. CASE CLEARANCE

Measure the clearance between the outer rotor and the oil pump rotor housing. If clearance is out of standard, replace the oil pump case.

**Case clearance:**

**Standard**

**0.10 — 0.175 mm (0.0039 — 0.0069 in)**

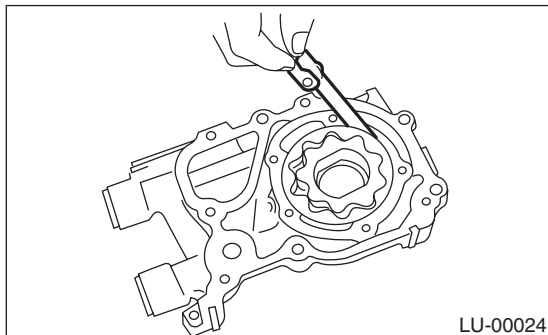

#### 3. SIDE CLEARANCE

Measure the clearance between oil pump inner rotor and pump cover. If the clearance is out of specification, replace the rotors and the pump body.

**Side clearance:**

**Standard**

**0.02 — 0.07 mm (0.0008 — 0.0028 in)**

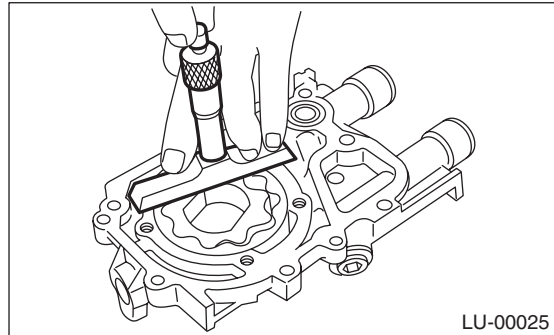

#### 4. OIL RELIEF VALVE

Check the valve for assembly condition and damage, and the relief valve spring for damage and deterioration. Replace the parts if defective.

**Relief valve spring:**

**Free length**

**73.7 mm (2.902 in)**

**Installed length**

**54.7 mm (2.154 in)**

**Load when installed**

**93.1 N (9.49 kgf, 20.88 lb)**

#### 5. OIL PUMP CASE

Check the oil pump case for worn shaft hole, clogged oil passage, worn rotor chamber, cracks and other faults.

#### 6. OIL SEAL

Check the oil seal lips for deformation, hardening, wear, etc. and replace if defective.