

13.Crank Pulley

A: REMOVAL

NOTE:

When replacing the single part, perform the work with the engine installed to vehicle body.

1) Remove the V-belts. <Ref. to ME(H4DOTC)-36, REMOVAL, V-belt.>

2) Use the ST to lock the crank pulley, and remove the crank pulley bolt.

ST 499977100 CRANK PULLEY WRENCH

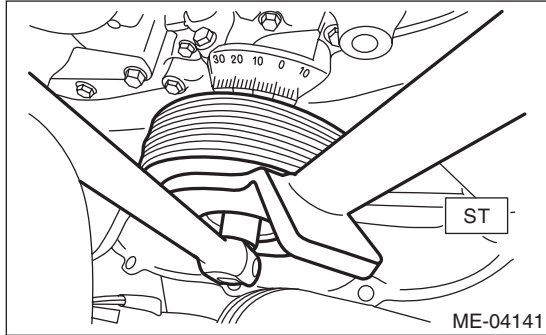

3) Remove the crank pulley.

B: INSTALLATION

1. METHOD WITHOUT ANGLE GAUGE

1) Clean the crankshaft thread using compressed air.

2) Install the crank pulley.

3) Apply engine oil to the crank pulley bolt seat and thread.

4) Tighten the crank pulley bolts.

(1) Use the ST to lock the crank pulley, and temporarily tighten the crank pulley bolt.

ST 499977100 CRANK PULLEY WRENCH

Tightening torque:

47 N·m (4.8 kgf·m, 34.7 ft·lb)

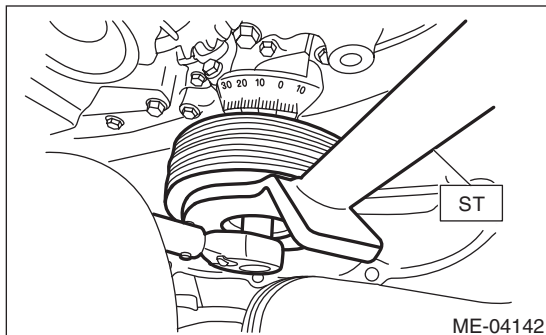

(2) Draw reference lines (A) and (B) using a marker to set the socket to the crank pulley bolt as shown in the figure.

ST 499977100 CRANK PULLEY WRENCH

NOTE:

Set the socket onto the crank pulley bolt so that reference lines (A) and (B) is visible.

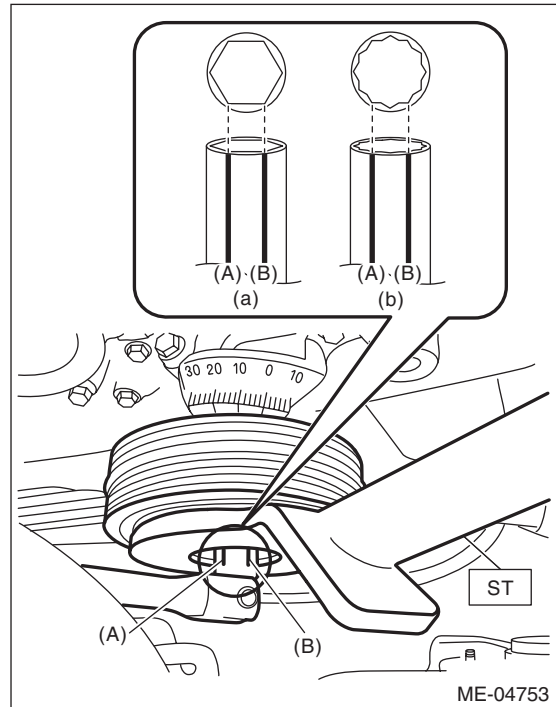

(a) When using 6-point socket

(b) When using 12-point socket

(3) Draw end line (C) on ST using a marker at the same position as reference line (B) was drawn on the socket in step (2).

ST 499977100 CRANK PULLEY WRENCH

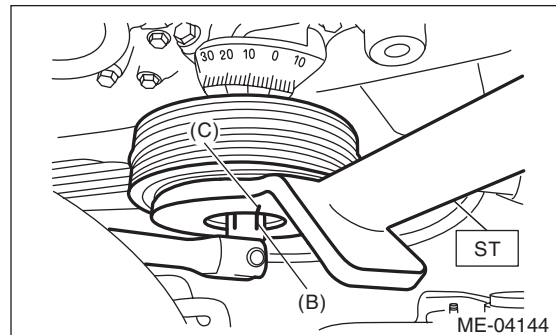

Crank Pulley

MECHANICAL

- (4) Use the ST to lock the crank pulley, and tighten the crank pulley bolt to the angle where reference line (A) and end line (C) are aligned.

ST 499977100 CRANK PULLEY WRENCH

NOTE:

It should be approx. 60° when reference line (A) and end line (C) are aligned.

Tightening angle:

$60^\circ \pm 5^\circ$

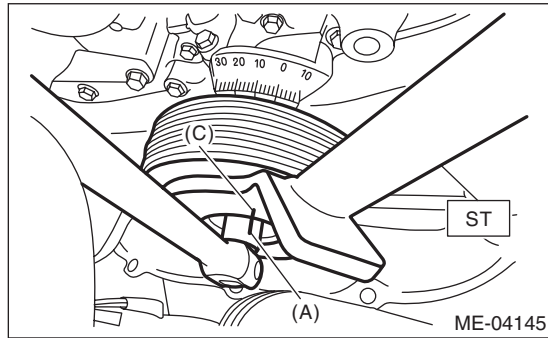

- 5) Install the V-belts. <Ref. to ME(H4DOTC)-37, INSTALLATION, V-belt.>

2. METHOD WITH ANGLE GAUGE

- 1) Clean the crankshaft thread using compressed air.
- 2) Install the crank pulley.
- 3) Apply engine oil to the crank pulley bolt seat and thread.
- 4) Tighten the crank pulley bolts.

- (1) Remove the radiator main fan motor assembly and radiator sub motor assembly. <Ref. to CO(H4DOTC)-24, REMOVAL, Radiator Main Fan and Fan Motor.> <Ref. to CO(H4DOTC)-27, REMOVAL, Radiator Sub Fan and Fan Motor.>

- (2) Use the ST1 to lock the crank pulley, and temporarily tighten the crank pulley bolt.

ST1 499977100 CRANK PULLEY WRENCH

Tightening torque:

47 N·m (4.8 kgf·m, 34.7 ft·lb)

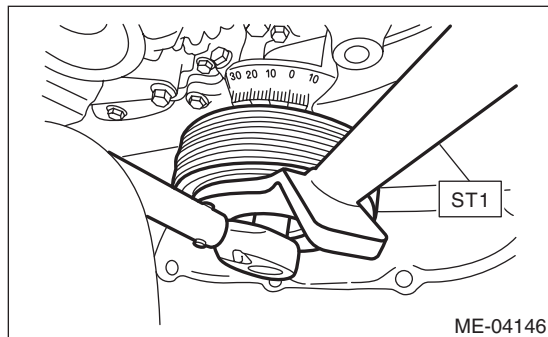

- (3) Set the ST2, use the ST1 to lock the crank pulley, and tighten the crank pulley bolt to the specified angle.

ST1 499977100 CRANK PULLEY WRENCH

ST2 18854AA000 ANGLE GAUGE

NOTE:

Attach the magnet used for securing the ST2 (ANGLE GAUGE) to ST1.

Tightening angle:

$60^\circ \pm 5^\circ$

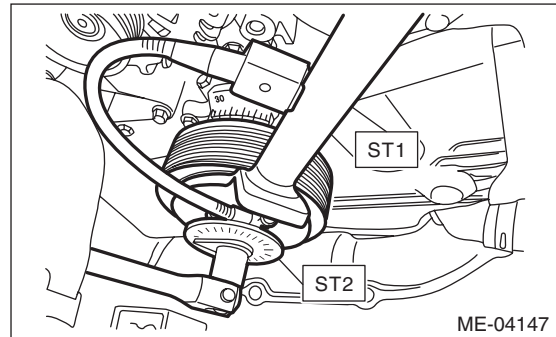

- (4) Install the radiator main fan motor assembly and radiator sub motor assembly. <Ref. to CO(H4DOTC)-25, INSTALLATION, Radiator Main Fan and Fan Motor.> <Ref. to CO(H4DOTC)-28, INSTALLATION, Radiator Sub Fan and Fan Motor.>

- 5) Install the V-belts. <Ref. to ME(H4DOTC)-37, INSTALLATION, V-belt.>

C: INSPECTION

- 1) Make sure the V-belt is not worn or damaged.
- 2) Check the tension of the front side belt. <Ref. to ME(H4DOTC)-38, INSPECTION, V-belt.>