

8. Valve Clearance

A: INSPECTION

Inspection and adjustment of valve clearance should be performed while engine is cold.

- 1) Lift-up the vehicle.
- 2) Remove the under cover.
- 3) Lower the vehicle.
- 4) Remove the collector cover.
- 5) Disconnect the ground cable from battery.

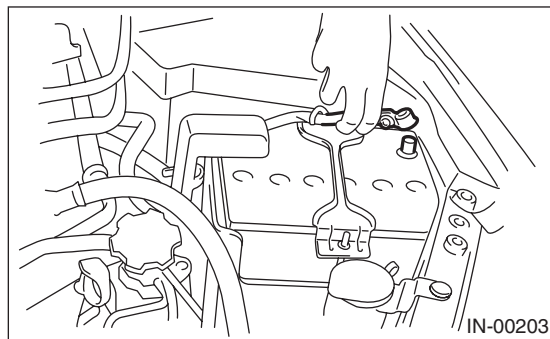

6) Remove the air intake duct. <Ref. to IN(H4DOTC)-9, REMOVAL, Air Intake Duct.>

7) Remove a bolt which secures timing belt cover (RH).

8) Loosen the remaining bolts which secure timing belt cover (RH), then remove the timing belt cover.

9) When inspecting #1 and #3 cylinders:

(1) Remove the air cleaner case. <Ref. to IN(H4DOTC)-8, REMOVAL, Air Cleaner Case.>

(2) Disconnect the connector of ignition coil.

(3) Remove the ignition coil.

(4) Place a suitable container under the vehicle.

(5) Disconnect the PCV hose from rocker cover (RH).

(6) Remove the bolts, then remove the rocker cover (RH).

10) When inspecting #2 and #4 cylinders:

(1) Disconnect the battery cable, and then remove the battery and battery carrier.

(2) Disconnect the connector of ignition coil.

(3) Remove the ignition coil.

(4) Place a suitable container under the vehicle.

(5) Disconnect the PCV hose from rocker cover (LH).

(6) Remove the bolts, then remove the rocker cover (LH).

11) Turn the crank pulley clockwise until arrow mark on the camshaft sprocket is set to position shown in the figure.

NOTE:

Turn the crankshaft using socket wrench.

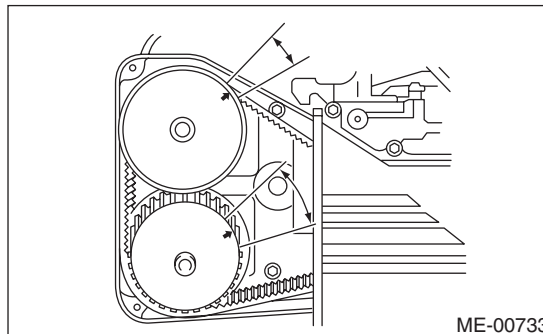

12) Measure the #1 cylinder intake valve and #3 cylinder exhaust valve clearance by using thickness gauge (A).

NOTE:

- Insert a thickness gauge in a direction as horizontal as possible with respect to the valve lifter.
- Measure the exhaust valve clearances while lifting-up the vehicle.

Valve clearance

Intake:

$0.20 \pm 0.02 \text{ mm } (0.0079 \pm 0.0008 \text{ in})$

Exhaust:

$0.35 \pm 0.02 \text{ mm } (0.0138 \pm 0.0008 \text{ in})$

- If the measured value is not within specification, take notes of the value in order to adjust the valve clearance later on.

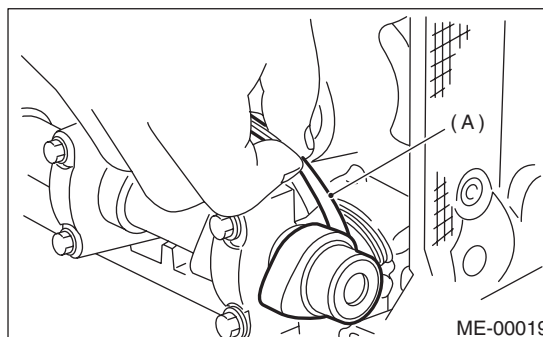

13) If necessary, adjust the valve clearance. <Ref. to ME(H4DOTC)-26, ADJUSTMENT, Valve Clearance.>

Valve Clearance

MECHANICAL

14) Further turn the crank pulley clockwise and then measure the valve clearances again.

(1) Set the arrow mark on cam sprocket to the position shown in the figure, and measure the #2 cylinder exhaust valve and #3 cylinder intake valve clearances.

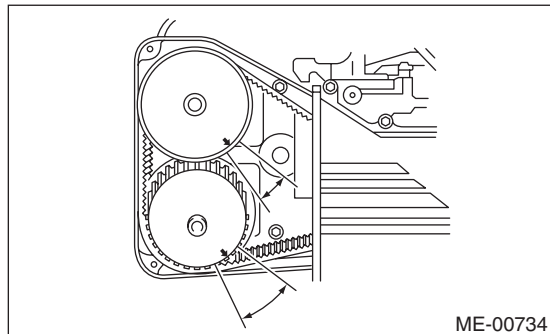

(2) Set the arrow mark on cam sprocket to the position shown in the figure, and measure the #2 cylinder intake valve and #4 cylinder exhaust valve clearances.

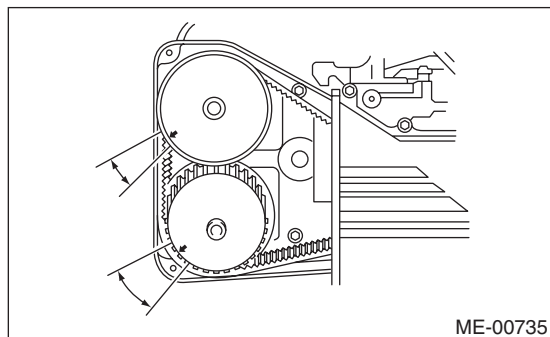

(3) Set the arrow mark on cam sprocket to the position shown in the figure, and measure the #1 cylinder exhaust valve and #4 cylinder intake valve clearances.

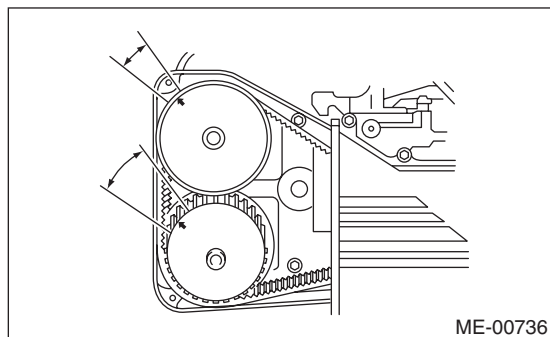

15) After inspection, install the related parts in the reverse order of removal.

B: ADJUSTMENT

CAUTION:

Adjustment of valve clearance should be performed while engine is cold.

1) Measure all the valve clearances. <Ref. to ME(H4DOTC)-25, INSPECTION, Valve Clearance.>

NOTE:

Record each valve clearance after measurement.

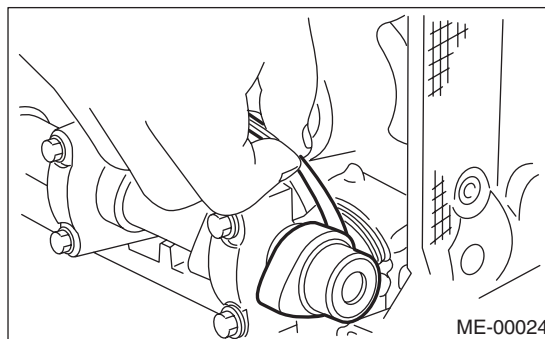

2) Remove the camshaft. <Ref. to ME(H4DOTC)-52, REMOVAL, Camshaft.>

3) Remove the valve lifter.

4) Measure the thickness of valve lifter using micrometer.

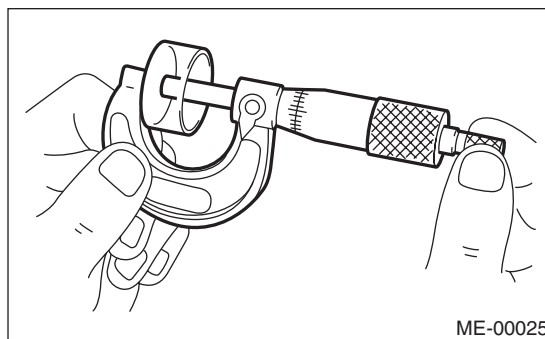

5) Select a valve lifter of suitable thickness from the following table using the measured valve clearance and valve lifter thickness.

Unit: (mm)	
Intake valve:	$S = (V + T) - 0.20$
Exhaust valve:	$S = (V + T) - 0.35$
S:	Valve lifter thickness required
V:	Measured valve clearance
T:	Valve lifter thickness to be used

Valve Clearance

MECHANICAL

Part No.	Thickness mm (in)
13228 AB102	4.68 (0.1843)
13228 AB112	4.69 (0.1846)
13228 AB122	4.70 (0.1850)
13228 AB132	4.71 (0.1854)
13228 AB142	4.72 (0.1858)
13228 AB152	4.73 (0.1862)
13228 AB162	4.74 (0.1866)
13228 AB172	4.75 (0.1870)
13228 AB182	4.76 (0.1874)
13228 AB192	4.77 (0.1878)
13228 AB202	4.78 (0.1882)
13228 AB212	4.79 (0.1886)
13228 AB222	4.80 (0.1890)
13228 AB232	4.81 (0.1894)
13228 AB242	4.82 (0.1898)
13228 AB252	4.83 (0.1902)
13228 AB262	4.84 (0.1906)
13228 AB272	4.85 (0.1909)
13228 AB282	4.86 (0.1913)
13228 AB292	4.87 (0.1917)
13228 AB302	4.88 (0.1921)
13228 AB312	4.89 (0.1925)
13228 AB322	4.90 (0.1929)
13228 AB332	4.91 (0.1933)
13228 AB342	4.92 (0.1937)
13228 AB352	4.93 (0.1941)
13228 AB362	4.94 (0.1945)
13228 AB372	4.95 (0.1949)
13228 AB382	4.96 (0.1953)
13228 AB392	4.97 (0.1957)
13228 AB402	4.98 (0.1961)
13228 AB412	4.99 (0.1965)
13228 AB422	5.00 (0.1969)
13228 AB432	5.01 (0.1972)
13228 AB442	5.02 (0.1976)
13228 AB452	5.03 (0.1980)
13228 AB462	5.04 (0.1984)
13228 AB472	5.05 (0.1988)
13228 AB482	5.06 (0.1992)
13228 AB492	5.07 (0.1996)
13228 AB502	5.08 (0.2000)
13228 AB512	5.09 (0.2004)
13228 AB522	5.10 (0.2008)
13228 AB532	5.11 (0.2012)
13228 AB542	5.12 (0.2016)
13228 AB552	5.13 (0.2020)
13228 AB562	5.14 (0.2024)
13228 AB572	5.15 (0.2028)
13228 AB582	5.16 (0.2031)
13228 AB592	5.17 (0.2035)
13228 AB602	5.18 (0.2039)
13228 AB612	5.19 (0.2043)

Part No.	Thickness mm (in)
13228 AB622	5.20 (0.2047)
13228 AB632	5.21 (0.2051)
13228 AB642	5.22 (0.2055)
13228 AB652	5.23 (0.2059)
13228 AB662	5.24 (0.2063)
13228 AB672	5.25 (0.2067)
13228 AB682	5.26 (0.2071)
13228 AB692	5.27 (0.2075)
13228 AB702	4.38 (0.1724)
13228 AB712	4.40 (0.1732)
13228 AB722	4.42 (0.1740)
13228 AB732	4.44 (0.1748)
13228 AB742	4.46 (0.1756)
13228 AB752	4.48 (0.1764)
13228 AB762	4.50 (0.1771)
13228 AB772	4.52 (0.1780)
13228 AB782	4.54 (0.1787)
13228 AB792	4.56 (0.1795)
13228 AB802	4.58 (0.1803)
13228 AB812	4.60 (0.1811)
13228 AB822	4.62 (0.1819)
13228 AB832	4.64 (0.1827)
13228 AB842	4.66 (0.1835)
13228 AB852	5.29 (0.2083)
13228 AB862	5.31 (0.2091)
13228 AB872	5.33 (0.2098)
13228 AB882	5.35 (0.2106)
13228 AB892	5.37 (0.2114)
13228 AB902	5.39 (0.2122)
13228 AB912	5.41 (0.2123)
13228 AB922	5.43 (0.2138)
13228 AB932	5.45 (0.2146)
13228 AB942	5.47 (0.2154)
13228 AB952	5.49 (0.2161)
13228 AB962	5.51 (0.2169)
13228 AB972	5.53 (0.2177)
13228 AB982	5.55 (0.2185)
13228 AB992	5.57 (0.2193)
13228 AC002	5.59 (0.2201)
13228 AC012	5.61 (0.2209)
13228 AC022	5.63 (0.2217)
13228 AC032	5.65 (0.2224)

- 6) Inspect all valves for valve clearance again at this time. If the valve clearance is not correct, repeat the procedure over again from the first step.
- 7) After inspection, install the related parts in the reverse order of removal.