

Radiator Main Fan and Fan Motor

COOLING

8. Radiator Main Fan and Fan Motor

A: REMOVAL

- 1) Set the vehicle on a lift.
- 2) Remove the collector cover.
- 3) Disconnect the ground cable from battery.

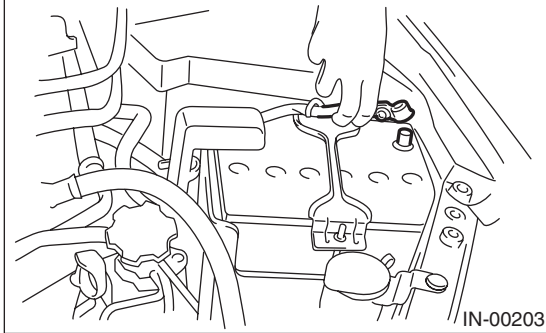

- 4) Remove the hood stay holder.

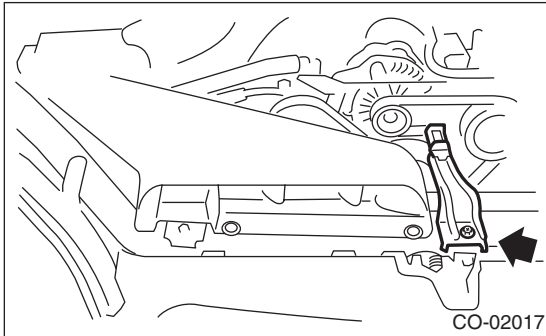

- 5) Remove the air intake duct. <Ref. to IN(H6DO)-8, REMOVAL, Air Intake Duct.>
- 6) Disconnect the connector from radiator fan control unit.

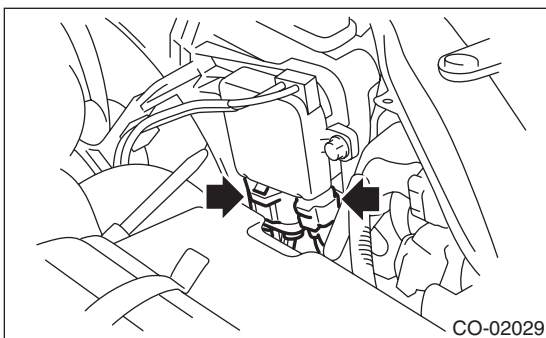

- 7) Lift-up the vehicle.
- 8) Remove the under cover.
- 9) Drain engine coolant completely. <Ref. to CO(H6DO)-10, DRAINING OF ENGINE COOLANT, REPLACEMENT, Engine Coolant.>
- 10) Remove the ATF hose from the clip of the radiator main fan shroud.
- 11) Remove the radiator main fan motor harness from the clip.
- 12) Lower the vehicle.

- 13) Remove the reservoir tank. <Ref. to CO(H6DO)-23, REMOVAL, Reservoir Tank.>
- 14) Disconnect the inlet hose from radiator.

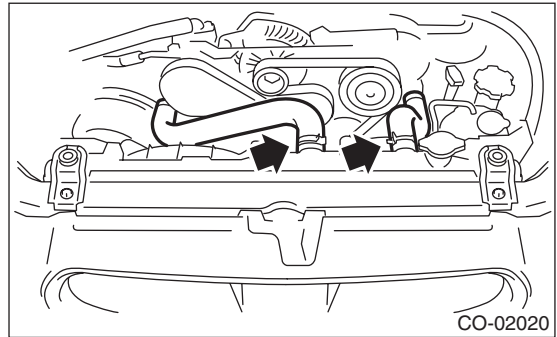

- 15) Remove the radiator sub fan motor assembly.

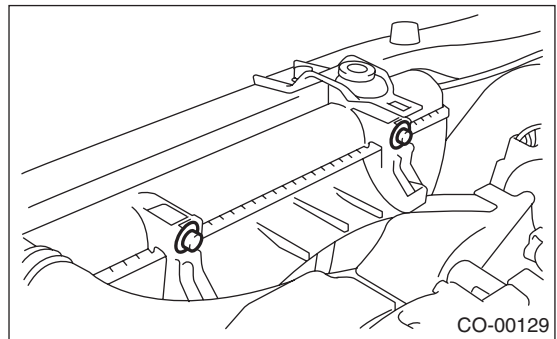

- 16) Remove the radiator main fan motor assembly.

NOTE:

When removing the main fan assembly with lifting it up, the main fan shroud contacts to inlet part of engine coolant. To avoid contacting it, move the main fan assembly to sub fan assembly side before removal.

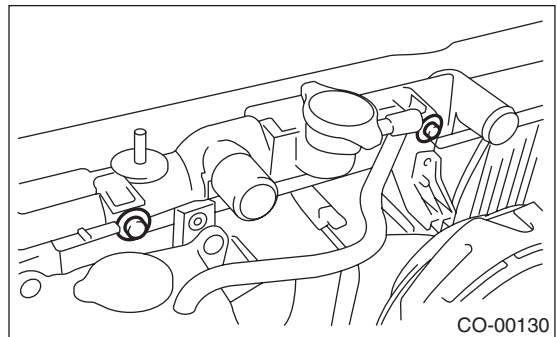

B: INSTALLATION

Install in the reverse order of removal.

Tightening torque:

7.5 N·m (0.76 kgf-m, 5.5 ft-lb)

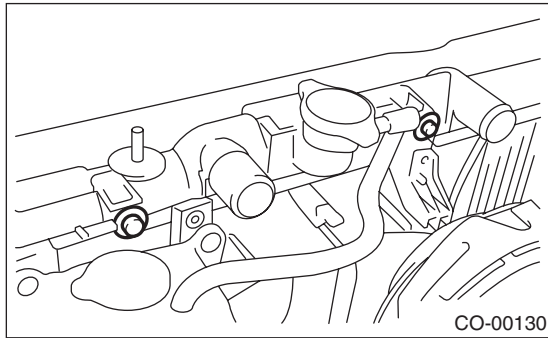

D: ASSEMBLY

Assemble in the reverse order of disassembly.

Tightening torque:

3.8 N·m (0.39 kgf-m, 2.8 ft-lb)

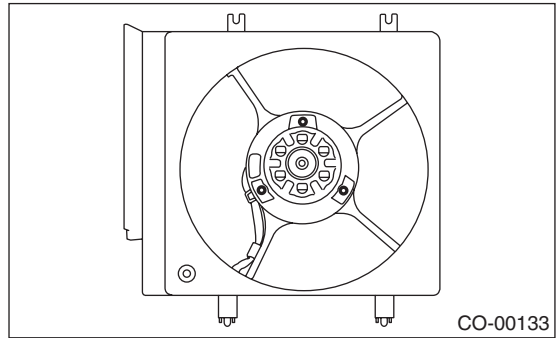

C: DISASSEMBLY

1) Remove the nut which holds fan to fan motor and shroud assembly.

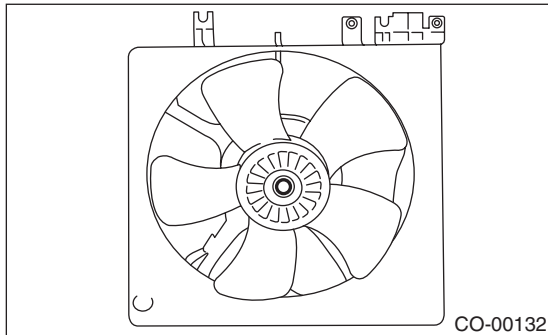

Tightening torque:

6.2 N·m (0.63 kgf-m, 4.6 ft-lb)

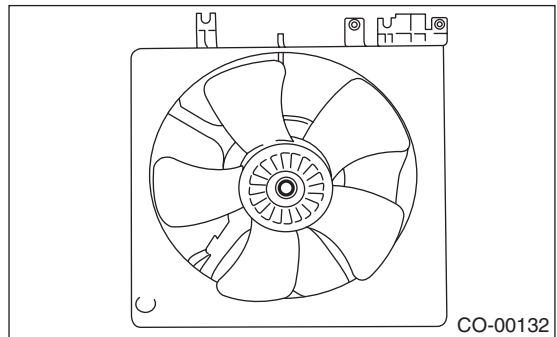

2) Remove the clip which holds the fan motor onto the shroud.

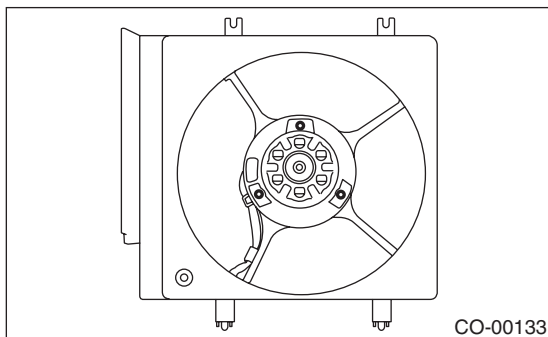

Radiator Main Fan and Fan Motor

COOLING

E: INSPECTION

1) Disconnect the connector from radiator fan control unit.

NOTE:

Do not remove the main fan motor harness connector.

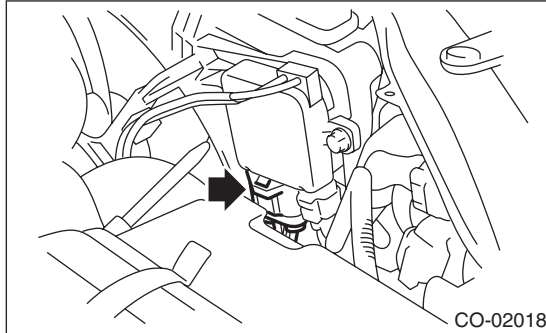

2) Connect the battery to radiator fan control unit as shown in the figure.

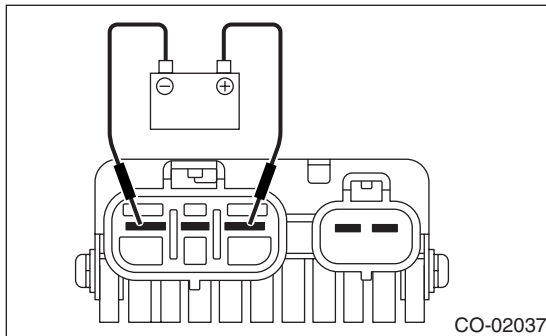

3) Check the fan motor for operations. If it does not operate, check the fan motor.