

9. Radiator Sub Fan and Fan Motor

A: REMOVAL

- 1) Set the vehicle on a lift.
- 2) Remove the collector cover.
- 3) Disconnect the ground cable from battery.

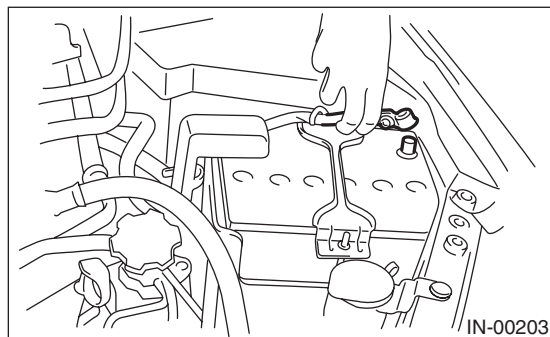

- 4) Remove the hood stay holder.

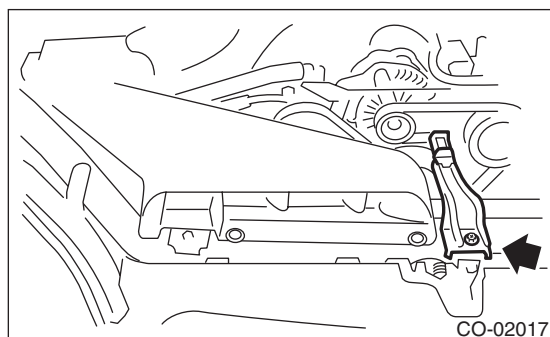

- 5) Remove the air intake duct. <Ref. to IN(H6DO)-8, REMOVAL, Air Intake Duct.>

- 6) Disconnect the connector from radiator fan control unit.

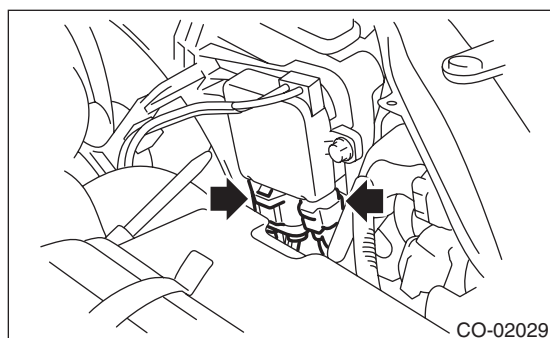

- 7) Remove the bolts which hold the sub shroud to the radiator.

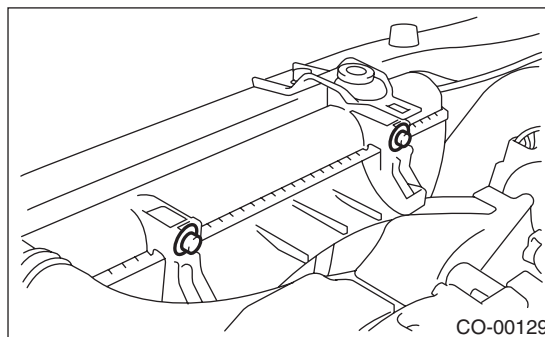

- 8) Lift-up the vehicle.
- 9) Remove the under cover.
- 10) Remove the radiator sub fan shroud through the under side of vehicle.

B: INSTALLATION

Install in the reverse order of removal.

Tightening torque:

7.5 N·m (0.76 kgf-m, 5.5 ft-lb)

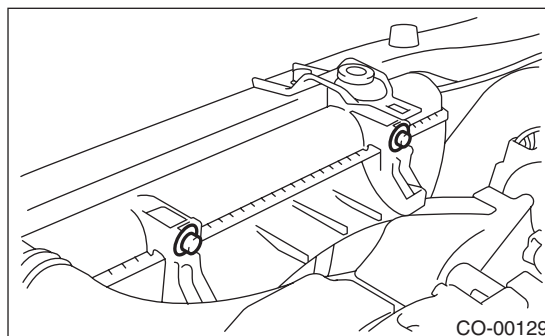

Radiator Sub Fan and Fan Motor

COOLING

C: DISASSEMBLY

1) Remove the nut which holds fan to fan motor and shroud assembly.

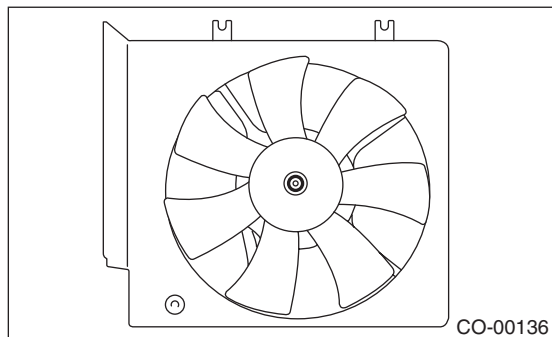

2) Remove the clip which holds the fan motor onto the shroud.

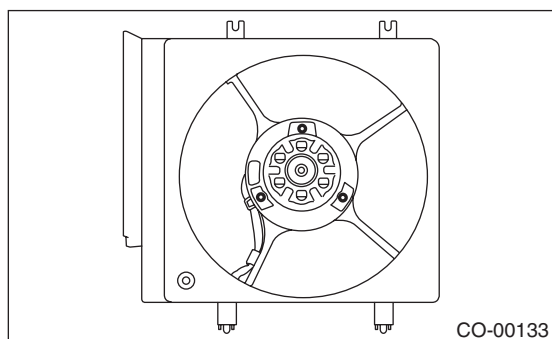

3) Remove the bolts which hold the radiator fan control unit to the shroud.

D: ASSEMBLY

Assemble in the reverse order of disassembly.

Radiator fan control unit bolt tightening torque:
5.4 N·m (0.55 kgf·m, 4.0 ft·lb)

Tightening torque:
3.8 N·m (0.39 kgf·m, 2.8 ft·lb)

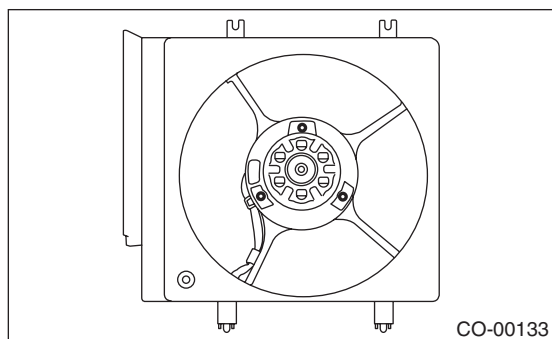

Tightening torque:
6.2 N·m (0.63 kgf·m, 4.6 ft·lb)

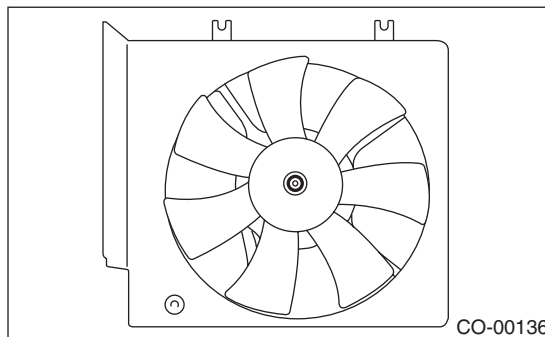

E: INSPECTION

1) Disconnect the connector from radiator fan control unit.

NOTE:

Do not remove the main fan motor harness connector.

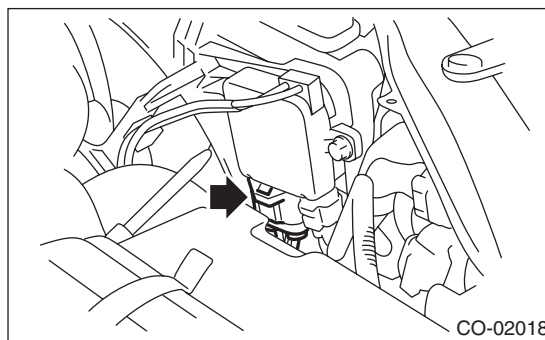

2) Connect the battery to radiator fan control unit as shown in the figure.

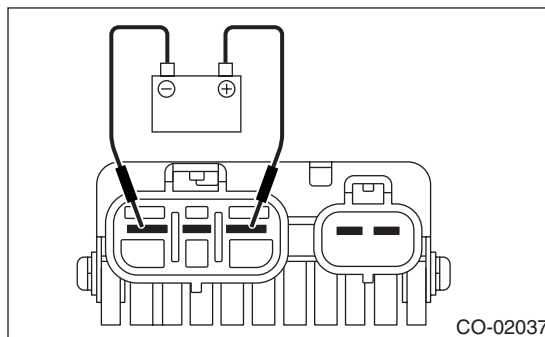

3) Check the fan motor for operations. If it does not operate, check the fan motor.