

# Malfunction Indicator Light

ENGINE (DIAGNOSTICS)

---

## 15. Malfunction Indicator Light

### A: PROCEDURE

1. Activation of malfunction indicator light. <Ref. to EN(H6DO)(diag)-49, ACTIVATION OF MALFUNCTION INDICATOR LIGHT, Malfunction Indicator Light.>
↓
2. Malfunction indicator light does not come on. <Ref. to EN(H6DO)(diag)-50, MALFUNCTION INDICATOR LIGHT DOES NOT COME ON, Malfunction Indicator Light.>
↓
3. Malfunction indicator light does not go off. <Ref. to EN(H6DO)(diag)-52, MALFUNCTION INDICATOR LIGHT DOES NOT GO OFF., Malfunction Indicator Light.>
↓
4. Malfunction indicator light does not go off. <Ref. to EN(H6DO)(diag)-53, MALFUNCTION INDICATOR LIGHT DOES NOT BLINK., Malfunction Indicator Light.>
↓
5. Malfunction indicator light keep brinking. <Ref. to EN(H6DO)(diag)-55, MALFUNCTION INDICATOR LIGHT REMAINS BLINKING., Malfunction Indicator Light.>

## B: ACTIVATION OF MALFUNCTION INDICATOR LIGHT

1) When the ignition switch is turned to ON (engine OFF), the malfunction indicator light (A) in the combination meter illuminates.

**NOTE:**

If the malfunction indicator light does not illuminate, perform diagnostics of the malfunction indicator light circuit or the combination meter circuit. <Ref. to EN(H6DO)(diag)-50, MALFUNCTION INDICATOR LIGHT DOES NOT COME ON, Malfunction Indicator Light.>

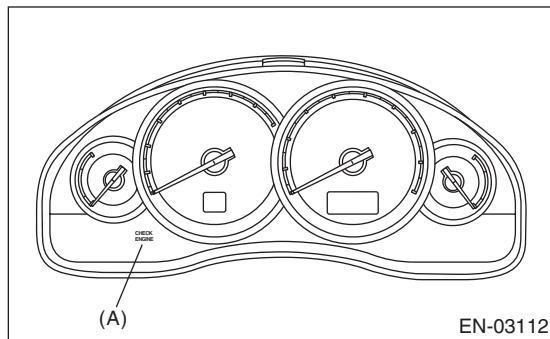

2) After starting the engine, the malfunction indicator light goes out. If it does not go off, either the engine or emission control system has malfunction.

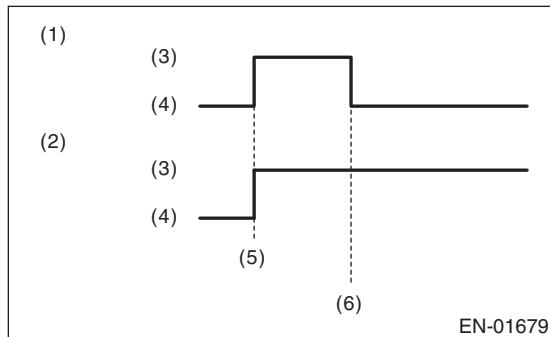

- (1) No faulty
- (2) Trouble occurs
- (3) ON
- (4) OFF
- (5) Ignition switch ON
- (6) Engine start

3) Turn the ignition switch to OFF and connect the test mode connector.

(1) When the ignition switch is turned to ON (engine OFF), the malfunction indicator light illuminates.

(2) After the engine starts, malfunction indicator light blinks in a cycle of 0.5 Hz. (During diagnosis)

(3) Malfunction indicator light blinks at a cycle of 3 Hz after diagnosis if there is no trouble. Malfunction indicator light illuminates if faulty.

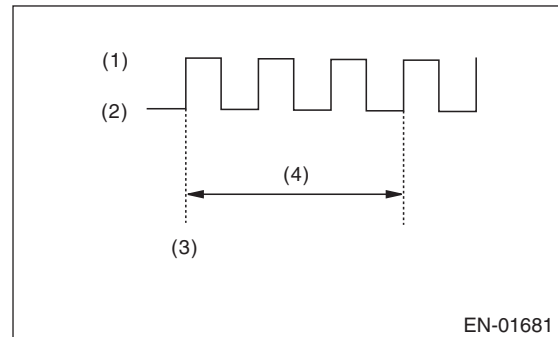

- (1) ON
- (2) OFF
- (3) Ignition switch ON
- (4) 1 second



# Malfunction Indicator Light

ENGINE (DIAGNOSTICS)

Step	Check	Yes	No
<b>3</b> <b>CHECK ECM CONNECTOR.</b> Check the connection of ECM connector.	Is the ECM connector correctly connected?	Replace the ECM. <Ref. to FU(H6DO)-33, Engine Control Module (ECM).>	Repair the connection of ECM connector.
<b>4</b> <b>CHECK HARNESS BETWEEN COMBINATION METER AND ECM CONNECTOR.</b> 1) Turn the ignition switch to OFF. 2) Remove the combination meter. <Ref. to IDI-14, Combination Meter.> 3) Disconnect the connector from ECM and combination meter. 4) Measure the resistance of harness between ECM and combination meter connector. <b>Connector &amp; terminal</b> <b>(B136) No. 11 — (i10) No. 16:</b>	Is the resistance less than 1 $\Omega$ ?	Go to step 5.	Repair the harness and connector. NOTE: In this case, repair the following item: • Open circuit in harness between ECM and combination meter connector • Poor contact in coupling connector
<b>5</b> <b>CHECK POOR CONTACT.</b> Check poor contact of combination meter connector.	Is there poor contact in combination meter connector?	Repair the poor contact of combination meter connector.	Go to step 6.
<b>6</b> <b>CHECK HARNESS BETWEEN COMBINATION METER AND IGNITION SWITCH CONNECTOR.</b> 1) Turn the ignition switch to ON. 2) Measure the voltage between combination meter connector and chassis ground. <b>Connector &amp; terminal</b> <b>(i10) No. 3 (+) — Chassis ground (-):</b> <b>(i10) No. 4 (+) — Chassis ground (-):</b>	Is the voltage more than 10 V?	Replace the combination meter circuit board. <Ref. to IDI-14, Combination Meter.>	Check the following item and repair if necessary. NOTE: • Blown out of fuse (No. 5) • Open or short circuit in harness between fuse (No. 5) and battery terminal • Poor contact in ignition switch connector

# Malfunction Indicator Light

ENGINE (DIAGNOSTICS)

## D: MALFUNCTION INDICATOR LIGHT DOES NOT GO OFF.

### DIAGNOSIS:

The malfunction indicator light circuit is shorted.

### TROUBLE SYMPTOM:

Although malfunction indicator light comes on when the engine runs, DTC is not shown on the Subaru Select Monitor display.

### WIRING DIAGRAM:

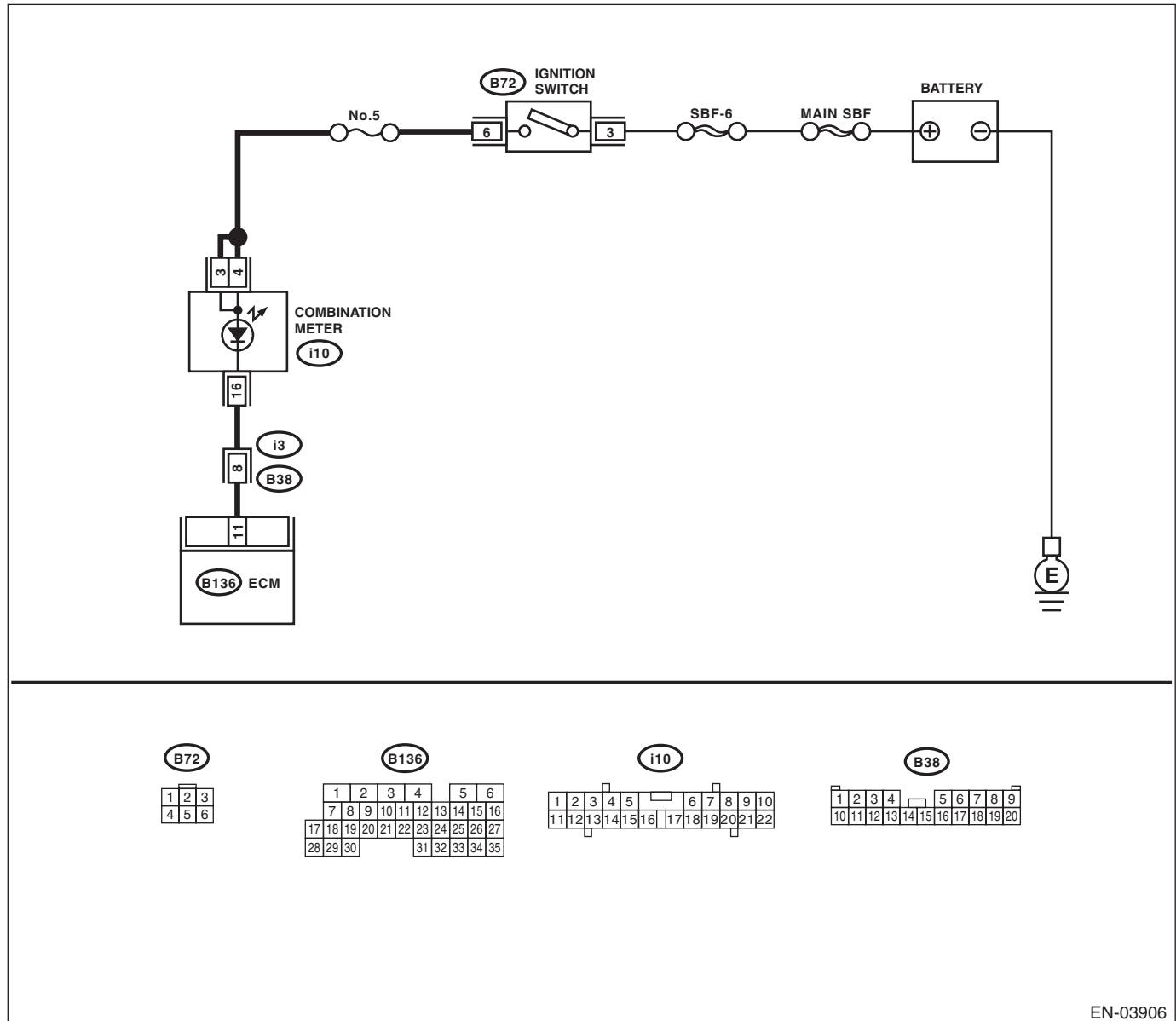

EN-03906

Step	Check	Yes	No
<b>1</b> <b>CHECK HARNESS BETWEEN COMBINATION METER AND ECM CONNECTOR.</b> 1) Turn the ignition switch to OFF. 2) Disconnect the connectors from ECM. 3) Turn the ignition switch to ON.	Does the malfunction indicator light illuminate?	Repair the short circuit of harness between combination meter and ECM connector.	Replace the ECM. <Ref. to FU(H6DO)-33, Engine Control Module (ECM).>

# Malfunction Indicator Light

## E: MALFUNCTION INDICATOR LIGHT DOES NOT BLINK.

### DIAGNOSIS:

- The malfunction indicator light circuit is open or shorted.
- Test mode connector circuit is open.

### TROUBLE SYMPTOM:

Malfunction indicator light does not blink during Inspection Mode.

### WIRING DIAGRAM:

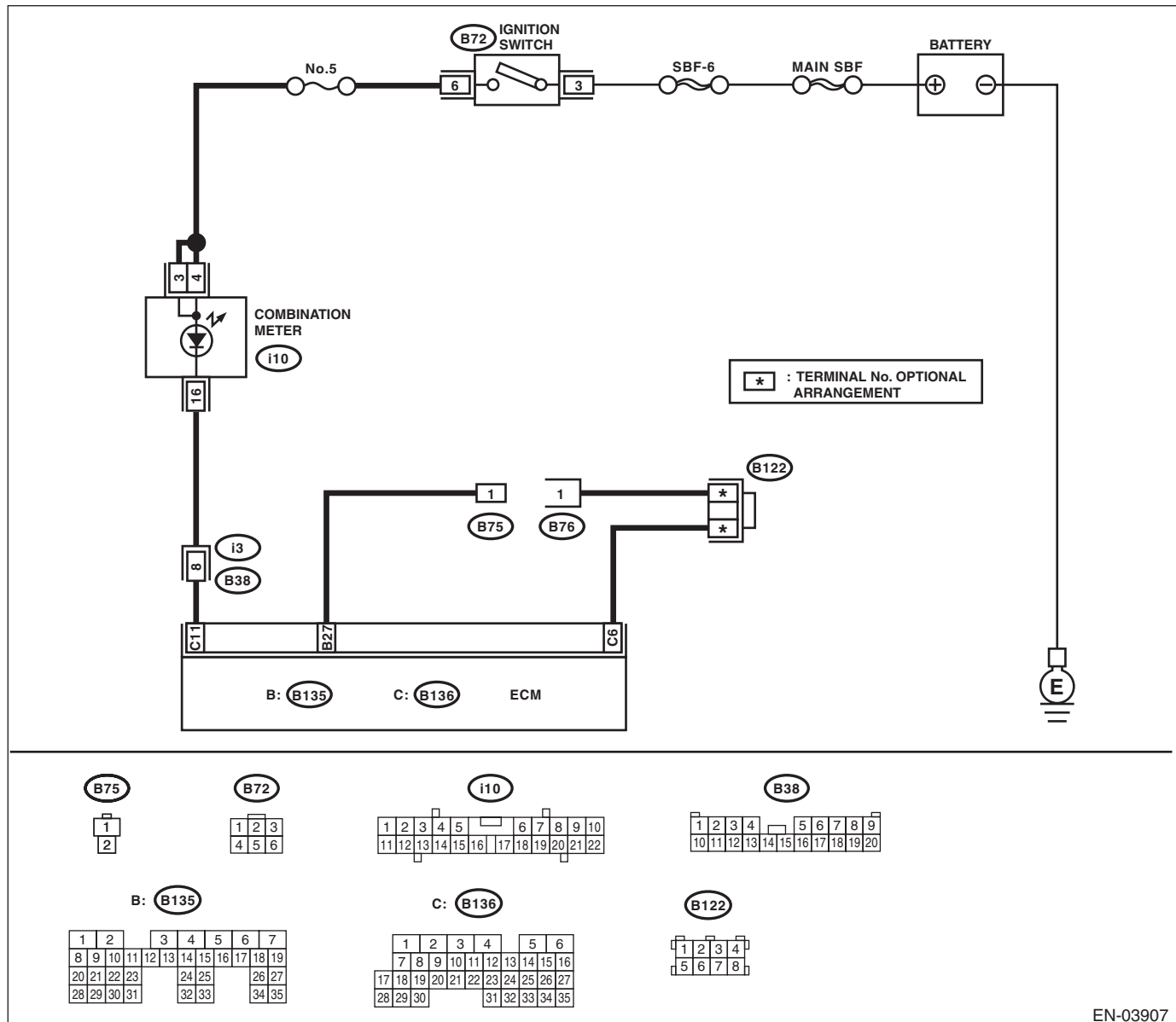

# Malfunction Indicator Light

## ENGINE (DIAGNOSTICS)

Step	Check	Yes	No
<b>1 CHECK STATUS OF MALFUNCTION INDICATOR LIGHT.</b> 1) Turn the ignition switch to OFF. 2) Disconnect the test mode connector. 3) Turn the ignition switch to ON. (engine OFF)	Does the malfunction indicator light illuminate?	Go to step 2.	Repair the malfunction indicator light circuit. <Ref. to EN(H6DO)(diag)-50, MALFUNCTION INDICATOR LIGHT DOES NOT COME ON, Malfunction Indicator Light.>
<b>2 CHECK HARNESS BETWEEN COMBINATION METER AND ECM CONNECTOR.</b> 1) Turn the ignition switch to OFF. 2) Disconnect the connectors from ECM. 3) Turn the ignition switch to ON.	Does the malfunction indicator light illuminate?	Repair the short circuit of harness between combination meter and ECM connector.	Go to step 3.
<b>3 CHECK HARNESS BETWEEN TEST MODE CONNECTOR AND CHASSIS GROUND.</b> 1) Turn the ignition switch to OFF. 2) Disconnect the connectors from ECM. 3) Measure the resistance of harness between test mode connector and ECM connector.  <i>Connector &amp; terminal (B76) No. 1 — (B136) No. 6:</i>	Is the resistance less than 1 $\Omega$ ?	Go to step 4.	Repair the harness and connector.  NOTE: In this case, repair the following item: • Open circuit of harness between test mode connector and chassis ground
<b>4 CHECK POOR CONTACT.</b> Check the poor contact of ECM connector.	Is there poor contact in ECM connector?	Repair the poor contact of ECM connector.	Go to step 5.
<b>5 CHECK HARNESS BETWEEN ECM AND TEST MODE CONNECTOR.</b> 1) Connect the test mode connector. 2) Measure the resistance of harness between ECM and chassis ground.  <i>Connector &amp; terminal (B135) No. 27 — Chassis ground:</i>	Is the resistance less than 1 $\Omega$ ?	Go to step 6.	Repair the open circuit of harness between ECM and test mode connector.
<b>6 CHECK POOR CONTACT.</b> Check the poor contact of ECM connector.	Is there poor contact in ECM connector?	Repair the poor contact of ECM connector.	Replace the ECM. <Ref. to FU(H6DO)-33, Engine Control Module (ECM).>

# Malfunction Indicator Light

## F: MALFUNCTION INDICATOR LIGHT REMAINS BLINKING.

### DIAGNOSIS:

Test mode connector circuit is shorted.

### TROUBLE SYMPTOM:

Malfunction indicator light blinks when test mode connector is not connected.

### WIRING DIAGRAM:

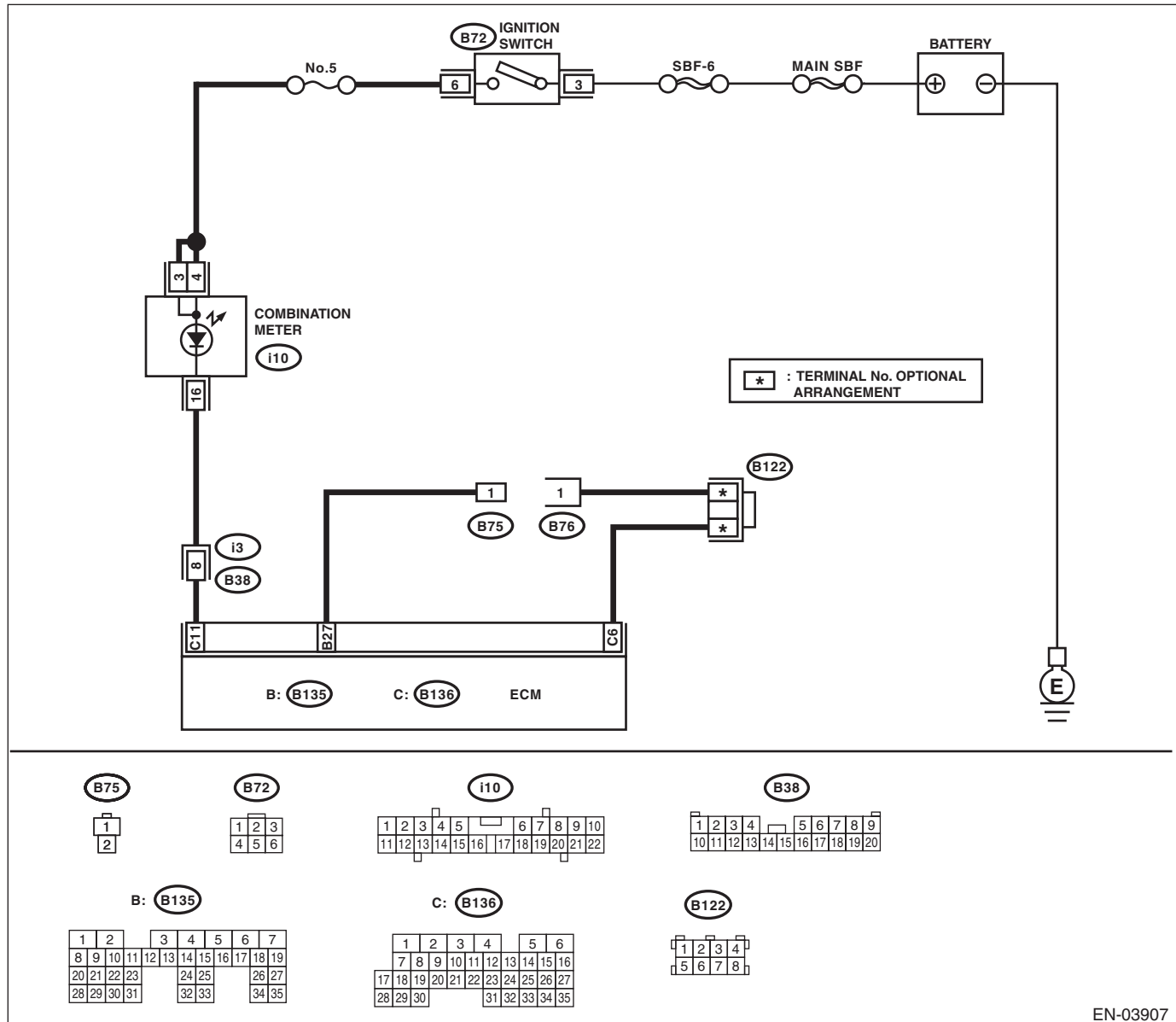



## Malfunction Indicator Light

### ENGINE (DIAGNOSTICS)

Step	Check	Yes	No
<b>1</b> <b>CHECK TEST MODE CONNECTOR.</b> 1) Disconnect the test mode connector. 2) Turn the ignition switch to ON.	Does the malfunction indicator light blink?	Go to step 2.	System is normal. NOTE: Malfunction indicator light blinks when test mode connector is connected.
<b>2</b> <b>CHECK HARNESS BETWEEN ECM CONNECTOR AND CHASSIS GROUND TERMINAL.</b> 1) Turn the ignition switch to OFF. 2) Disconnect the connectors from ECM. 3) Measure the resistance of harness between ECM connector and chassis ground. <b>Connector &amp; terminal</b> <b>(B135) No. 27 — Chassis ground:</b>	Is the resistance less than 5 $\Omega$ ?	Repair the short circuit of harness between ECM and test mode connector.	Replace the ECM. <Ref. to FU(H6DO)-33, Engine Control Module (ECM).>