

General Description

EXHAUST

1. General Description

A: COMPONENT

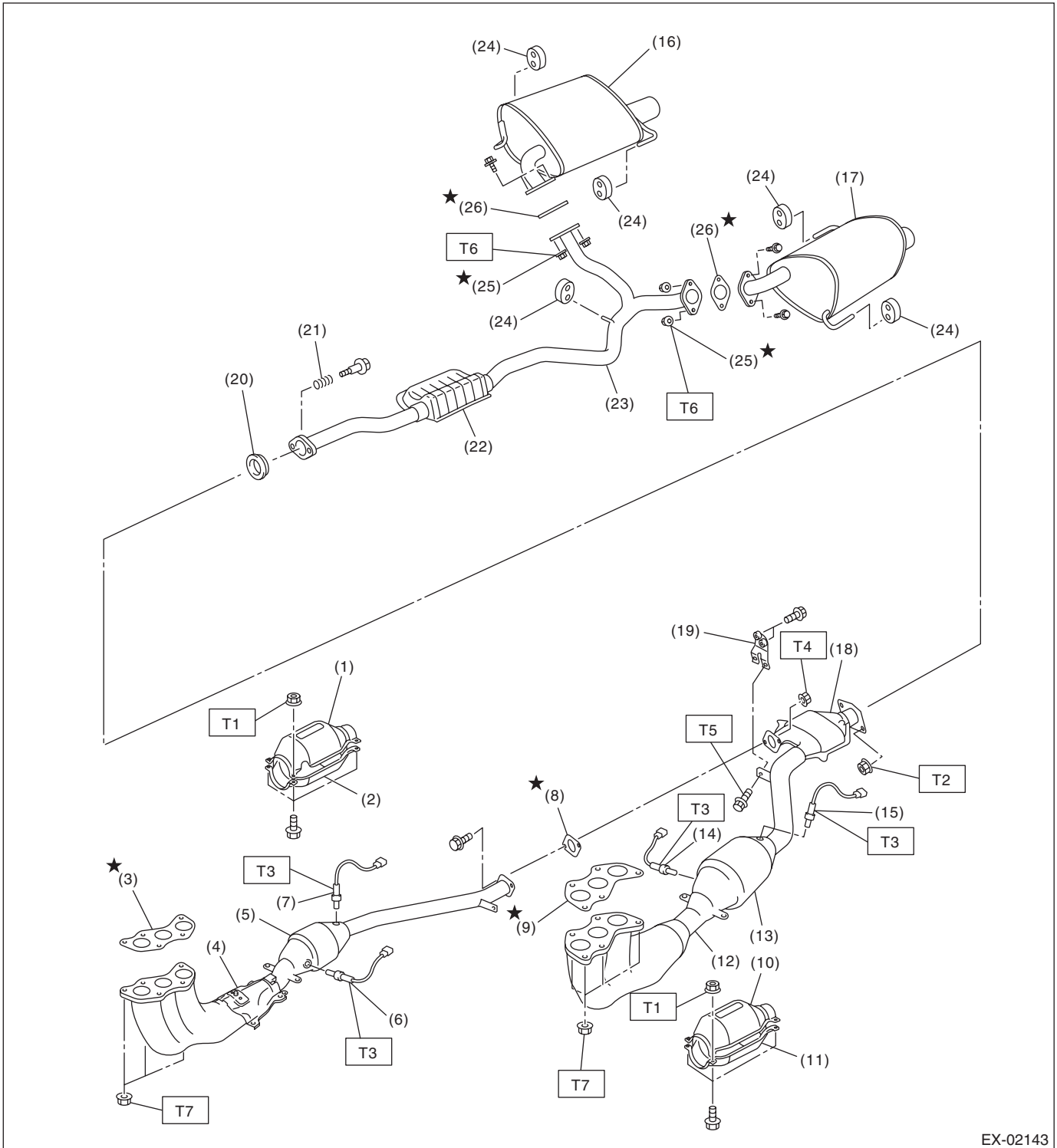

EX-02143

General Description

EXHAUST

(1) Front catalytic converter upper cover (RH)	(11) Front catalytic converter lower cover (LH)	(23) Rear exhaust pipe
(2) Front catalytic converter lower cover (RH)	(12) Front exhaust pipe (LH)	(24) Cushion rubber
(3) Gasket	(13) Front catalytic converter (LH)	(25) Self-locking nut
(4) Front exhaust pipe (RH)	(14) Front oxygen (A/F) sensor (LH)	(26) Gasket
(5) Front catalytic converter (RH)	(15) Rear oxygen sensor (LH)	
(6) Front oxygen (A/F) sensor (RH)	(16) Muffler (RH)	
(7) Rear oxygen sensor (RH)	(17) Muffler (LH)	
(8) Gasket	(18) Rear catalytic converter	
(9) Gasket	(19) Bracket	
(10) Front catalytic converter upper cover (LH)	(20) Gasket	
	(21) Spring	
	(22) Chamber	

Tightening torque: N·m (kgf·m, ft·lb)

T1: 13 (1.3, 9.4)

T2: 18 (1.8, 13.0)

T3: 21 (2.1, 15.2)

T4: 30 (3.1, 22.4)

T5: 35 (3.6, 26.0)

T6: 48 (4.9, 35.4)

T7: 70 (7.1, 51.6)

B: CAUTION

- Wear appropriate work clothing, including a cap, protective goggles and protective shoes when performing any work.
- Remove contamination including dirt and corrosion before removal, installation or disassembly.
- Keep the disassembled parts in order and protect them from dust and dirt.
- Before removal, installation or disassembly, be sure to clarify the failure. Avoid unnecessary removal, installation, disassembly and replacement.
- Vehicle components are extremely hot after driving. Be wary of receiving burns from heated parts.
- Be sure to tighten fasteners including bolts and nuts to the specified torque.
- Place shop jacks or rigid racks at the specified points.
- Before disconnecting connectors of sensors or units, be sure to disconnect the ground cable from battery.