

Fuel Delivery, Return and Evaporation Lines

FUEL INJECTION (FUEL SYSTEMS)

29. Fuel Delivery, Return and Evaporation Lines

A: REMOVAL

- 1) Set the vehicle on a lift.
- 2) Release the fuel pressure. <Ref. to FU(H6DO)-38, RELEASING OF FUEL PRESSURE, PROCEDURE, Fuel.>
- 3) Open the fuel filler flap lid, and remove the fuel filler cap.
- 4) Remove the floor mat. <Ref. to EI-70, REMOVAL, Floor Mat.>
- 5) Disconnect the fuel delivery pipes and hoses, and then disconnect the fuel return pipes and hoses, evaporation pipes and hoses.

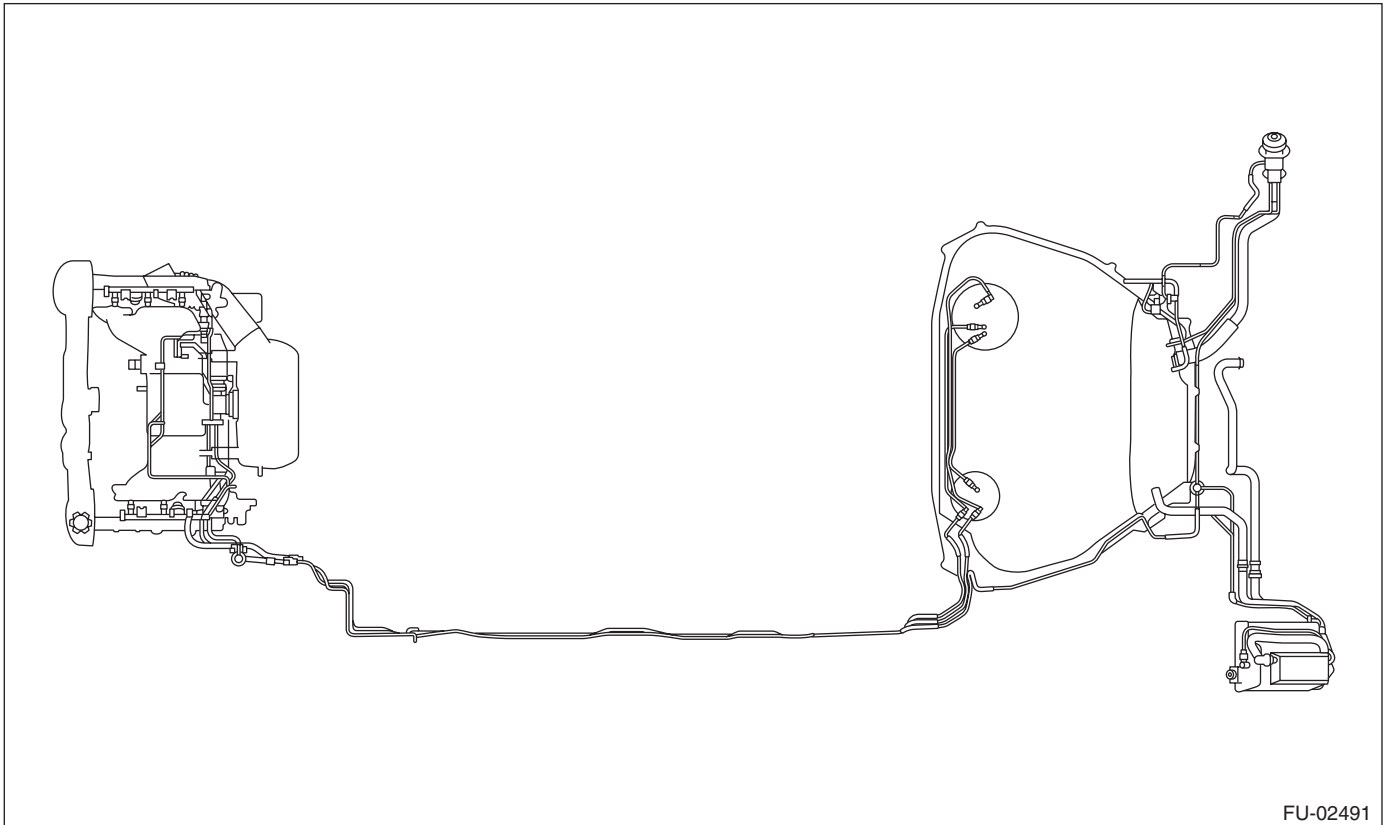

6) In the engine compartment, disconnect the fuel delivery hoses and evaporation hose.

- (1) Disconnect the quick connector on the fuel delivery line and return line by pushing the ST in the direction of the arrow.

ST 42099AE000 CONNECTOR REMOVER

- (2) Remove the clip and disconnect the evaporation hose from the pipe.

WARNING:

- Be careful not to spill fuel.
- Catch the fuel from hoses using a container or cloth.

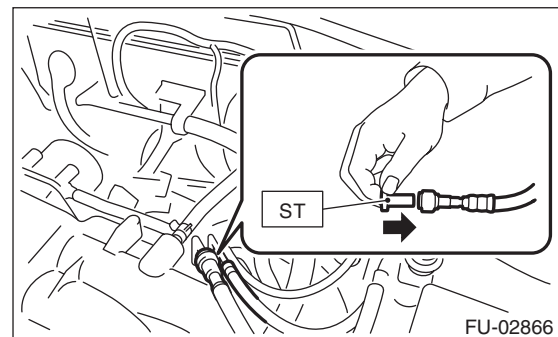

- (A) Fuel delivery hose
- (B) Return hose
- (C) Evaporation hose

- 7) Lift-up the vehicle.
- 8) Remove the fuel tank. <Ref. to FU(H6DO)-39, REMOVAL, Fuel Tank.>
- 9) Separate the quick connector of fuel line.
 - (1) Clean the pipe and connector, if they are covered with dust.
 - (2) To prevent from damaging or entering foreign matter, wrap the pipes and connectors with plastic bag etc.

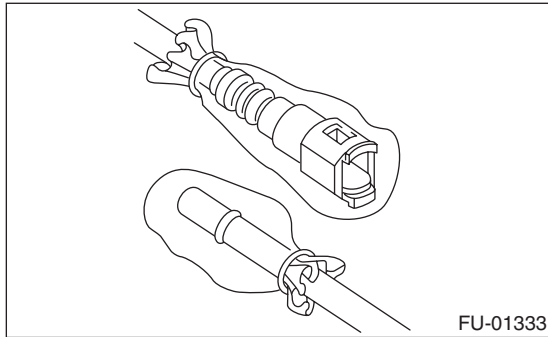

- (3) Hold the connector (A) and push the retainer (B) down.
- (4) Pull out the connector (A) from the retainer (B).

CAUTION:
If the retainer remains on the pipe side when the quick connector is disconnected, replace the retainer with a new part.

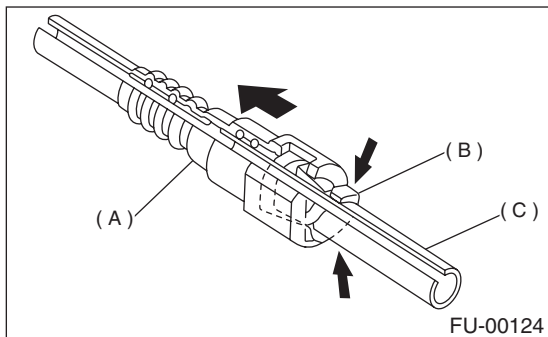

- (A) Connector
- (B) Retainer
- (C) Pipe

B: INSTALLATION

- 1) Connect the quick connector on fuel line.

CAUTION:

- If the retainer remains on the pipe side when the quick connector is disconnected, replace the retainer with a new part.
- Make sure there are no damage or dust on connections. If necessary, clean seal surface of pipe.

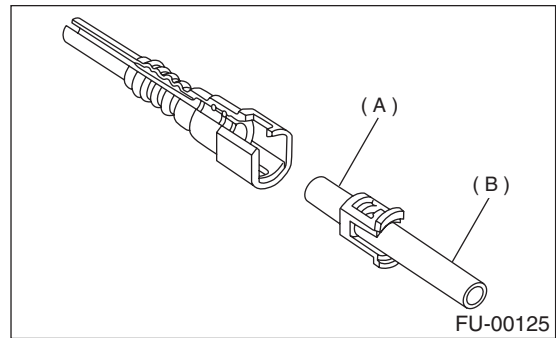

- (A) Seal surface
- (B) Pipe

- (1) Set the new retainer (B) to connector (A).
- (2) Push the pipe into the connector completely.

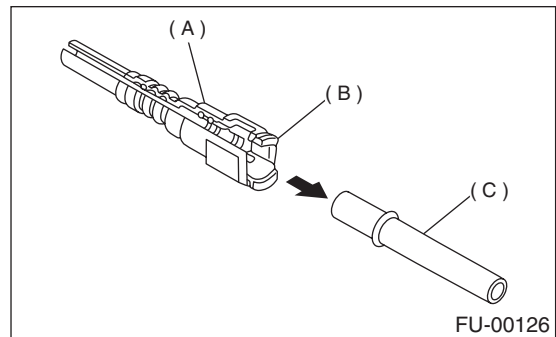

- (A) Connector
- (B) Retainer
- (C) Pipe

Fuel Delivery, Return and Evaporation Lines

FUEL INJECTION (FUEL SYSTEMS)

CAUTION:

- Pull the connector to ensure it is connected securely.
- Make sure the two retainer pawls are engaged in their mating positions in the connector.
- Be sure to inspect hoses and their connections for any leakage of fuel.

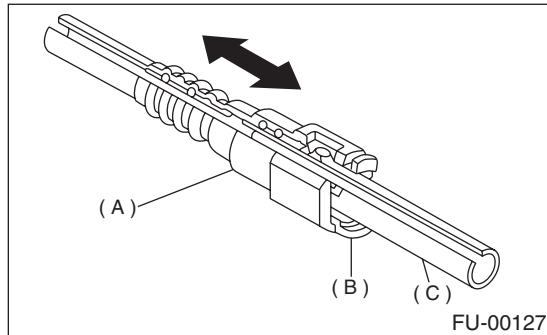

- (A) Connector
- (B) Retainer
- (C) Pipe

2) Connect the fuel delivery hose and return hose to the pipe with an overlap of 20 to 25 mm (0.79 to 0.98 in).

Type A: When the amount to be inserted is specified.

Type B: When the amount to be inserted is not specified.

$$\varnothing: 2.5 \pm 1.5 \text{ mm } (0.098 \pm 0.059 \text{ in})$$

$$L: 22.5 \pm 2.5 \text{ mm } (0.886 \pm 0.098 \text{ in})$$

CAUTION:

Be sure to inspect hoses and their connections for any leakage of fuel.

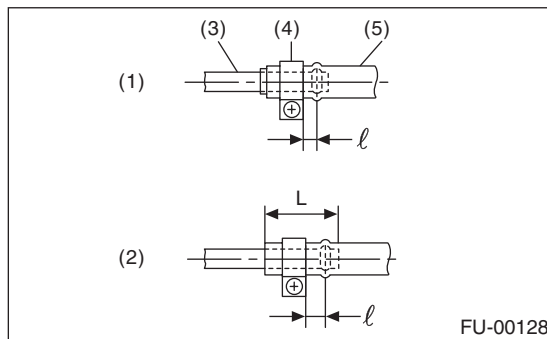

- (1) Type A
- (2) Type B
- (3) Pipe
- (4) Clamp
- (5) Hose

3) Connect the evaporation hose to the pipe with an overlap of 15 to 20 mm (0.59 to 0.79 in).

$$L = 17.5 \pm 2.5 \text{ mm } (0.689 \pm 0.098 \text{ in})$$

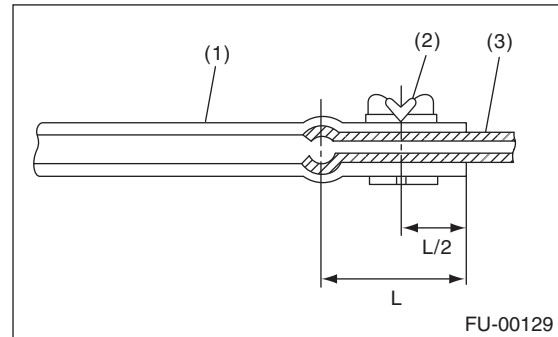

- (1) Hose
- (2) Clip
- (3) Pipe

C: INSPECTION

1) Make sure that there are no cracks on the fuel pipes and fuel hoses.

2) Make sure the fuel pipe and fuel hose connections are tightened firmly.