

4. Air Intake Chamber

A: REMOVAL

- 1) Remove the collector cover.
- 2) Loosen the clamp (A) which connects air intake chamber to throttle body.
- 3) Loosen the clamp (B) which connects intake duct to air intake chamber.
- 4) Remove the bolt (C) which secures air intake chamber to the stay.

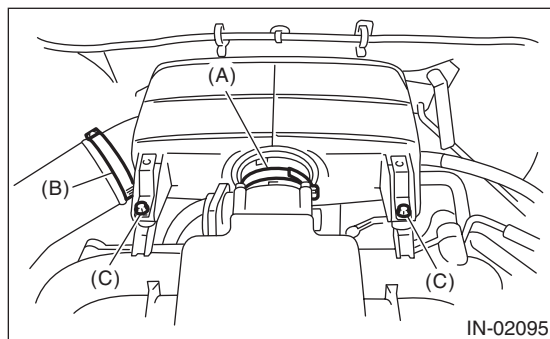

- 5) Disconnect the blow-by hoses, then remove the air intake chamber.

B: INSTALLATION

Install in the reverse order of removal.

Tightening torque:

Clamp (A), (B)

3.0 N·m (0.3 kgf-m, 2.2 ft-lb)

Bolt (C)

6.4 N·m (0.65 kgf-m, 4.7 ft-lb)

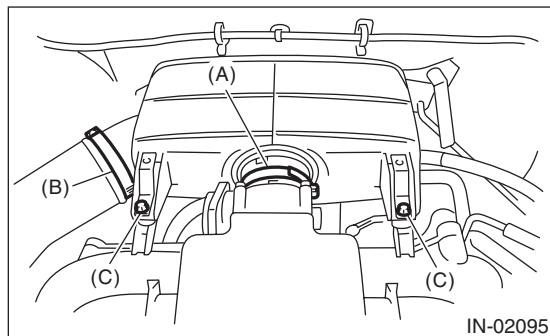

C: INSPECTION

- 1) Check for cracks or loose connections.
- 2) Check that no foreign matter is mixed in air intake chamber.