

5. Oil Pump Relief Valve

A: REMOVAL

1. REAR CHAIN COVER SIDE

Oil pump relief valve is integrated into oil pump cover as one unit; therefore, refer to "Oil Pump" for removal procedure. <Ref. to LU(H6DO)-8, REMOVAL, Oil Pump.>

2. OIL PAN UPPER SIDE

1) Remove the oil pan. <Ref. to LU(H6DO)-12, REMOVAL, Oil Pan and Strainer.>

2) Remove the plug, relief valve spring and relief valve.

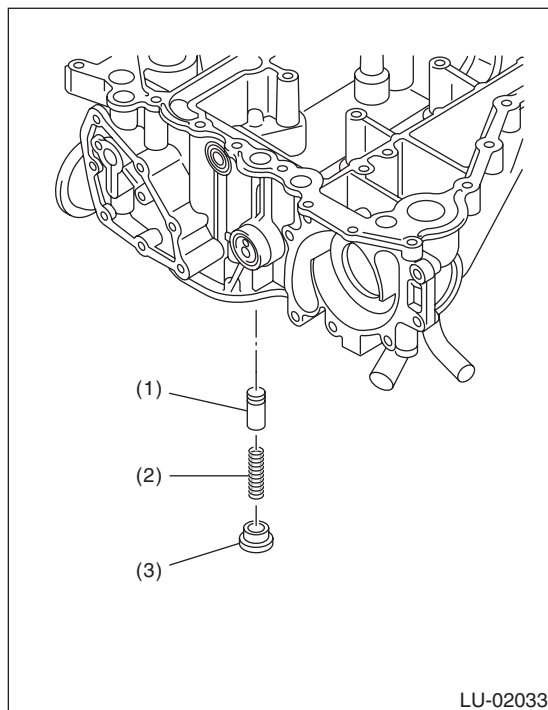

- (1) Relief valve
- (2) Relief valve spring
- (3) Plug

B: INSTALLATION

1. REAR CHAIN COVER SIDE

Oil pump relief valve is integrated into oil pump cover as one unit; therefore, refer to "Oil Pump" for installation procedure. <Ref. to LU(H6DO)-8, INSTALLATION, Oil Pump.>

2. OIL PAN UPPER SIDE

1) Install the relief valve, relief valve spring and plug.

NOTE:

Apply engine oil to the relief valve.

Tightening torque:

T: 44 N·m (4.5 kgf-m, 33 ft-lb)

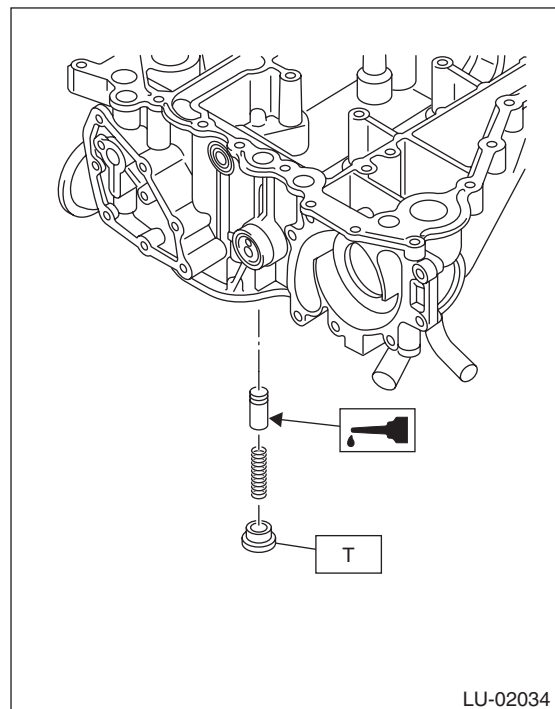

2) Install the oil pan. <Ref. to LU(H6DO)-12, INSTALLATION, Oil Pan and Strainer.>

C: INSPECTION

Check the worn shaft hole of oil pump relief valve case, clogged oil passage, crank and other parts for faults.