

Oil Pan and Strainer

LUBRICATION

6. Oil Pan and Strainer

A: REMOVAL

NOTE:

Before removing the oil pan upper, remove the engine from vehicle. <Ref. to ME(H6DO)-33, REMOVAL, Engine Assembly.> <Ref. to ME(H6DO)-62, REMOVAL, Cylinder Block.>

- 1) Set the vehicle on a lift.
- 2) Lift-up the vehicle.
- 3) Remove the under cover.
- 4) Drain the engine oil. <Ref. to LU(H6DO)-7, REPLACEMENT, Engine Oil.>
- 5) Insert the oil pan cutter blade between oil pan upper and oil pan lower.

CAUTION:

Do not use a screwdriver or similar tool in place of oil pan cutter.

- 6) Remove the oil pan lower.

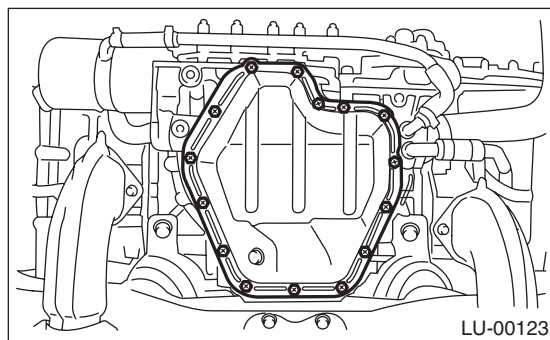

- 7) Remove the oil strainer.

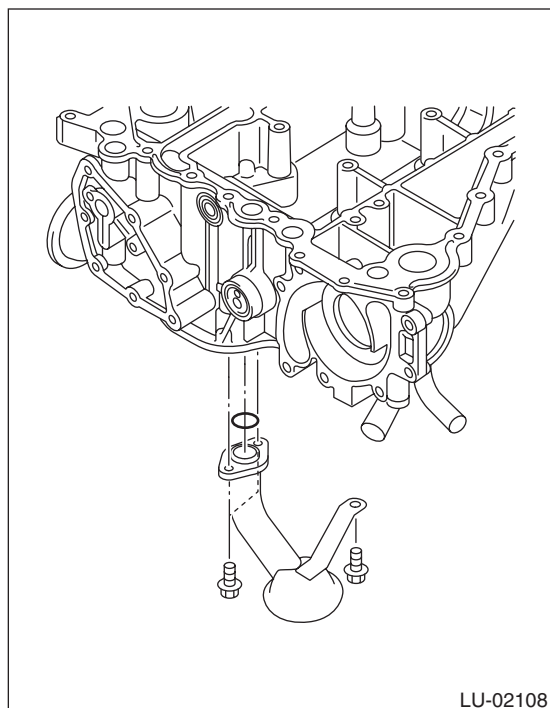

B: INSTALLATION

CAUTION:

Before installing the oil pan, wipe clean the mating surface of oil pan lower and oil pan upper.

- 1) Install the oil strainer onto oil pan upper.

NOTE:

Replace O-ring with a new part.

Tightening torque:

6.4 N·m (0.65 kgf·m, 4.7 ft·lb)

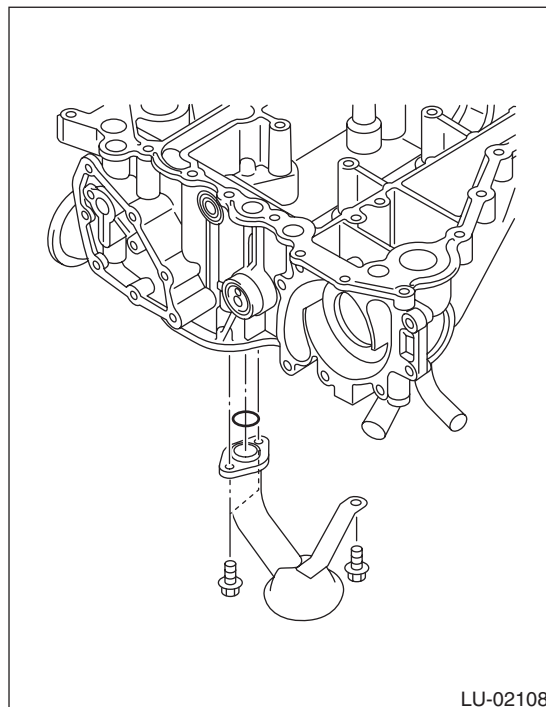

- 2) Apply liquid gasket to the mating surfaces, and install the oil pan.

Liquid gasket

THREE BOND 1280B (Part No. K0877YA018)

Applying liquid gasket diameter

5.0±1.0 mm (0.197±0.039 in)

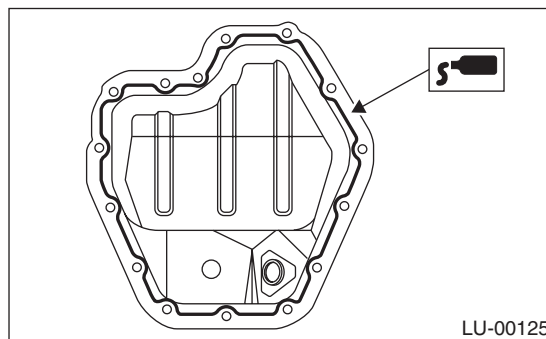

3) Tighten the oil pan lower installing bolts in the numerical order as shown in the figure.

Tightening torque:

6.4 N·m (0.65 kgf·m, 4.7 ft·lb)

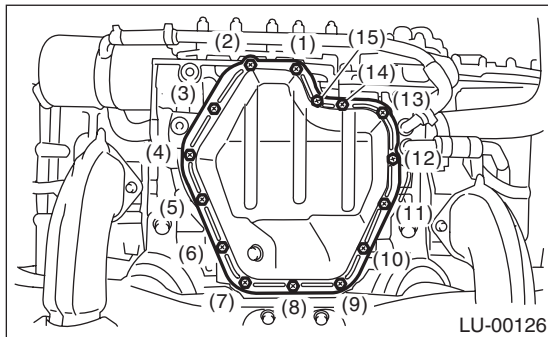

4) Install the under cover.

5) Refill the engine oil. <Ref. to LU(H6DO)-7, INSPECTION, Engine Oil.>

C: INSPECTION

Visually check that the oil pan, oil strainer and oil strainer stay are not damaged.