

## 16. Cam Sprocket

### A: REMOVAL

- 1) Remove the crank pulley. <Ref. to ME(H6DO)-41, REMOVAL, Crank Pulley.>
- 2) Remove the front chain cover. <Ref. to ME(H6DO)-42, REMOVAL, Front Chain Cover.>
- 3) Remove the timing chain assembly. <Ref. to ME(H6DO)-44, REMOVAL, Timing Chain Assembly.>
- 4) Remove the cam sprocket. To lock the camshaft, use the ST.

ST 499977500 CAM SPROCKET WRENCH

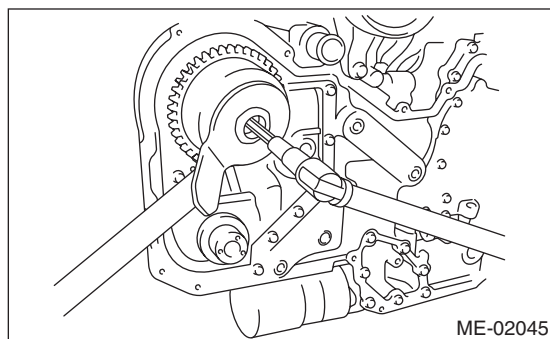

ST 18231AA020 CAM SPROCKET WRENCH

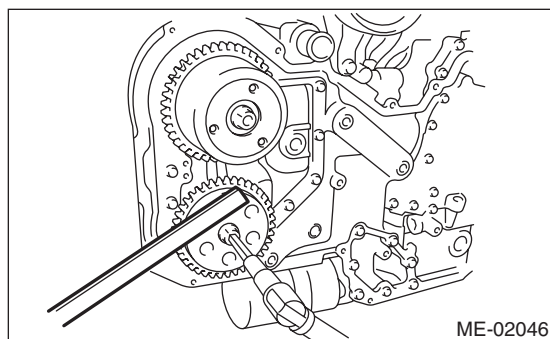

### B: INSTALLATION

- 1) Install the cam sprocket. To lock the camshaft, use the ST.

#### **Tightening torque:**

**29.5 N·m (3.0 kgf·m, 21.8 ft·lb)**

- 2) Further tighten the bolt.

#### **Tightening angle:**

**Intake**

**45°±5°**

**Exhaust**

**25°±5°**

ST 499977500 CAM SPROCKET WRENCH

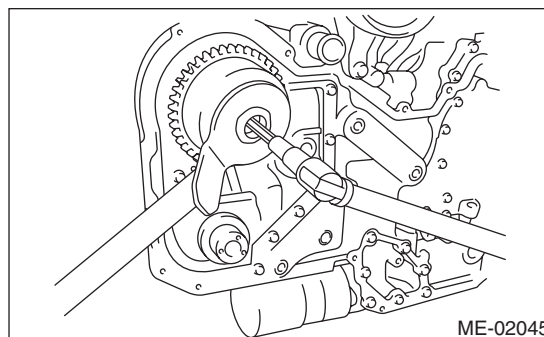

ST 18231AA020 CAM SPROCKET WRENCH

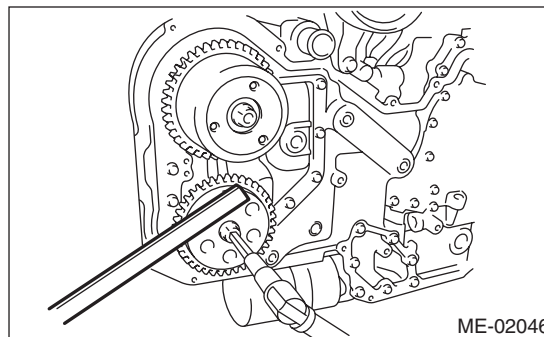

- 3) Install the timing chain assembly. <Ref. to ME(H6DO)-45, INSTALLATION, Timing Chain Assembly.>
- 4) Install the front chain cover. <Ref. to ME(H6DO)-42, INSTALLATION, Front Chain Cover.>
- 5) Install the crank pulley. <Ref. to ME(H6DO)-41, INSTALLATION, Crank Pulley.>

### C: INSPECTION

- 1) Check the cam sprocket teeth for abnormal wear and scratches.
- 2) Make sure there is no free play between cam sprocket and key.