

## 19. Camshaft

### A: REMOVAL

- 1) Remove the crank pulley. <Ref. to ME(H6DO)-41, REMOVAL, Crank Pulley.>
- 2) Remove the front chain cover. <Ref. to ME(H6DO)-42, REMOVAL, Front Chain Cover.>
- 3) Remove the timing chain assembly. <Ref. to ME(H6DO)-44, REMOVAL, Timing Chain Assembly.>
- 4) Remove the cam sprocket. <Ref. to ME(H6DO)-49, REMOVAL, Cam Sprocket.>
- 5) Remove the crank sprocket. <Ref. to ME(H6DO)-50, REMOVAL, Crank Sprocket.>
- 6) Remove the rear chain cover. <Ref. to ME(H6DO)-51, REMOVAL, Rear Chain Cover.>
- 7) Disconnect the oil pipe.

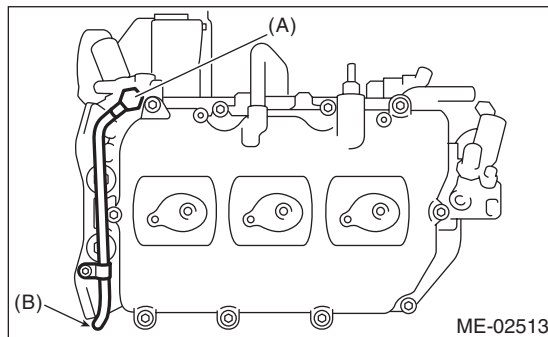

- (A) Bolt without filter (with protrusion)
- (B) Bolt with filter (without protrusion)

- 8) Remove the rocker cover (LH).

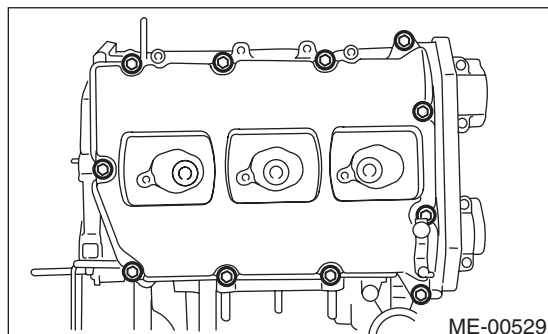

- 9) Remove the plugs (LH).

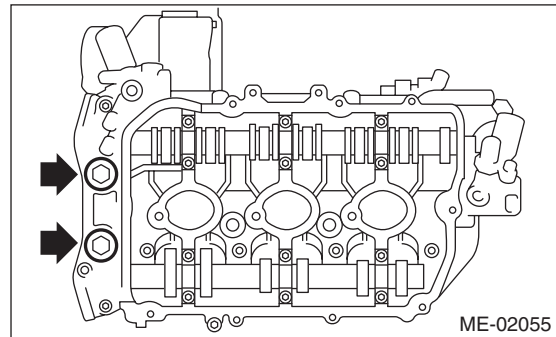

- 10) Loosen the camshaft cap bolts equally, a little at a time in alphabetical sequence shown in the figure.

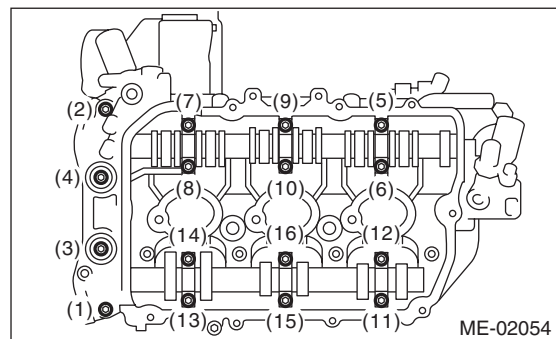

- 11) Remove the camshaft caps and camshaft (LH).

#### NOTE:

Arrange camshaft caps in order so that they can be installed in their original positions.

- 12) Similarly, remove the camshafts (RH) and related parts.

# Camshaft

## MECHANICAL

### B: INSTALLATION

- 1) Apply engine oil to camshaft journals, and install the camshaft.
- 2) Install the camshaft cap.
  - (1) Apply liquid gasket sparingly to back side of front camshaft cap as shown in the figure.

#### CAUTION:

Do not apply liquid gasket excessively. Applying excessively may cause excess gasket to flow toward cam journal, resulting in engine seizure.

#### Liquid gasket:

**THREE BOND 1280B (Part No. K0877YA018)**

#### Applying liquid gasket diameter:

**$2.0 \pm 0.5$  mm ( $0.079 \pm 0.020$  in)**

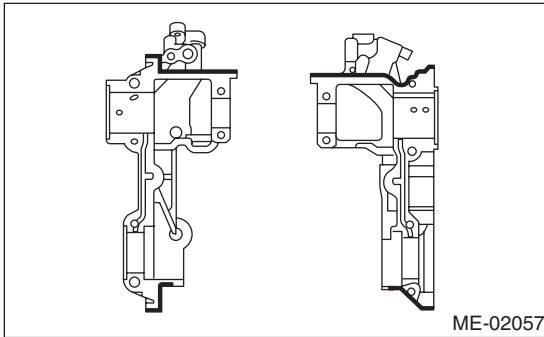

- (2) Apply engine oil to cap bearing surface, and install the cap to camshaft.
- (3) Tighten the rocker cover bolts in the numerical order as shown in the figure.

#### Tightening torque:

**(1) — (12): 16 N·m (1.6 kgf·m, 12 ft·lb)**

**(13) — (16): 9.75 N·m (1.0 kgf·m, 7.2 ft·lb)**

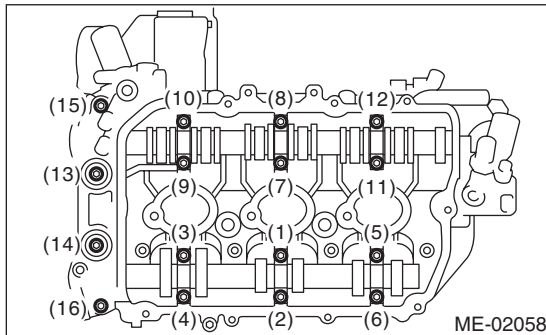

- 3) Install the plugs.

#### Tightening torque:

**60 N·m (6.1 kgf·m, 44 ft·lb)**

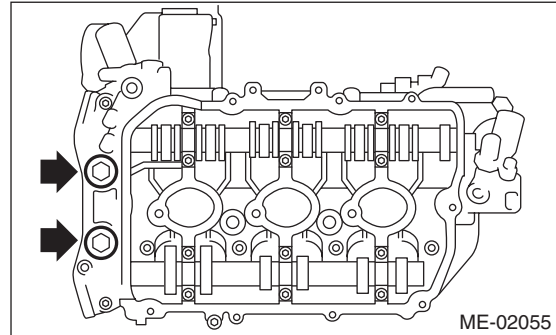

- 4) Install the rocker cover.

- (1) Apply liquid gasket sparingly to the mating surface of cylinder head and rocker cover as shown in the figure.

#### CAUTION:

Do not apply liquid gasket excessively. Applying excessively may cause excess gasket to flow toward cam journal, resulting in engine seizure.

#### Liquid gasket:

**THREE BOND 1280B (Part No. K0877YA018)**

- LH side

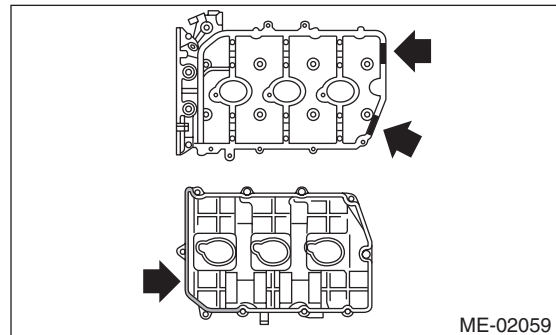

- RH side

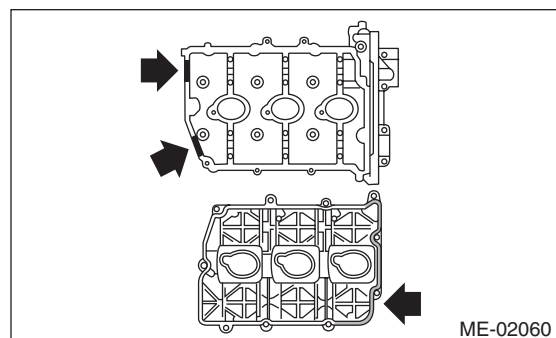

(2) Tighten the rocker cover bolts in the numerical order as shown in the figure.

**Tightening torque:**

**6.4 N·m (0.65 kgf·m, 4.7 ft·lb)**

- LH side

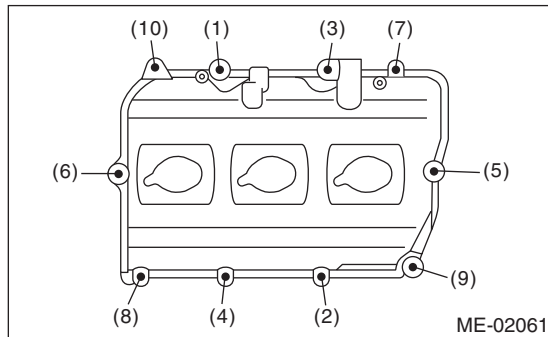

- RH side

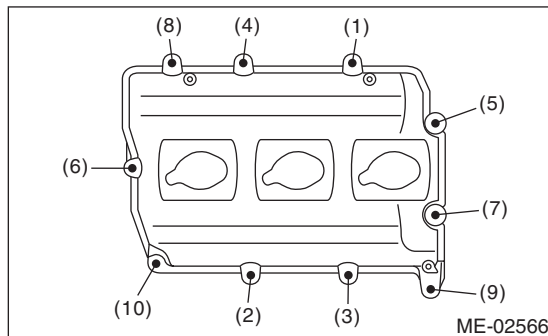

5) Connect the oil pipe.

**CAUTION:**

- Be careful not to mistake the location of (A) and (B).
- Be sure to use a new gasket.

**Tightening torque:**

(A), (B)

**29 N·m (3.0 kgf·m, 21.4 ft·lb)**

(C)

**6.4 N·m (0.65 kgf·m, 4.7 ft·lb)**

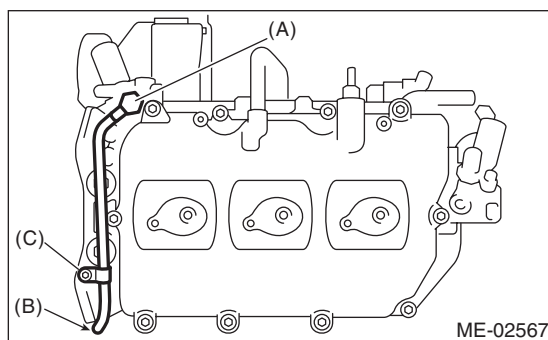

- (A) Bolt without filter (with protrusion)
- (B) Bolt with filter (without protrusion)
- (C) Oil pipe bolt

6) Install the rear chain cover. <Ref. to ME(H6DO)-51, INSTALLATION, Rear Chain Cover.>

7) Install the crank sprocket.

<Ref. to ME(H6DO)-50, INSTALLATION, Crank Sprocket.>

8) Install the cam sprocket.

<Ref. to ME(H6DO)-49, INSTALLATION, Cam Sprocket.>

9) Install the timing chain assembly.

<Ref. to ME(H6DO)-45, INSTALLATION, Timing Chain Assembly.>

10) Install the front chain cover.

<Ref. to ME(H6DO)-42, INSTALLATION, Front Chain Cover.>

11) Install the crank pulley.

<Ref. to ME(H6DO)-41, INSTALLATION, Crank Pulley.>

**C: INSPECTION**

1) Measure the bend of camshaft. Repair or replace if bended.

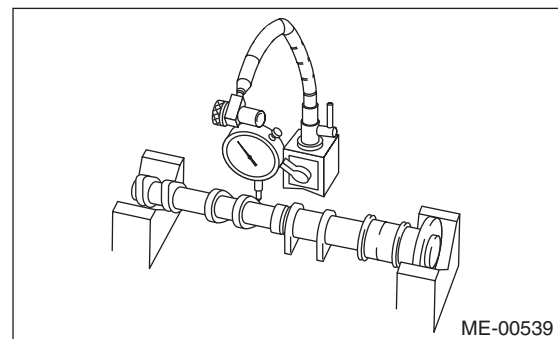

2) Check the journal for damage and wear. Replace if faulty.

3) Measure the outside diameter of camshaft journal. If the journal diameter is not within specification, check the oil clearance.

	Camshaft journal	
	Front	Except for front
Standard value	37.946 — 37.963	25.946 — 25.963
mm (in)	(1.4939 — 1.4946)	(1.0215 — 1.0222)

4) Measurement of the camshaft journal oil clearance:

- (1) Clean the bearing caps and camshaft journals.
- (2) Place the camshafts on cylinder head. (Without installing the valve rocker.)
- (3) Place a plastigauge across each camshaft journals.
- (4) Install the bearing cap.

**NOTE:**

Do not turn the camshaft.

- (5) Remove the bearing caps.

# Camshaft

## MECHANICAL

(6) Measure the widest point of the plastigauge on each journal. If oil clearance exceeds the standard, replace the camshaft. If necessary, replace the camshaft caps and cylinder head as a set.

### **Standard:**

**0.037 — 0.072 mm (0.0015 — 0.0028 in)**

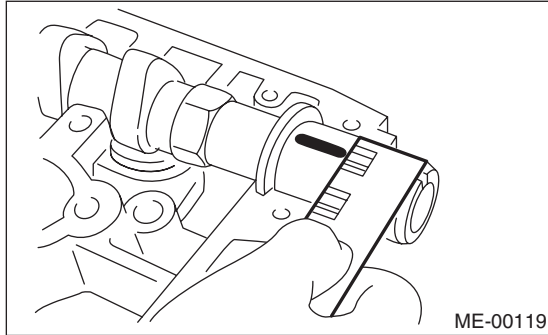

(7) Completely remove the plastigauge.

5) Check the cam face condition; remove the minor faults by grinding with oil stone. Measure the cam height H. If it exceeds the standard or offset wear occurs, replace it.

### **Cam height H:**

#### **Standard**

##### **Intake**

**HIGH 42.09 — 42.19 mm (1.6571 — 1.6610 in)**

**LOW1 38.14 — 38.24 mm (1.5016 — 1.5055 in)**

**LOW2 34.94 — 35.04 mm (1.3756 — 1.3795 in)**

##### **Exhaust**

**41.65 — 41.75 mm (1.6398 — 1.6437 in)**

### **Cam base circle diameter A:**

#### **Intake**

**HIGH 32.0 mm (1.2598 in)**

**LOW1 31.84 mm (1.2535 in)**

**LOW2 31.84 mm (1.2535 in)**

#### **Exhaust**

**32.0 mm (1.2598 in)**

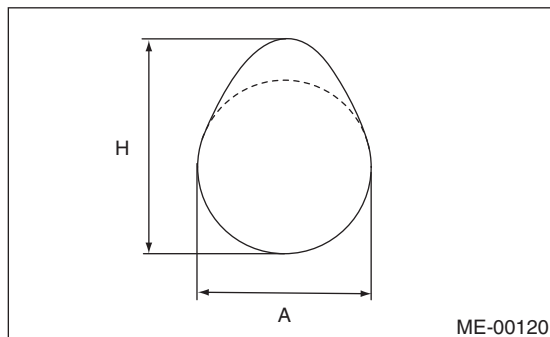

6) Measure the side clearance of the camshaft with a dial gauge. If the side clearance exceeds the standard or there is offset wear, replace the caps and cylinder head as a set. If necessary replace the camshaft.

### **Standard**

#### **Intake**

**0.075 — 0.135 mm (0.0030 — 0.0053 in)**

#### **Exhaust**

**0.030 — 0.090 mm (0.0012 — 0.0035 in)**