

22.ATF Cooler Pipe and Hose

A: REMOVAL

- 1) Set the vehicle on a lift.
- 2) Remove the battery.
- 3) Lift-up the vehicle.
- 4) Remove the under cover.
- 5) Remove the radiator under cover.

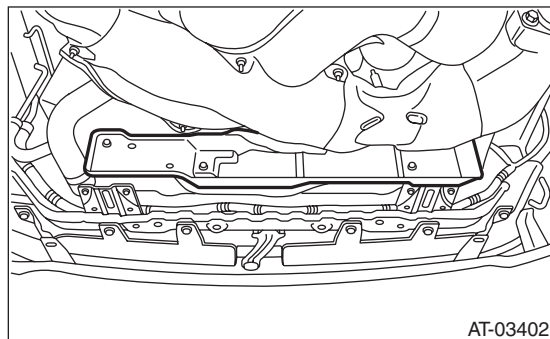

- 6) Disconnect the ATF cooler hose from the radiator.

NOTE:

- Do not use a screwdriver or other pointed tools.
- If it is hard to remove the hose, wrap the hose with cloth to prevent from damaging it, and while turning with pliers, pull straight out by hand.

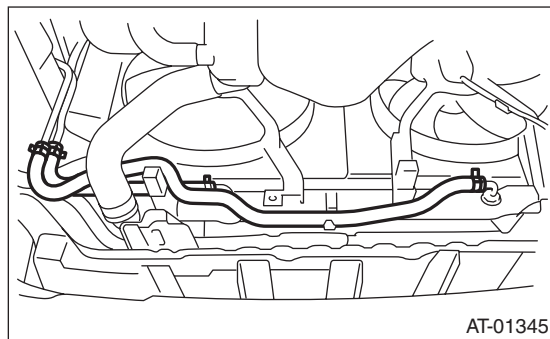

- 7) Disconnect the ATF cooler hoses from the pipes.

NOTE:

- Do not use a screwdriver or other pointed tools.
- If it is hard to remove the hose, wrap the hose with cloth to prevent from damaging it, and while turning with pliers, pull straight out by hand.

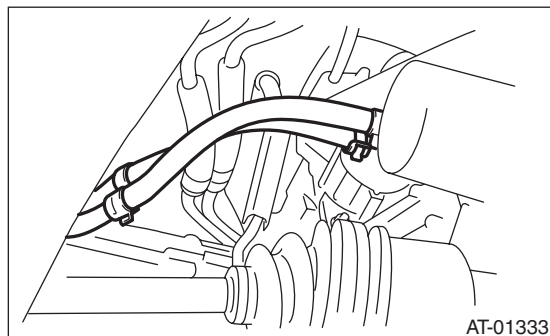

- 8) Disconnect the ATF cooler pipe from frame.

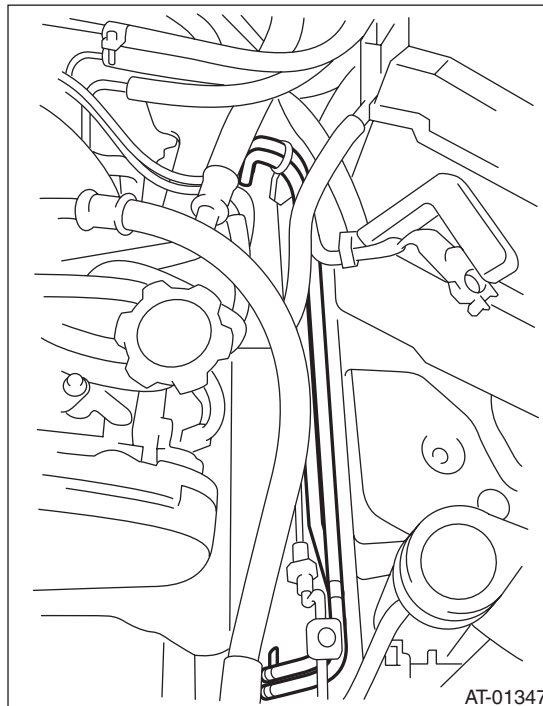

- 9) Remove the oil cooler inlet and outlet pipes.

NOTE:

When disconnecting the outlet pipe, be careful not to lose the ball and spring used with retaining screw.

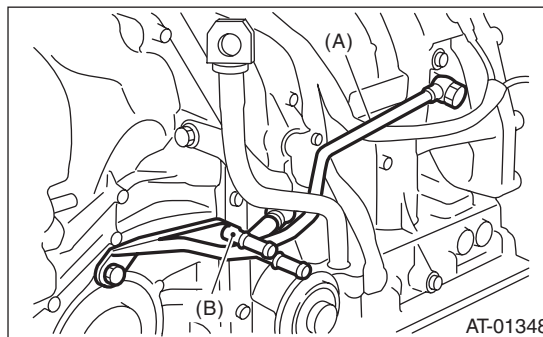

- (A) Inlet pipe
- (B) Outlet pipe

ATF Cooler Pipe and Hose

AUTOMATIC TRANSMISSION

B: INSTALLATION

1) Install the oil cooler inlet and outlet pipes with new washers.

Tightening torque:

T1: 25 N·m (2.5 kgf-m, 18 ft-lb)

T2: 40 N·m (4.1 kgf-m, 29.5 ft-lb)

T3: 44 N·m (4.5 kgf-m, 32.5 ft-lb)

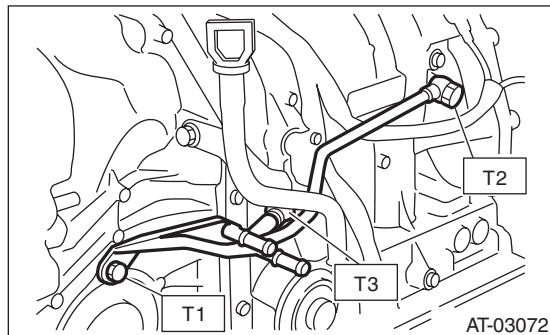

2) Install the ATF cooler pipe to frame.

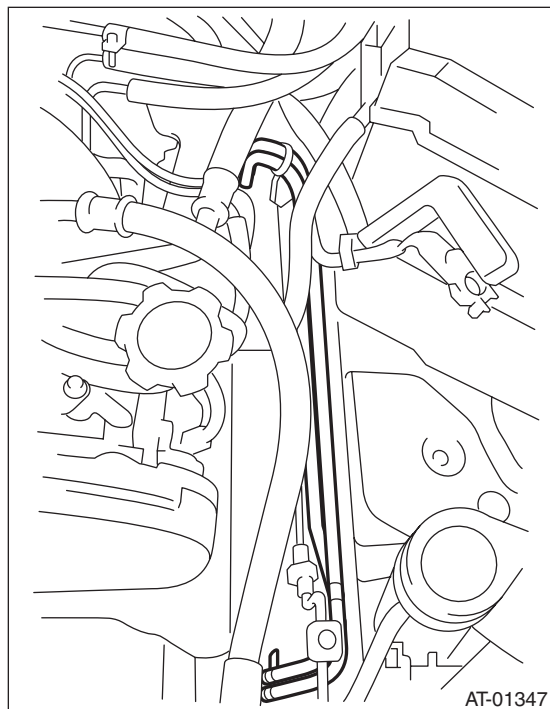

3) Connect the ATF cooler hose to the pipe on the transmission side.

NOTE:

- Install so that the hose is not folded over, excessively bent or twisted.
- Insert the hose to the specified position.

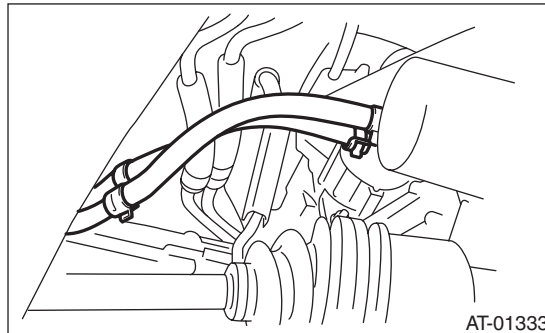

4) Connect the ATF cooler hose to the pipe on the radiator side.

NOTE:

- Install so that the hose is not folded over, excessively bent or twisted.
- Insert the hose to the specified position.

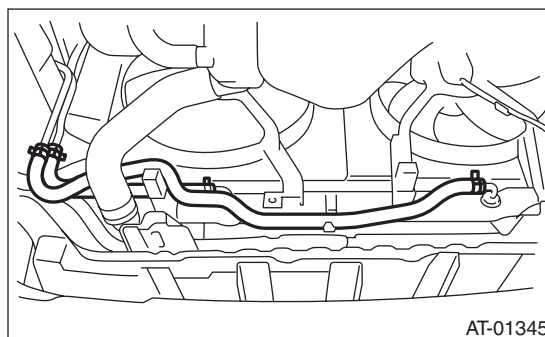

5) Install the radiator under cover.

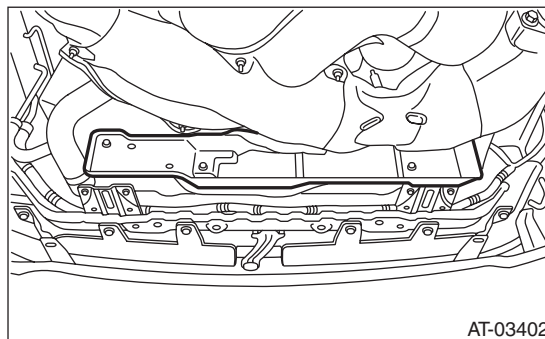

6) Install the under cover.

7) Install the battery.

8) Fill the ATF. <Ref. to 4AT-26, Automatic Transmission Fluid.>

NOTE:

Make sure there are no ATF leaks in joints between the transmission, radiator, pipes, and hoses.

C: INSPECTION

Repair or replace any faulty hoses, pipes, clamps, and washers found in the inspection below.

- 1) Check for ATF leaks in joints between the transmission, radiator, pipes, and hoses.
- 2) Check the clamp for deformation.
- 3) Lightly bend the hose and check for cracks in the surface or other damages.
- 4) Pinch the hose with your fingers and check for poor elasticity. Also check for poor elasticity in the parts where the clamp was installed by pressing with your fingernail.
- 5) Check for peeling, cracks, and deformation at the tip of the hose.