

35.AT Main Case

A: REMOVAL

- 1) Remove the transmission assembly from vehicle body. <Ref. to 4AT-35, REMOVAL, Automatic Transmission Assembly.>
- 2) Pull out the torque converter assembly. <Ref. to 4AT-68, REMOVAL, Torque Converter Assembly.>
- 3) Remove the input shaft.

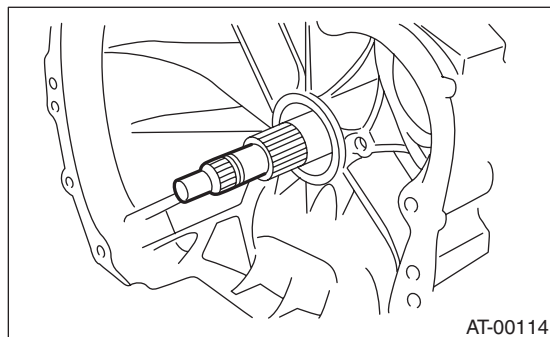

- 4) Lift-up the lever on the rear side of transmission harness connector, and then disconnect it from the stay.
- 5) Disconnect the inhibitor switch connector from the stay.
- 6) Disconnect the air breather hose.
- 7) Remove the oil charge pipe. <Ref. to 4AT-67, REMOVAL, Oil Charge Pipe.>
- 8) Remove the oil cooler inlet and outlet pipes. <Ref. to 4AT-63, REMOVAL, ATF Cooler Pipe and Hose.>
- 9) Separate the converter case from the transmission case. <Ref. to 4AT-81, REMOVAL, Converter Case.>
- 10) Remove the oil pump housing. <Ref. to 4AT-83, REMOVAL, Oil Pump Housing.>
- 11) Take out the high clutch, thrust needle bearing and reverse clutch assembly.

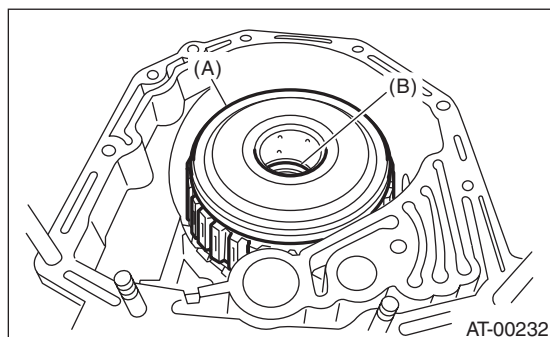

- (A) High clutch and reverse clutch ASSY
- (B) Thrust needle bearing

- 12) Take out the high clutch hub and thrust bearing.

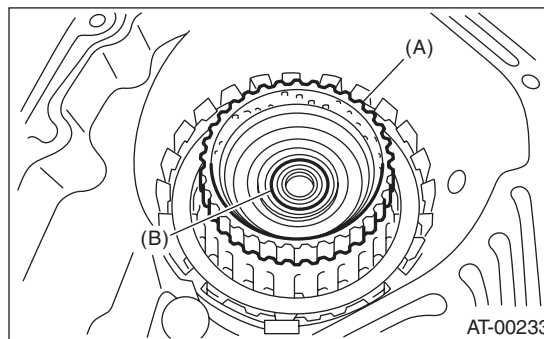

- (A) High clutch hub
- (B) Thrust needle bearing

- 13) Take out the front sun gear and thrust needle bearing.

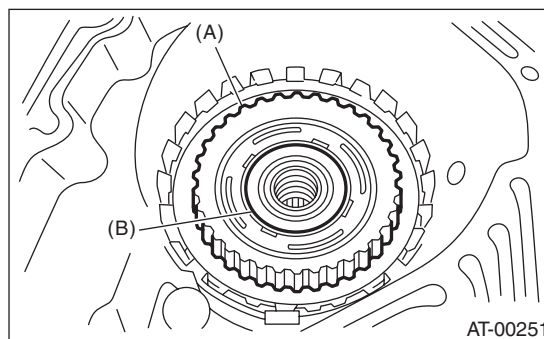

- (A) Front sun gear
- (B) Thrust needle bearing

- 14) Pull out the leaf spring, being careful not to break it.

NOTE:
Remove it while pressing down on the lower leaf spring.

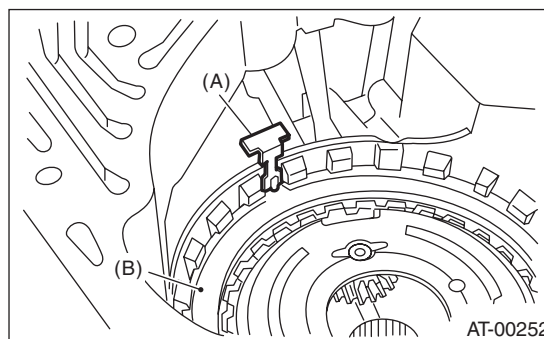

- (A) Leaf spring
- (B) Retaining plate

AT Main Case

AUTOMATIC TRANSMISSION

15) Remove the snap ring and thrust needle bearing.

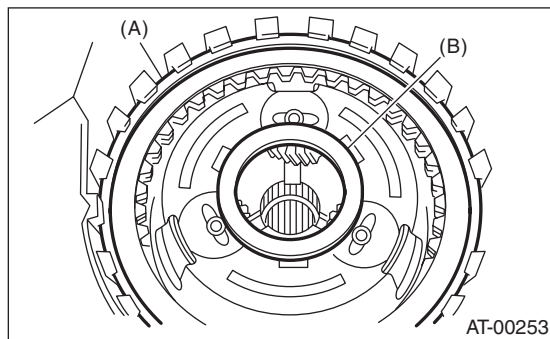

- (A) Snap ring
- (B) Thrust needle bearing

16) Take out the retaining plate, drive plate and driven plate of 2-4 brake.

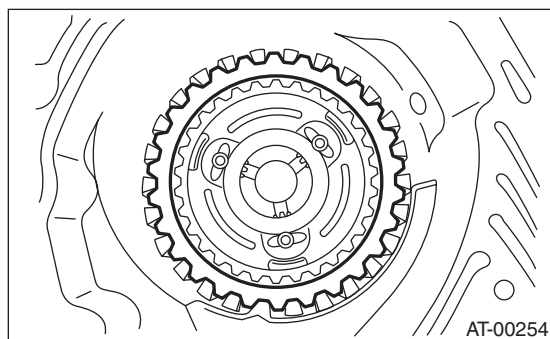

17) Take out the thrust needle bearing, planetary gear assembly and low clutch assembly.

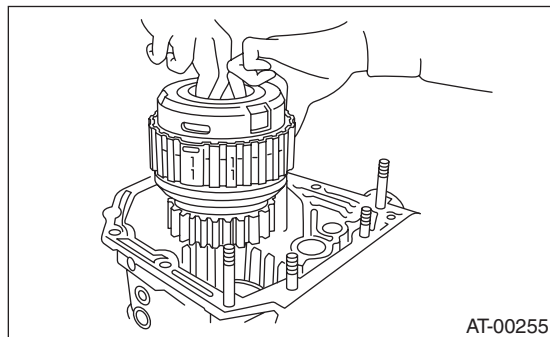

18) Remove the 2-4 brake seal.

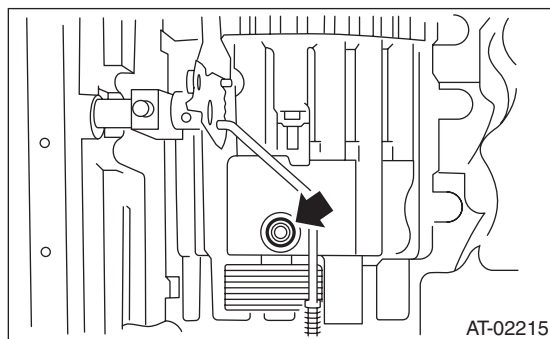

19) Remove the snap ring.

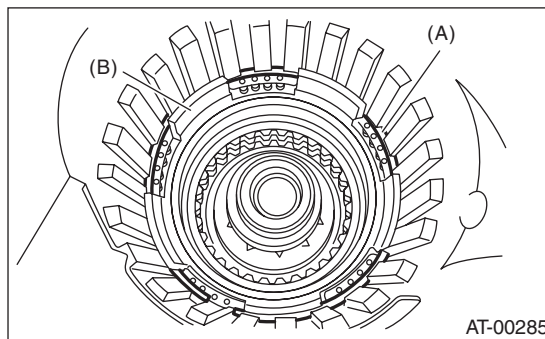

- (A) Snap ring
- (B) 2-4 brake piston

20) Take out the 2-4 brake return spring.

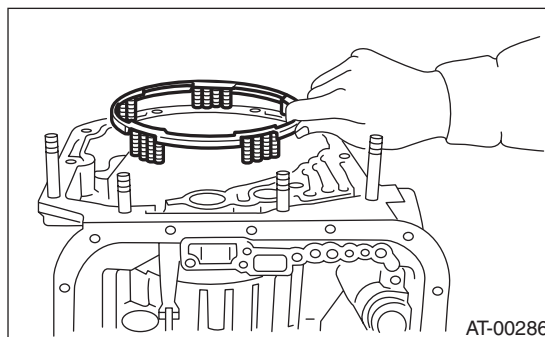

21) Remove the 2-4 brake piston and piston retainer while taking care not to damage them.

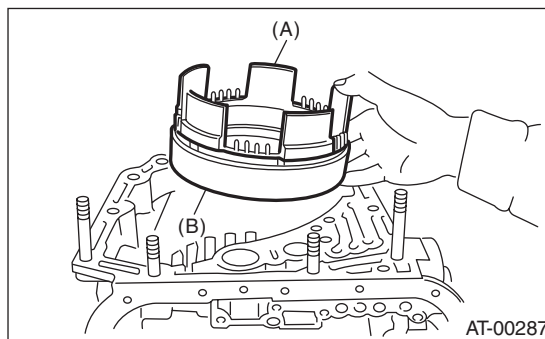

- (A) 2-4 brake piston
- (B) 2-4 brake piston retainer

22) Pull out the leaf spring without bending it.

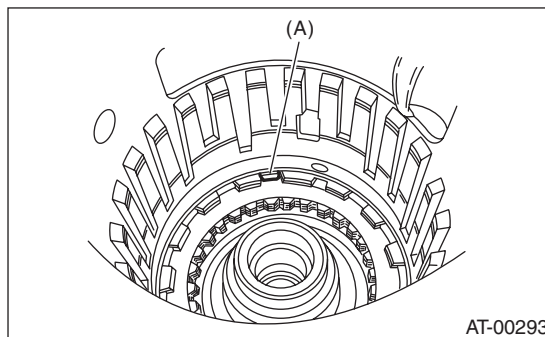

- (A) Leaf spring

23) Remove the snap ring.

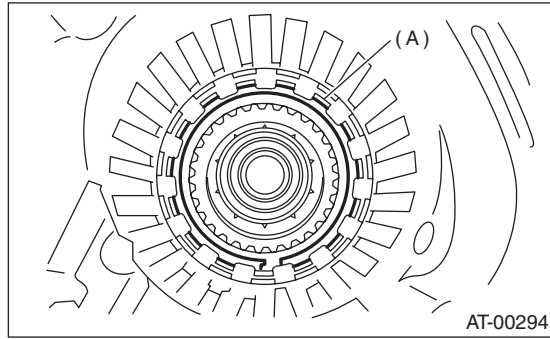

(A) Snap ring

24) Take out the retaining plate, drive plate, driven plate and dish plate.

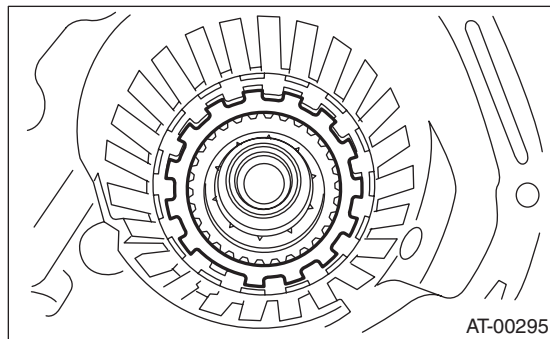

25) Turn the transmission case upside down, and then take out the socket bolts while holding the one-way clutch inner race by hand.

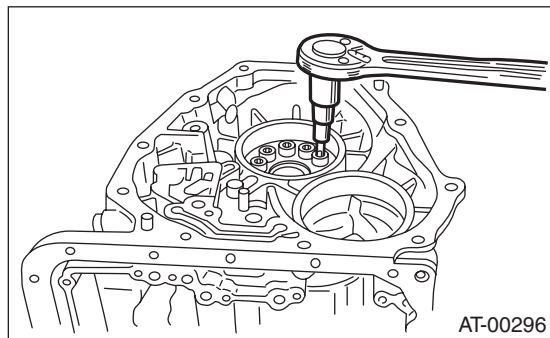

26) Remove the spring retainer.

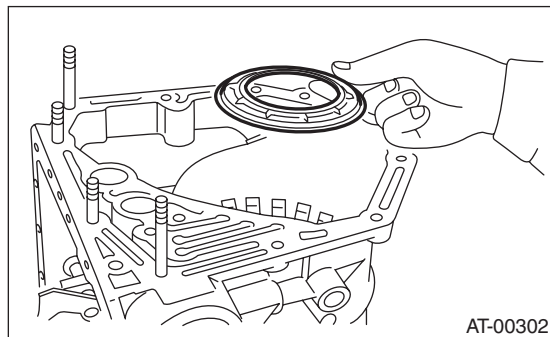

27) Take out the return spring.

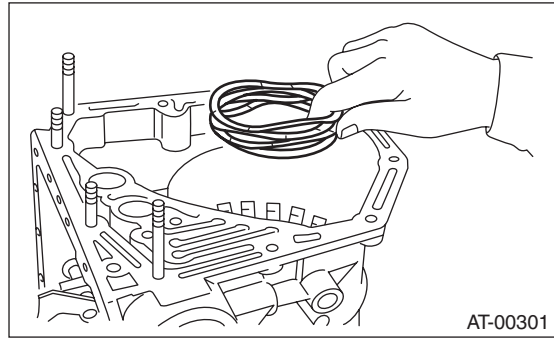

28) Apply compressed air.

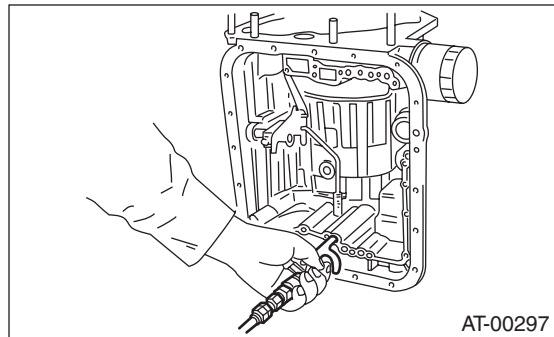

29) Take out the low & reverse piston.

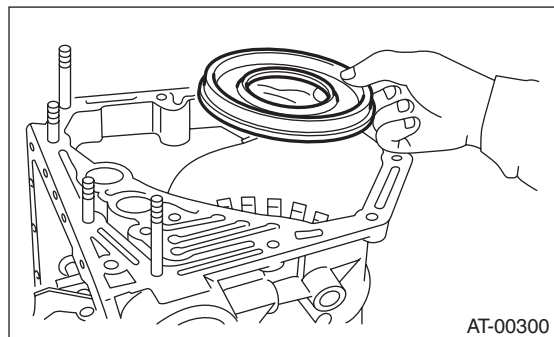

AT Main Case

AUTOMATIC TRANSMISSION

B: INSTALLATION

1) Install the low & reverse brake piston.

NOTE:

- Take care not to damage the lip seal.
- Apply ATF to the lip.

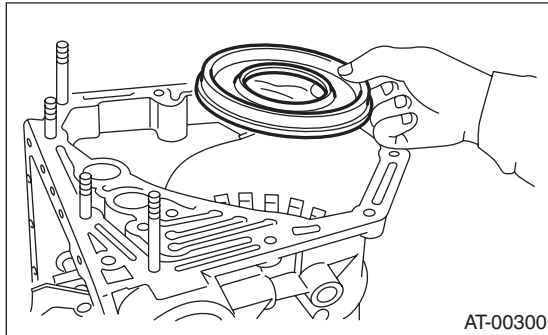

2) Install the return spring.

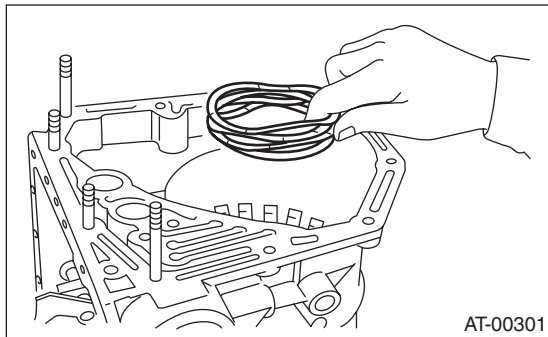

3) Install the spring retainer.

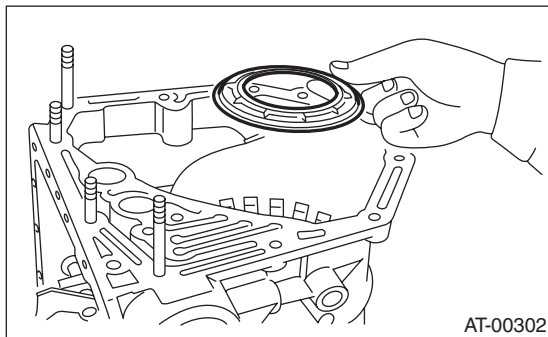

4) Install the one-way clutch inner race, spring retainer and return spring.

5) Tighten the socket head bolts evenly from the rear side of transmission case.

Tightening torque:

25 N·m (2.5 kgf·m, 18 ft·lb)

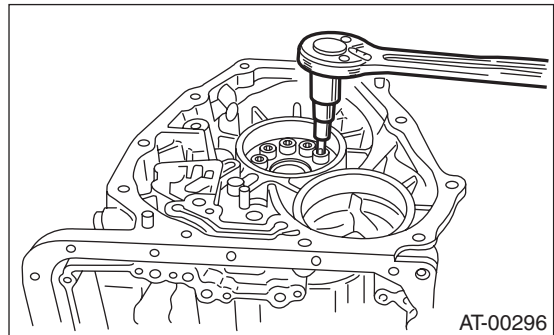

6) Place the front side of transmission body up.

7) Install the thrust needle bearing.

8) Place the dish plate, driven plate, drive plate and retaining plate neatly in this order on surface table.

9) Set the micro gauge to retaining plate, and read its scale.

NOTE:

The value, which is read in the gauge at this time, is zero point.

10) Scale and record the weight "Z" of a flat board which will be put on retaining plate.

NOTE:

- Use a stiff board which does not bend against load as a flat board to be put on retaining plate.

- Use a flat board of its weight less than 82 N (8.5 kgf, 18.7 lb).

11) Put the flat board on retaining plate.

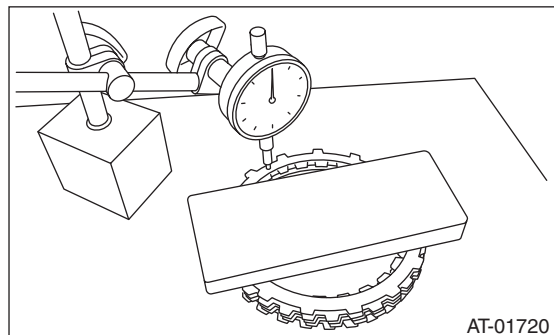

12) Using the following formula, read the push/pull gauge, and calculate "N".

$$N = 83 \text{ N (8.5 kgf, 18.7 lb)} - Z$$

N: Value indicated on push/pull gauge

83 N (8.5 kgf, 18.7 lb) : Load applied to clutch plate

Z: Flat board weight

13) Press the center of retaining plate by applying a force of N using push/pull gauge, and then measure and record the height A. Measure at three locations or more spaced by equal distances and take the average value.

NOTE:

If measuring in three locations, measure every 120°. If measuring in four locations, measure every 90°.

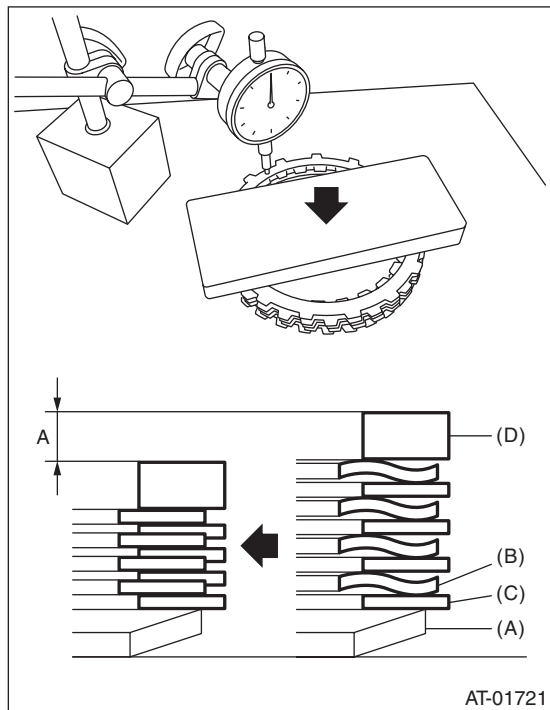

- (A) Dish plate
- (B) Driven plate
- (C) Drive plate
- (D) Retaining plate

14) Installation of the low & reverse brake:
Install the dish plate, driven plate, drive plate and retaining plate, and then secure them with a snap ring.

NOTE:

Pay attention to the orientation of the dish plate.

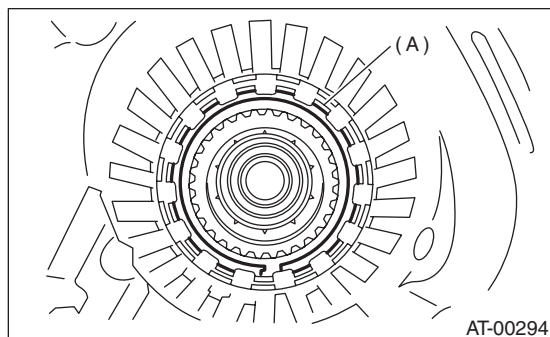

- (A) Snap ring

15) Apply compressed air intermittently to check for operation.

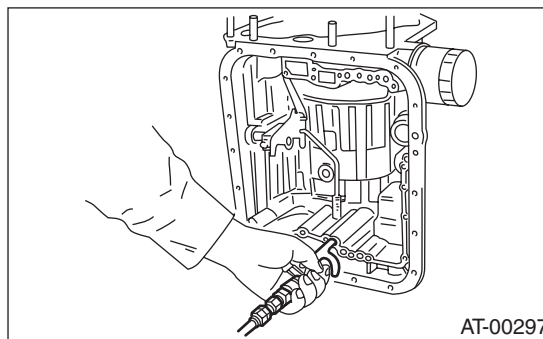

16) Place same thickness shims on both sides to prevent plate from tilting, then measure and record the clearance B.

NOTE:

Do not push in the shim down with force to a point where the waves on the drive plate will be crushed.

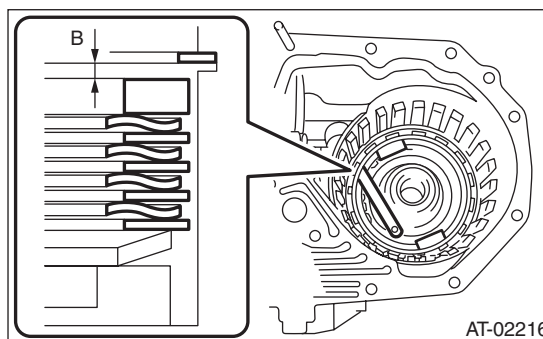

17) Piston stroke calculation

Calculate with A and B dimensions recorded before. If the calculated value exceeds the service limit, replace the drive plate with a new part and adjust it within the initial specification.

$$T = A + B$$

T: Piston stroke

A: Amount of drive plate compression

B: Clearance between retaining plate and snap ring

Initial standard:

2.15 — 2.65 mm (0.085 — 0.104 in)

Limit thickness:

2.95 mm (0.116 in)

Retaining plate	
Part number	Thickness mm (in)
31667AA420	3.8 (0.150)
31667AA320	4.1 (0.161)
31667AA330	4.4 (0.173)
31667AA340	4.7 (0.185)
31667AA350	5.0 (0.197)
31667AA360	5.3 (0.209)
31667AA370	5.6 (0.220)
31667AA380	5.9 (0.232)

AT Main Case

AUTOMATIC TRANSMISSION

18) Install the leaf spring of the low & reverse brake.

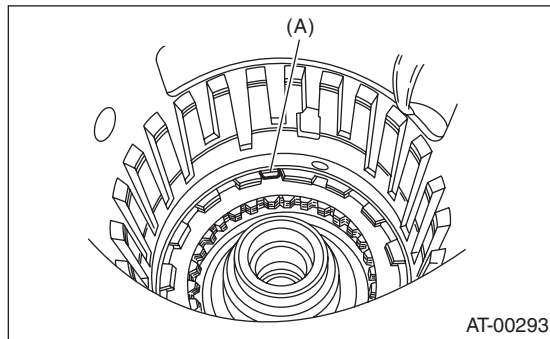

(A) Leaf spring

19) Install the 2-4 brake piston and 2-4 brake retainer by aligning the hole of the 2-4 brake retainer with the hole on the transmission case.

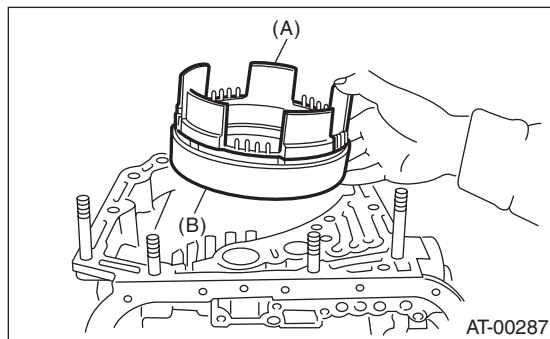

(A) 2-4 brake piston

(B) 2-4 brake piston retainer

20) Install 2-4 brake piston return spring to the transmission case.

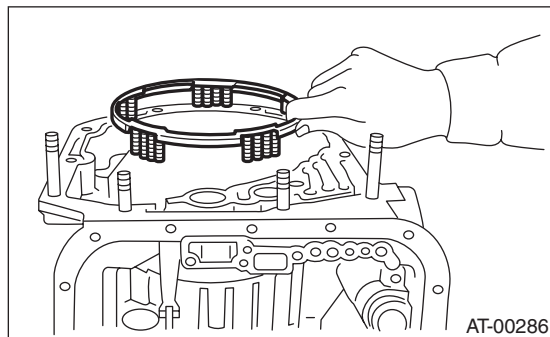

21) Position the snap ring in the transmission. Using ST, press the snap ring into the specified location.

ST 498677100 COMPRESSOR

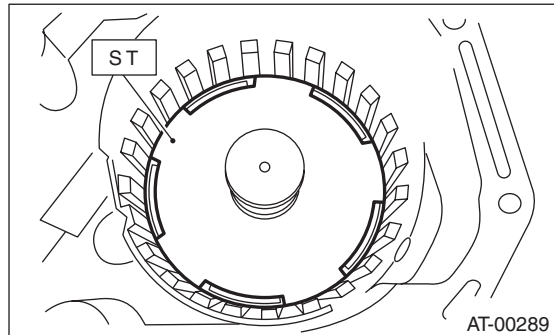

22) Install the planetary gear and low clutch assembly to the transmission case.

Install carefully while rotating the low clutch and planetary gear assembly slowly, paying special attention not to damage the seal ring.

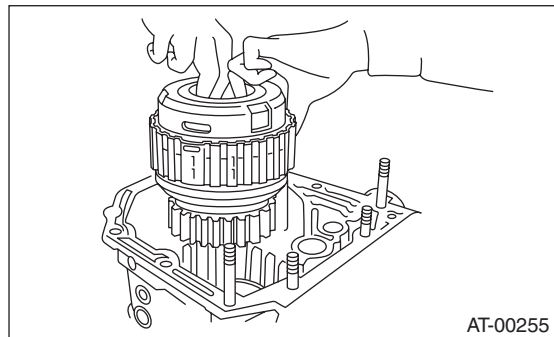

23) Place the dish plate, driven plate, drive plate and retaining plate neatly in this order on surface table.

24) Set the micro gauge to retaining plate, and read its scale.

NOTE:

The value, which is read in the gauge at this time, is zero point.

25) Scale and record the weight "Z" of a flat board which will be put on retaining plate.

NOTE:

- Use a stiff board which does not bend against load as a flat board to be put on retaining plate.

- Use a flat board weighing less than 100 N (10.2 kgf, 22.5 lb).

26) Put the flat board on retaining plate.

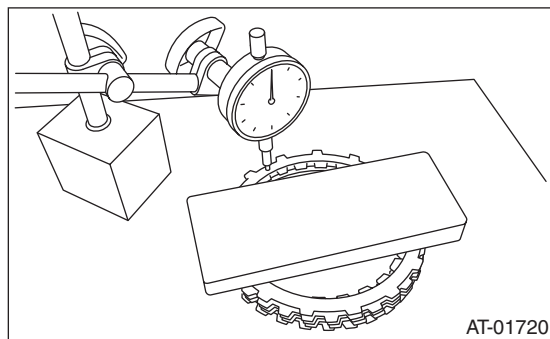

27) Using the following formula, read the push/pull gauge, and calculate "N".

$$N = 100 N (10.2 \text{ kgf}, 22.5 \text{ lb}) - Z$$

N: Value indicated on push/pull gauge

100 N (10.2 kgf, 22.5 lb) : Load applied to clutch plate

Z: Flat board weight

28) Press the center of retaining plate by applying a force of N using push/pull gauge, and then measure and record the height A. Measure at three locations or more spaced by equal distances and take the average value.

NOTE:

If measuring in three locations, measure every 120°. If measuring in four locations, measure every 90°.

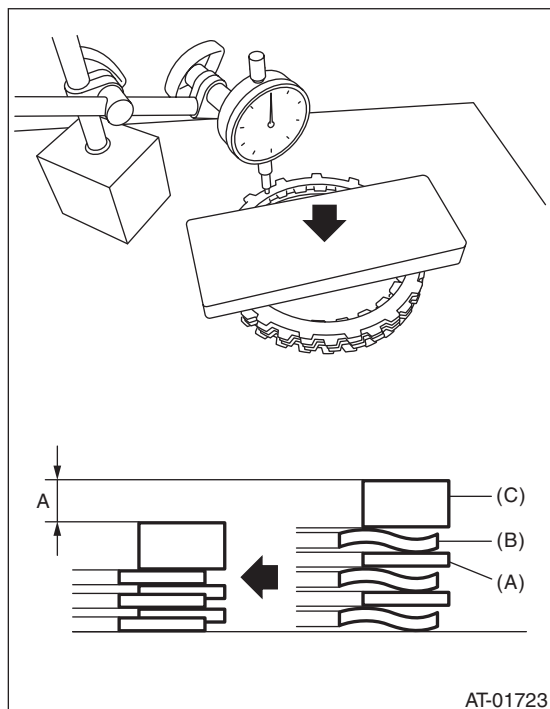

- (A) Driven plate
- (B) Drive plate
- (C) Retaining plate

29) Install the pressure plate, drive plate, driven plate, retaining plate and snap ring.

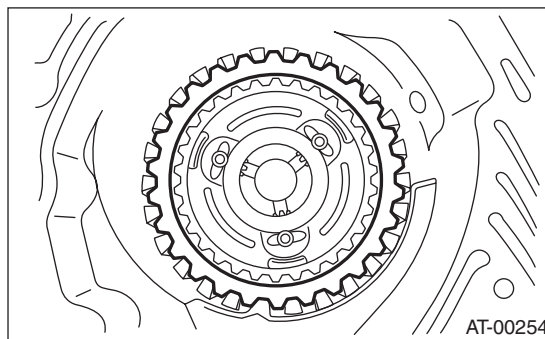

30) Install a new 2-4 brake oil seal to the transmission case.

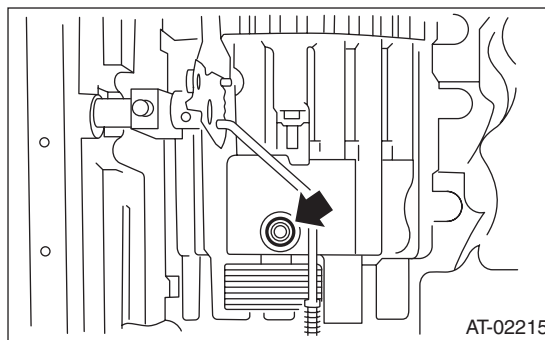

31) After all 2-4 brake component parts have been installed, blow in air intermittently and confirm the operation of the brake.

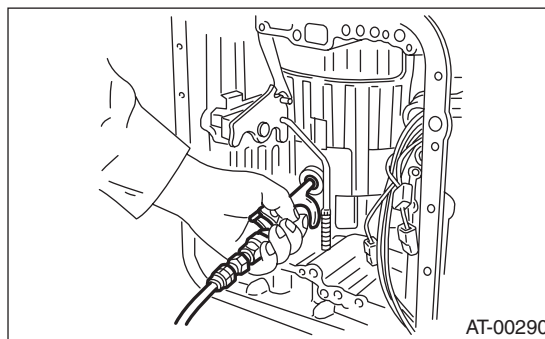

32) Measure the clearance B between the retaining plate and snap ring.

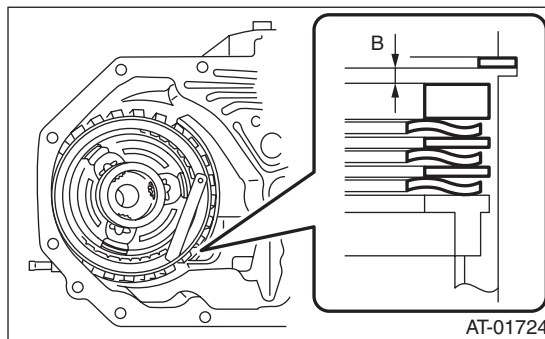

AT Main Case

AUTOMATIC TRANSMISSION

33) Piston stroke calculation

Calculate with A and B dimensions recorded before. If the calculated value exceeds the service limit, replace the drive plate with a new part and adjust it within the initial specification.

$$T = A + B$$

T: Piston stroke

A: Amount of drive plate compression

B: Clearance between retaining plate and snap ring

Initial standard:

1.7 — 2.1 mm (0.067 — 0.083 in)

Limit thickness:

2.3 mm (0.091 in)

Retaining plate	
Part number	Thickness mm (in)
31567AA991	5.6 (0.220)
31567AB001	5.8 (0.228)
31567AB011	6.0 (0.236)
31567AB021	6.2 (0.244)
31567AB031	6.4 (0.252)
31567AB041	6.6 (0.260)

34) Be careful not to mistake the location of the leaf spring to be installed.

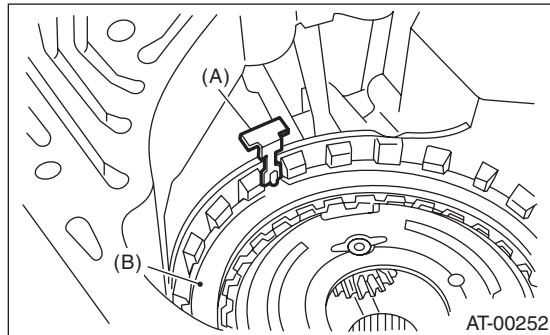

- (A) Leaf spring
- (B) Retaining plate

35) Install the thrust needle bearing in the correct direction.

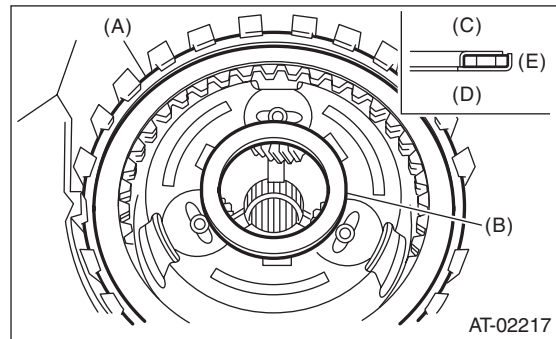

- (A) Snap ring
- (B) Thrust needle bearing
- (C) Upside
- (D) Downside
- (E) Outside

36) Install the front sun gear and the thrust needle bearing.

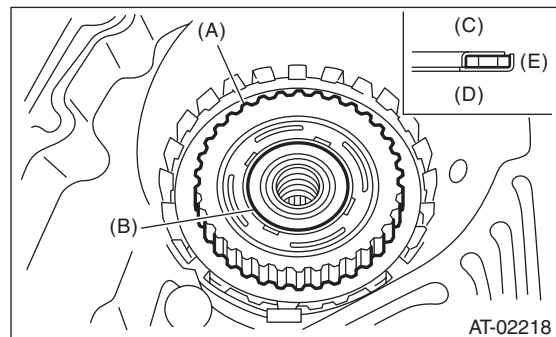

- (A) Front sun gear
- (B) Thrust needle bearing
- (C) Upside
- (D) Downside
- (E) Outside

37) Install the high clutch hub.

Attach the thrust needle bearing to hub using vaseline, and then install the hub by correctly engaging the splines of the front planetary carrier.

38) Install the thrust needle bearing in the proper direction.

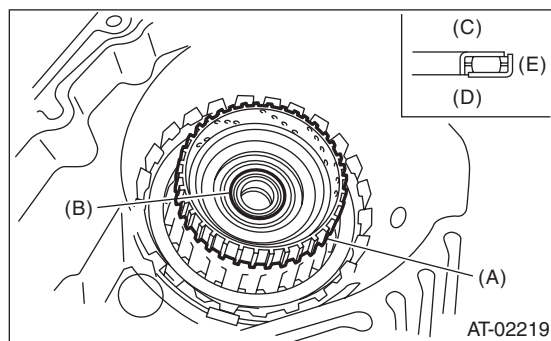

- (A) High clutch hub
- (B) Thrust needle bearing
- (C) Upside
- (D) Downside
- (E) Outside

39) Install the high clutch assembly.

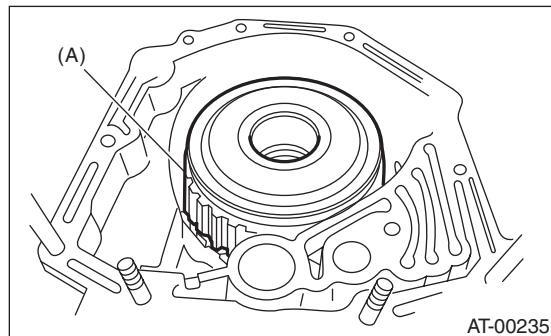

- (A) High clutch and reverse clutch ASSY

40) Adjust the total end play. <Ref. to 4AT-87, ADJUSTMENT, Oil Pump Housing.>

41) Install the thrust needle bearing in the proper direction.

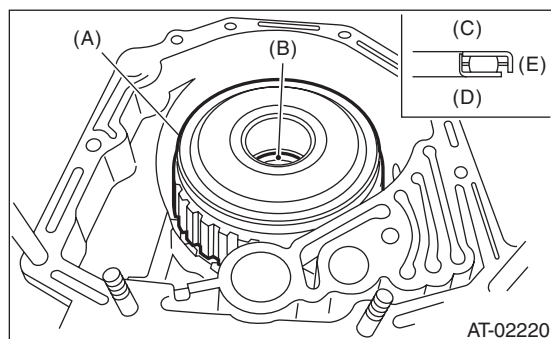

- (A) High clutch and reverse clutch ASSY
- (B) Thrust needle bearing
- (C) Upside
- (D) Downside
- (E) Outside

42) Install a new gasket along with the oil pump housing assembly. <Ref. to 4AT-83, INSPECTION, Oil Pump Housing.>

43) Install the converter case to the transmission case assembly. <Ref. to 4AT-81, INSTALLATION, Converter Case.>

44) Insert the inhibitor switch and transmission connector to the stay.

45) Install the air breather hose. <Ref. to 4AT-66, INSTALLATION, Air Breather Hose.>

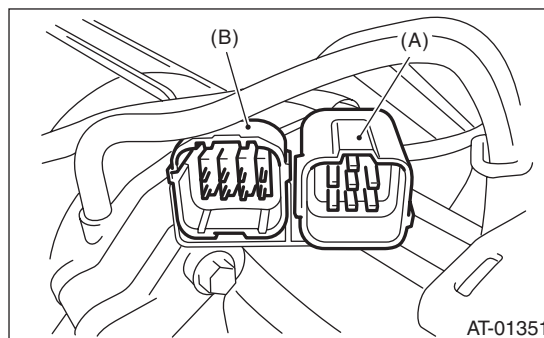

- (A) Transmission connector
- (B) Inhibitor switch connector

46) Install the oil cooler pipe. <Ref. to 4AT-64, INSTALLATION, ATF Cooler Pipe and Hose.>

47) Install the oil charge pipe together with an O-ring. <Ref. to 4AT-67, INSTALLATION, Oil Charge Pipe.>

48) Insert the input shaft while rotating it lightly by hand, and then check the amount of protrusion.

Normal protrusion A:

50 — 55 mm (1.97 — 2.17 in)

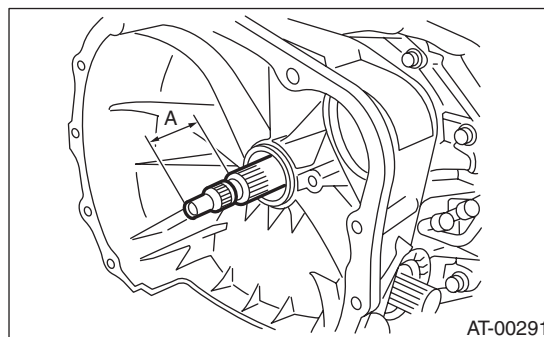

49) Install the torque converter assembly. <Ref. to 4AT-68, INSTALLATION, Torque Converter Assembly.>

50) Install the transmission assembly to the vehicle. <Ref. to 4AT-38, INSTALLATION, Automatic Transmission Assembly.>

AT Main Case

AUTOMATIC TRANSMISSION

C: DISASSEMBLY

1. HIGH CLUTCH AND REVERSE CLUTCH

1) Remove the snap ring, and then take out the retaining plate, drive plate and driven plate.

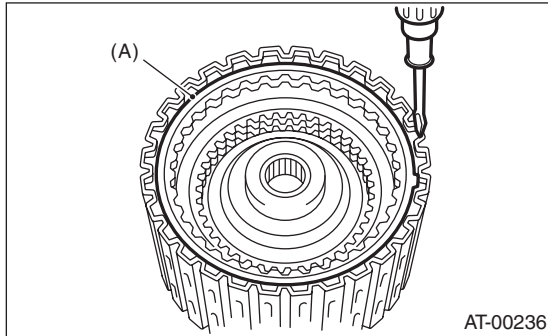

(A) Snap ring

2) Remove the snap ring, and then take out the retaining plate, drive plate and driven plate.

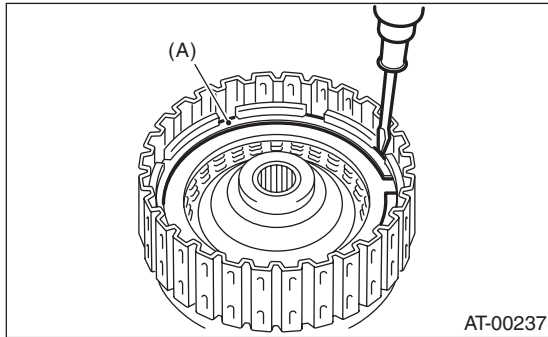

(A) Snap ring

3) Using the ST1 and ST2, remove the snap ring.
ST1 398673600 COMPRESSOR
ST2 498627100 SEAT

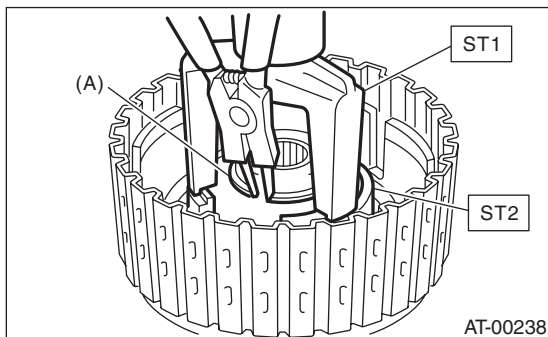

(A) Snap ring

4) Take out the clutch cover, spring retainer, high clutch piston and reverse clutch piston.

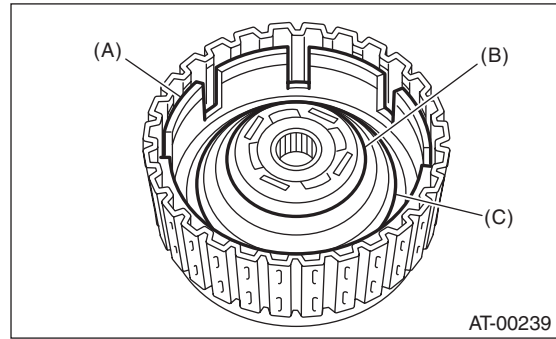

(A) Reverse clutch piston
(B) Cover
(C) Return spring

5) Remove the seal ring and lip seal from the high clutch piston and reverse clutch piston.

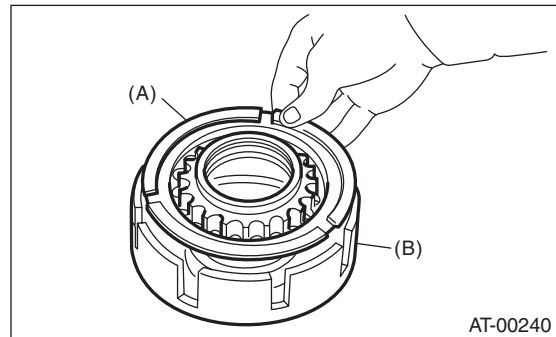

(A) High clutch piston
(B) Reverse clutch piston

2. PLANETARY GEAR AND LOW CLUTCH

1) Remove the snap ring from low clutch drum.

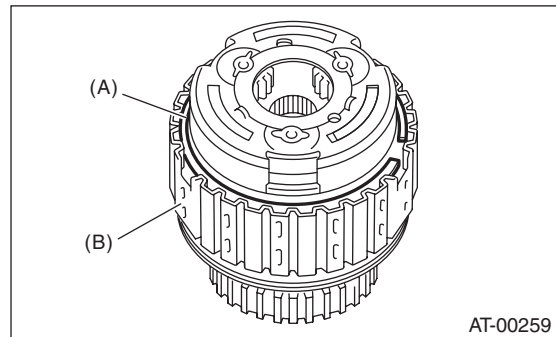

(A) Snap ring
(B) Low clutch drum

2) Take out the front planetary carrier.

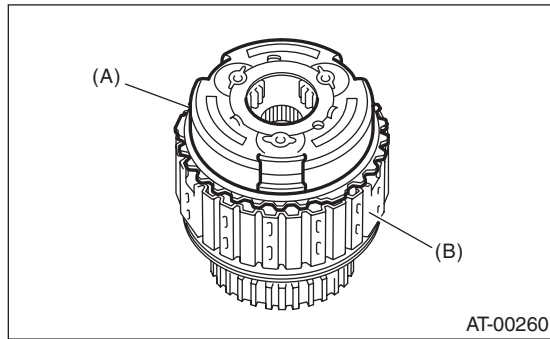

- (A) Front planetary carrier
- (B) Low clutch drum

5) Take out the rear internal gear.

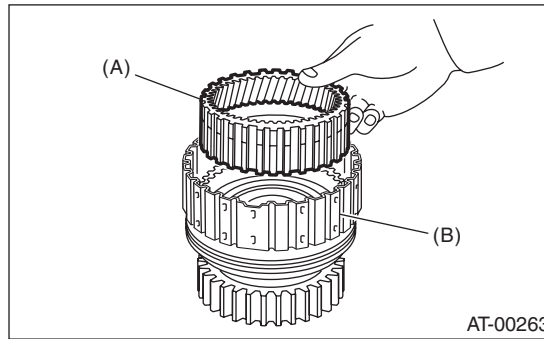

- (A) Rear internal gear
- (B) Low clutch drum

3) Take out the rear sun gear.

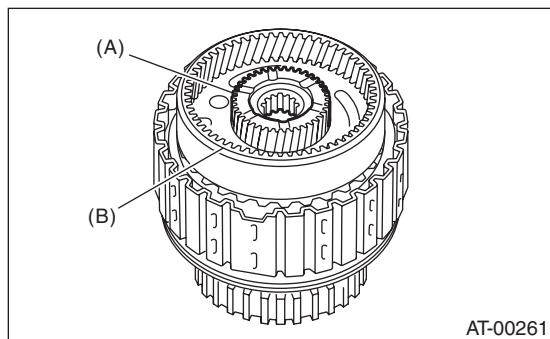

- (A) Rear sun gear
- (B) Rear planetary carrier

6) Remove the snap ring from low clutch drum.

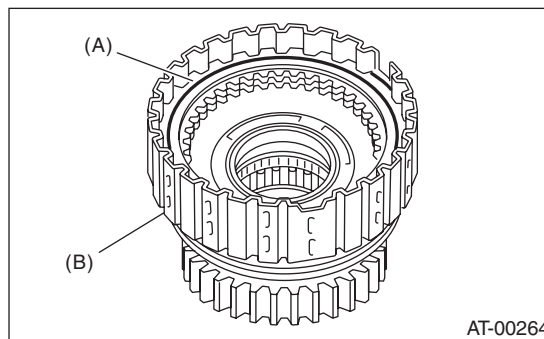

- (A) Snap ring
- (B) Low clutch drum

4) Take out the rear planetary carrier, washer and thrust needle bearing.

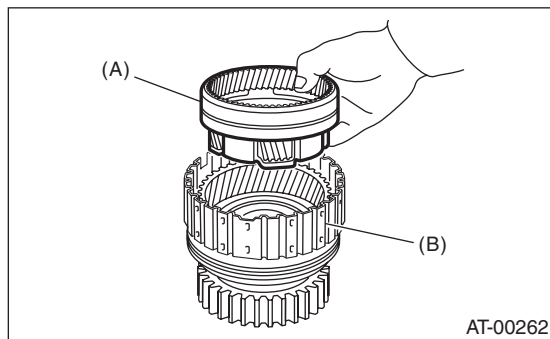

- (A) Rear planetary carrier
- (B) Low clutch drum

7) Compress the spring retainer and remove the snap ring from the low clutch drum using ST1 and ST2.

ST1 498627100 SEAT
ST2 398673600 COMPRESSOR

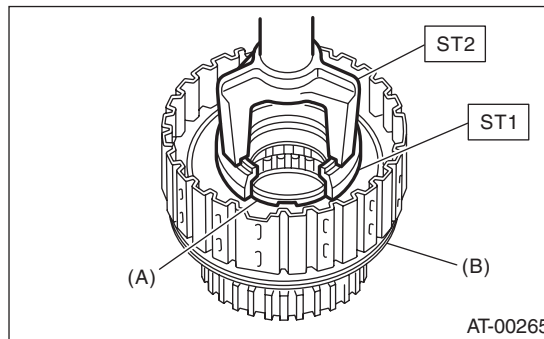

- (A) Snap ring
- (B) Low clutch drum

8) Remove the one-way clutch. <Ref. to 4AT-101, REMOVAL, AT Main Case.>

AT Main Case

AUTOMATIC TRANSMISSION

9) Install the one-way clutch inner race to the low clutch drum, and then apply compressed air to remove the low clutch piston.

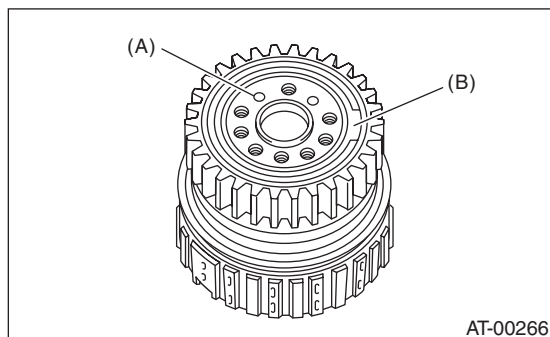

- (A) Apply compressed air.
- (B) One-way clutch inner race

10) Remove the one-way clutch inner race.

11) Remove the one-way clutch after taking out the snap ring.

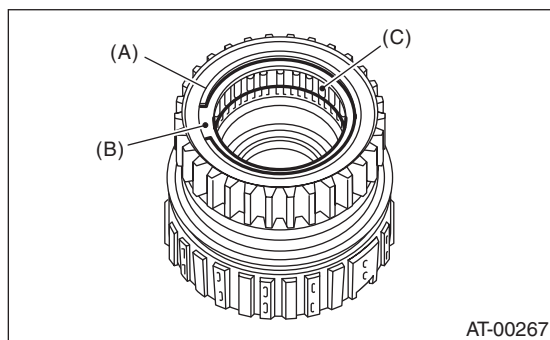

- (A) Snap ring
- (B) Plate
- (C) One-way clutch

12) Remove the needle bearing after taking out the snap ring.

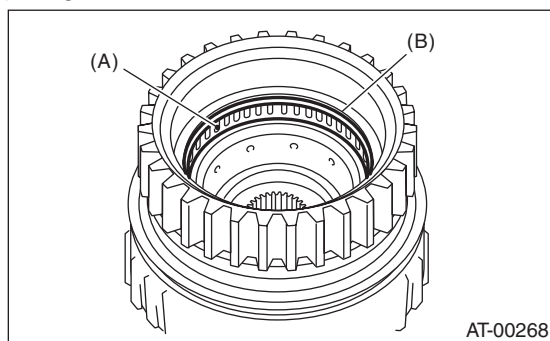

- (A) Needle bearing
- (B) Snap ring

3. 2-4 BRAKE

Separate the 2-4 brake piston and piston retainer.

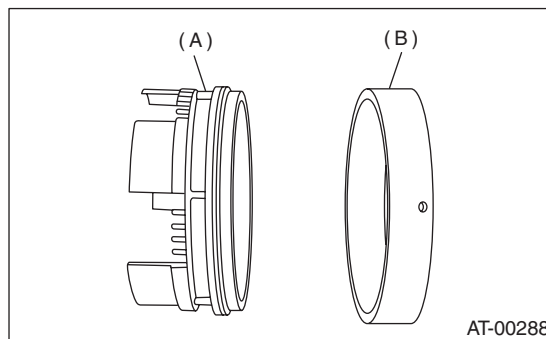

- (A) 2-4 brake piston
- (B) 2-4 brake piston retainer

4. ONE-WAY CLUTCH INNER RACE

1) Remove the seal ring.

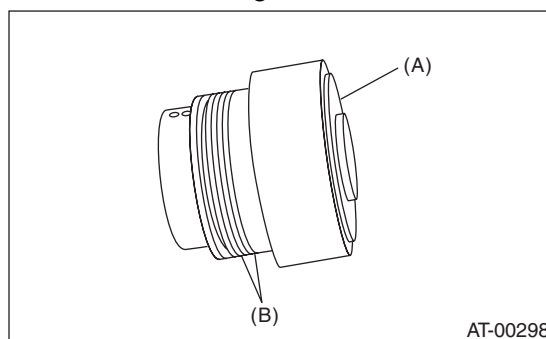

- (A) One-way clutch inner race
- (B) Seal ring

2) Remove the needle bearing using ST.
ST 398527700 PULLER ASSY

5. ONE-WAY CLUTCH OUTER RACE

1) Remove the one-way clutch after taking out the snap ring.

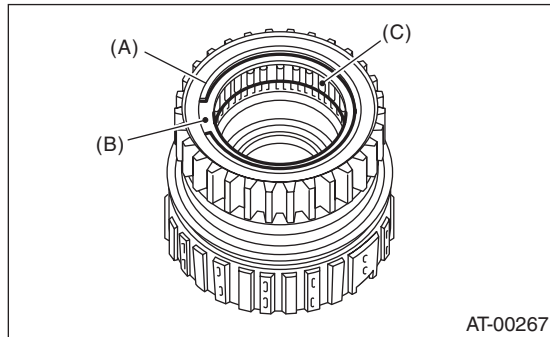

- (A) Snap ring
- (B) Plate
- (C) One-way clutch

2) Remove the needle bearing after taking out the snap ring.

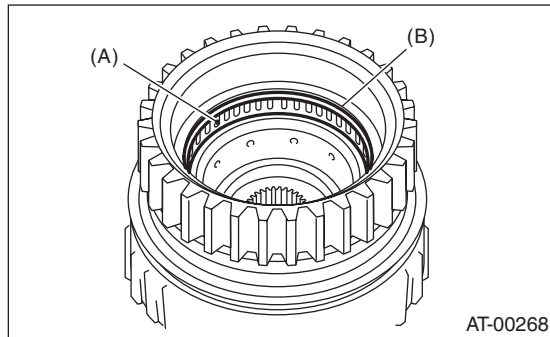

- (A) Needle bearing
- (B) Snap ring

D: ASSEMBLY

1. HIGH CLUTCH AND REVERSE CLUTCH

1) Install the seal ring and lip seal to the high clutch piston and reverse clutch piston.

2) Install the high clutch piston to the reverse clutch piston.

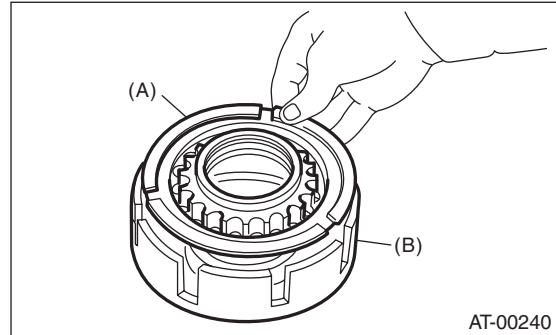

- (A) High clutch piston
- (B) Reverse clutch piston

3) Install the reverse clutch piston to the high clutch drum. Align the groove on reverse clutch piston with the groove on high clutch drum during installation.

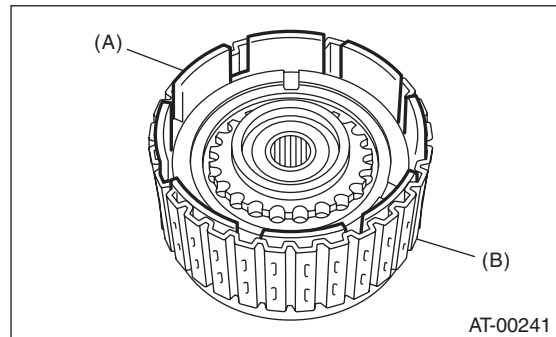

- (A) Reverse clutch piston
- (B) High clutch drum

4) Install the spring retainer to the high clutch piston.

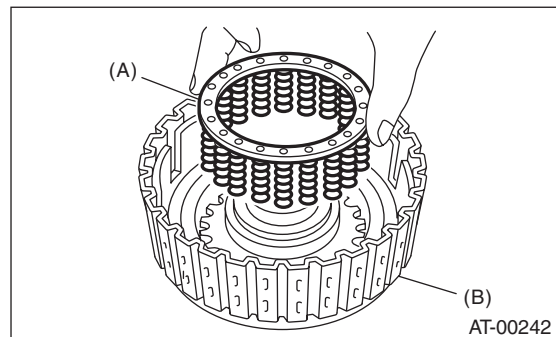

- (A) Spring retainer
- (B) High clutch drum

AT Main Case

AUTOMATIC TRANSMISSION

- 5) Attach the ST to the high clutch piston.
 ST 498437000 HIGH CLUTCH PISTON GUIDE

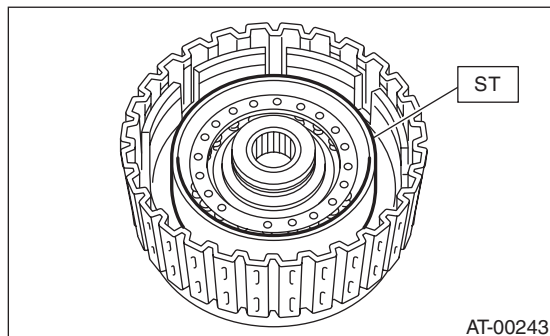

- 6) Install the cover to the high clutch piston while making sure not to bend the high clutch piston seal.

- 7) Install the snap ring using ST1 and ST2.

- ST1 398673600 COMPRESSOR
 ST2 498627100 SEAT
 ST3 498437000 HIGH CLUTCH PISTON GUIDE

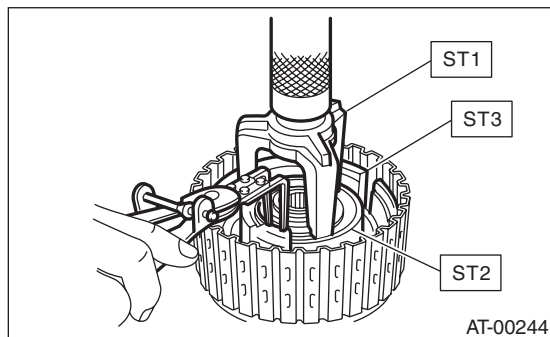

- 8) Place the dish plate, driven plate, drive plate and retaining plate neatly in this order on surface table.

- 9) Set the micro gauge to retaining plate, and read its scale.

NOTE:

The value, which is read in the gauge at this time, is zero point.

- 10) Scale and record the weight "Z" of a flat board which will be put on retaining plate.

NOTE:

- Use a stiff board which does not bend against load as a flat board to be put on retaining plate.
- Use a flat board weighing less than 250 N (25.5 kgf, 56.2 lb).

- 11) Put the flat board on retaining plate.

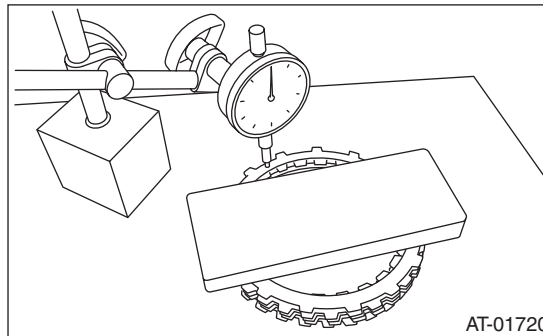

- 12) Using the following formula, read the push/pull gauge, and calculate "N".

$$N = 250 \text{ N (25.5 kgf, 56.2 lb)} - Z$$

N: Value indicated on push/pull gauge

250 N (25.5 kgf, 56.2 lb) : Load applied to clutch plate

Z: Flat board weight

- 13) Press the center of retaining plate by applying a force of N using push/pull gauge, and then measure and record the height A. Measure at three locations or more spaced by equal distances and take the average value.

NOTE:

If measuring in three locations, measure every 120°. If measuring in four locations, measure every 90°.

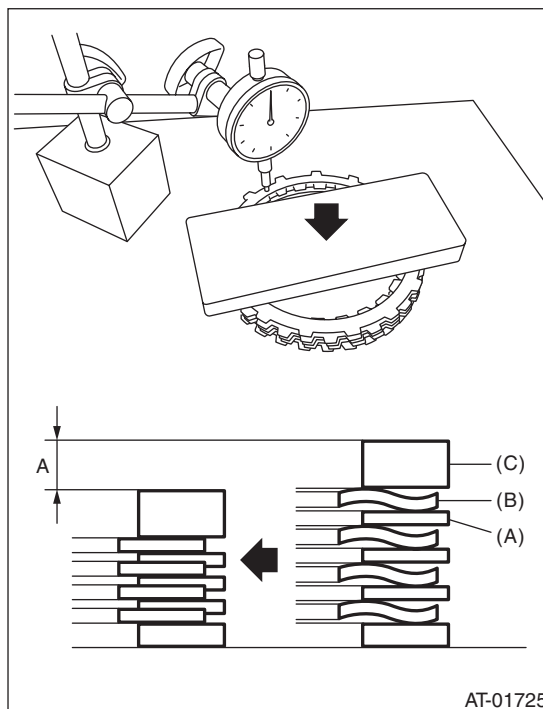

- (A) Driven plate
 (B) Drive plate
 (C) Retaining plate

14) Install the thickest driven plate to piston side, and then install the driven plate, drive plate, retaining plate to high clutch drum.

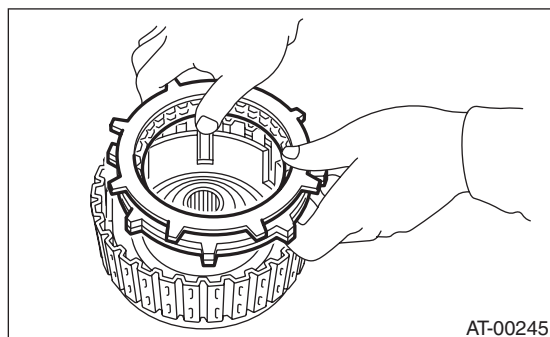

15) Install the snap ring to high clutch drum.
16) Apply compressed air intermittently to check for operation.

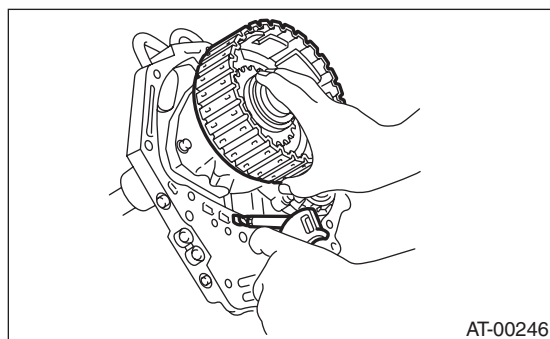

17) Measure and record the clearance B between the retaining plate and snap ring. (High clutch)
At this time, do not press down the retaining plate.

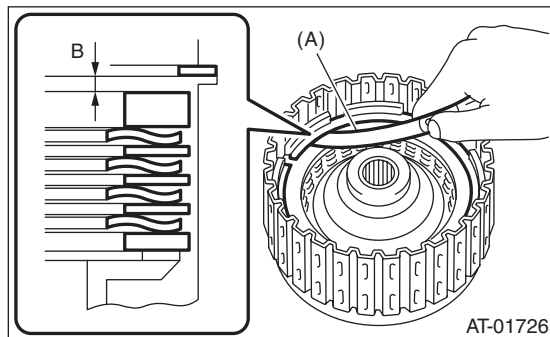

(A) Thickness gauge

18) Piston stroke calculation
Calculate with A and B dimensions recorded before. If the calculated value exceeds the service limit, replace the drive plate with a new part and adjust it within the initial specification.

$$T = A + B$$

T: Piston stroke

A: Amount of drive plate compression

B: Clearance between retaining plate and snap ring

Initial standard:

2.0 — 2.3 mm (0.079 — 0.091 in)

Limit thickness:

2.6 mm (0.102 in)

High clutch retaining plate	
Part number	Thickness mm (in)
31567AA710	4.7 (0.185)
31567AA720	4.8 (0.189)
31567AA730	4.9 (0.193)
31567AA740	5.0 (0.197)
31567AA670	5.1 (0.201)
31567AA680	5.2 (0.205)
31567AA690	5.3 (0.209)
31567AA700	5.4 (0.213)

19) Place the dish plate, driven plate, drive plate and retaining plate neatly in this order on surface table.

20) Set the micro gauge to retaining plate, and read its scale.

NOTE:

The value, which is read in the gauge at this time, is zero point.

21) Scale and record the weight "Z" of a flat board which will be put on retaining plate.

NOTE:

- Use a stiff board which does not bend against load as a flat board to be put on retaining plate.

- Use a flat board of its weight less than 150 N (15.3 kgf, 33.7 lb).

22) Put the flat board on retaining plate.

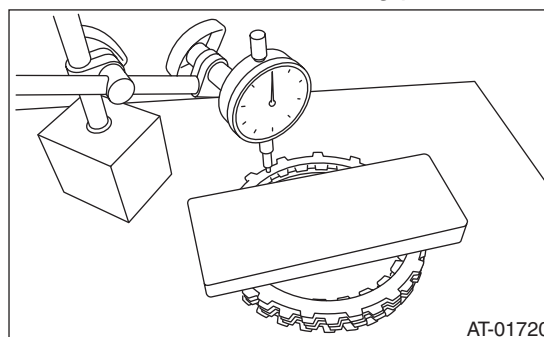

AT Main Case

AUTOMATIC TRANSMISSION

23) Using the following formula, read the push/pull gauge, and calculate "N".

$$N = 150 N (15.3 \text{ kgf}, 33.7 \text{ lb}) - Z$$

N: Value indicated on push/pull gauge

150 N (15.3 kgf, 33.7 lb) : Load applied to clutch plate

Z: Flat board weight

24) Press the center of retaining plate by applying a force of N using push/pull gauge, and then measure and record the height A. Measure at three locations or more spaced by equal distances and take the average value.

NOTE:

If measuring in three locations, measure every 120°. If measuring in four locations, measure every 90°.

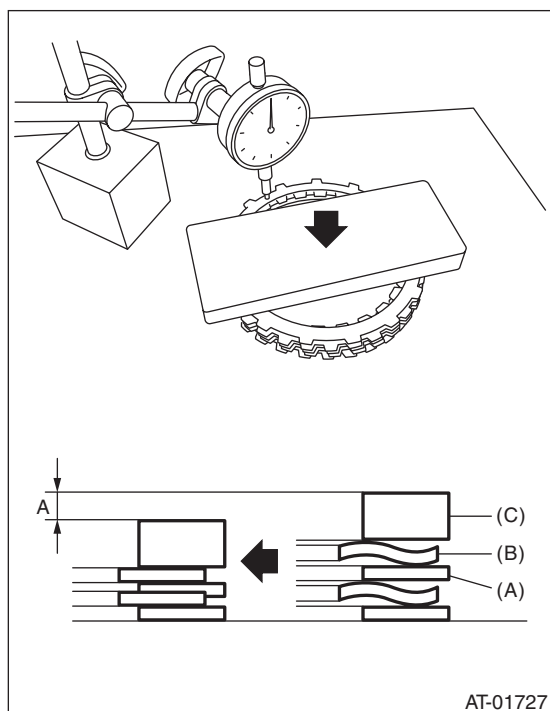

- (A) Driven plate
- (B) Drive plate
- (C) Retaining plate

25) Install the driven plate, drive plate, retaining plate and snap ring.

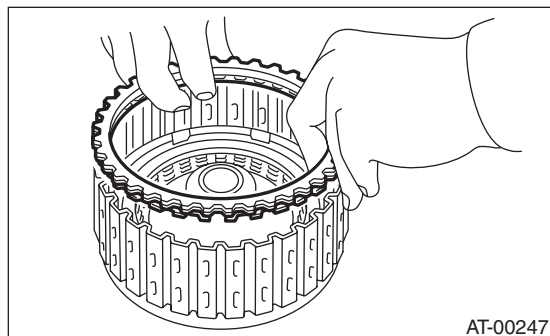

26) Apply compressed air intermittently to check for operation.

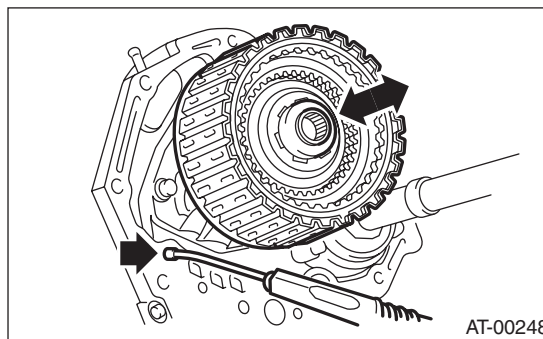

27) Measure and record the clearance B between the retaining plate and snap ring. (Reverse clutch) At this time, do not press down the retaining plate.

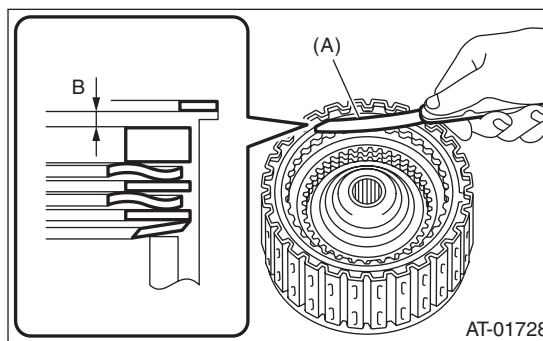

(A) Thickness gauge

28) Piston stroke calculation

Calculate with A and B dimensions recorded before. If the calculated value exceeds the service limit, replace the drive plate with a new part and adjust it within the initial specification.

$$T = A + B$$

T: Piston stroke

A: Amount of drive plate compression

B: Clearance between retaining plate and snap ring

Initial standard:

1.1 — 1.4 mm (0.043 — 0.055 in)

Limit thickness:

1.6 mm (0.063 in)

Reverse clutch retaining plate	
Part number	Thickness mm (in)
31567AA910	4.0 (0.157)
31567AA920	4.2 (0.165)
31567AA930	4.4 (0.173)
31567AA940	4.6 (0.181)
31567AA950	4.8 (0.189)
31567AA960	5.0 (0.197)
31567AA970	5.2 (0.205)
31567AA980	5.4 (0.213)

2. PLANETARY GEAR AND LOW CLUTCH

- 1) Apply ATF to the D-ring, and then install it to the low clutch piston.
- 2) Install the low clutch piston to low clutch drum.

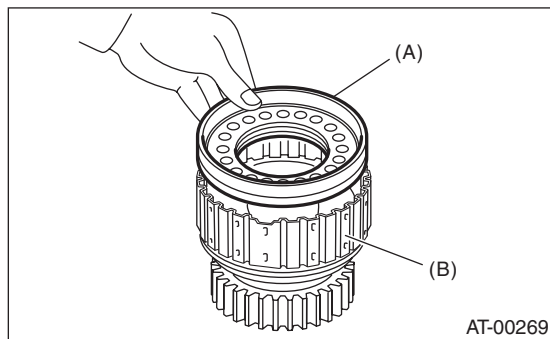

- (A) Low clutch piston
- (B) Low clutch drum

- 3) Install the spring retainer to low clutch piston.

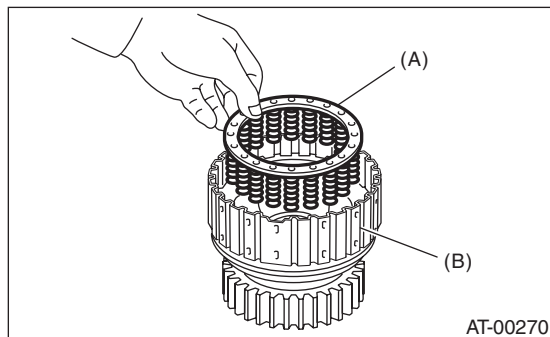

- (A) Spring retainer
- (B) Low clutch drum

- 4) Attach the ST to the low clutch drum.
- ST 498437100 LOW CLUTCH PISTON GUIDE

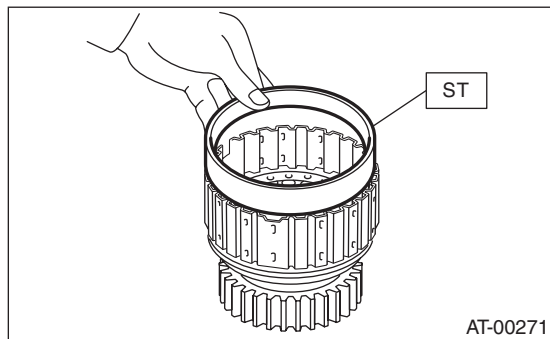

- 5) Using ST1 and ST2, set the cover on the piston and press against it, and attach the snap ring. At this time, be careful not to bend the cover seal.

- ST1 498627100 SEAT
 ST2 398673600 COMPRESSOR
 ST3 498437100 LOW CLUTCH PISTON GUIDE

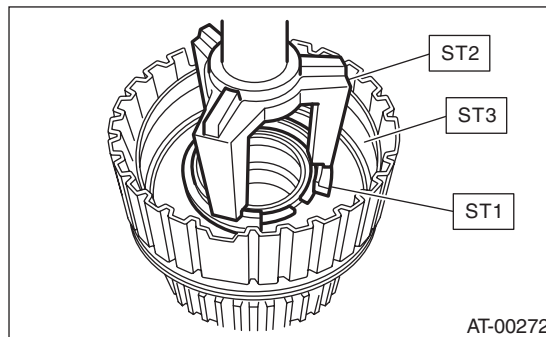

- 6) Install the dish plate, driven plate, drive plate and retaining plate, and then secure them with a snap ring.

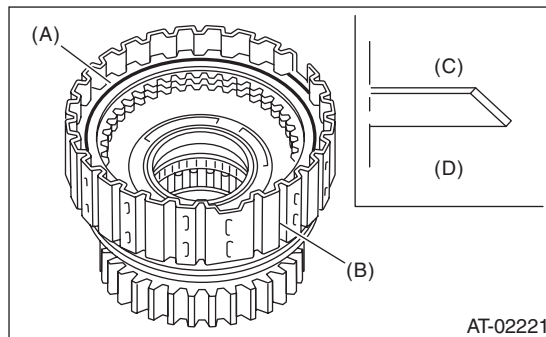

- (A) Snap ring
- (B) Low clutch drum
- (C) Dish plate
- (D) Low clutch piston side

- 7) Check the low clutch for operation.
 - (1) Remove the one-way clutch. <Ref. to 4AT-101, REMOVAL, AT Main Case.>
 - (2) Set the one-way clutch inner race, and apply compressed air for checking.

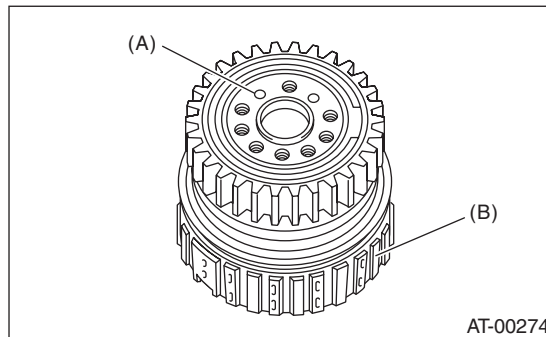

- (A) Apply compressed air.
- (B) Low clutch drum

AT Main Case

AUTOMATIC TRANSMISSION

8) Check the low clutch clearance.

- (1) Place same thickness shims on both sides to prevent plate from tilting.
- (2) Check the clearance between retaining plate and low clutch operation.

Initial standard:

0.7 — 1.1 mm (0.028 — 0.043 in)

Limit thickness:

1.6 mm (0.063 in)

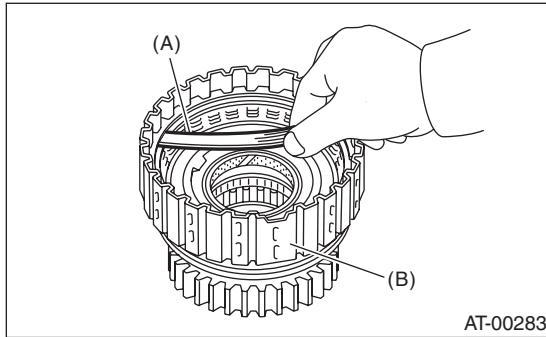

- (A) Thickness gauge
- (B) Low clutch drum

If the clearance exceeds the service limits, replace the drive plate and select and adjust the retaining plate to within default standard values.

Retaining plate	
Part number	Thickness mm (in)
31567AB050	3.8 (0.150)
31567AB060	4.0 (0.157)
31567AB070	4.2 (0.165)
31567AB080	4.4 (0.173)
31567AB090	4.6 (0.181)

9) Install the washer to the rear internal gear.

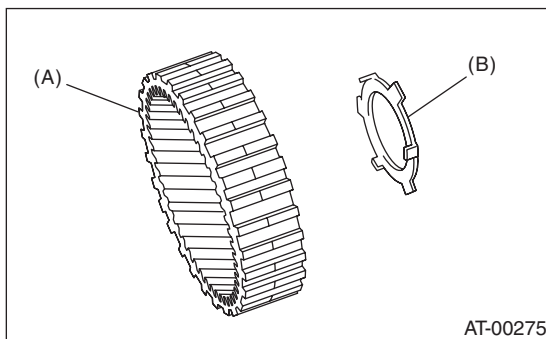

- (A) Rear internal gear
- (B) Washer

10) Install the rear internal gear.

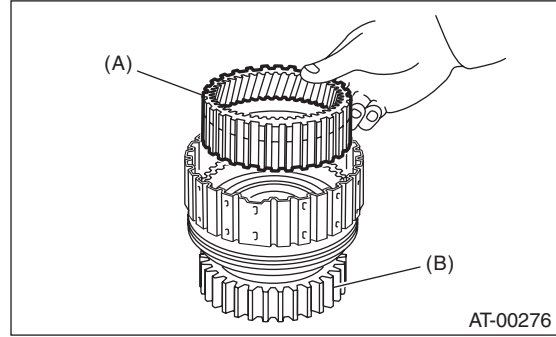

- (A) Rear internal gear
- (B) Low clutch drum

11) Install the thrust needle bearing in the correct direction.

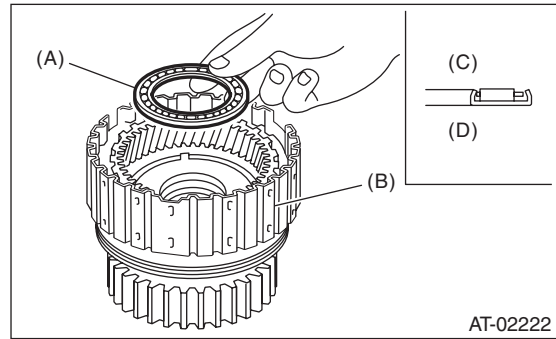

- (A) Thrust needle bearing
- (B) Low clutch drum
- (C) Rear planetary, carrier side
- (D) Low clutch piston side

12) Install the washer by aligning the protrusion of the washer with the hole of the rear planetary carrier.

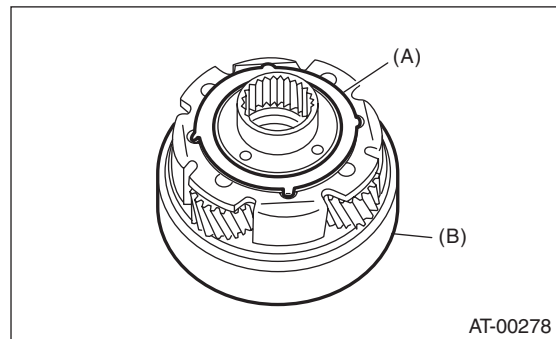

- (A) Washer
- (B) Rear planetary carrier

13) Install the rear planetary carrier to the low clutch drum.

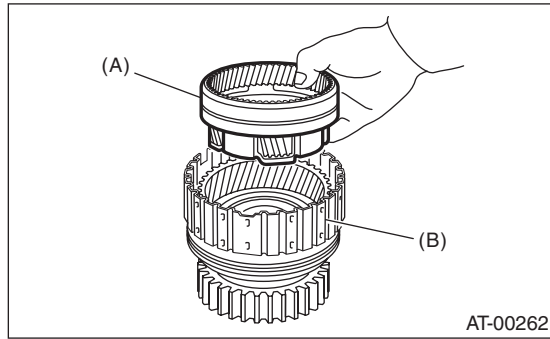

- (A) Rear planetary carrier
- (B) Low clutch drum

16) Install the thrust needle bearing in the proper direction.

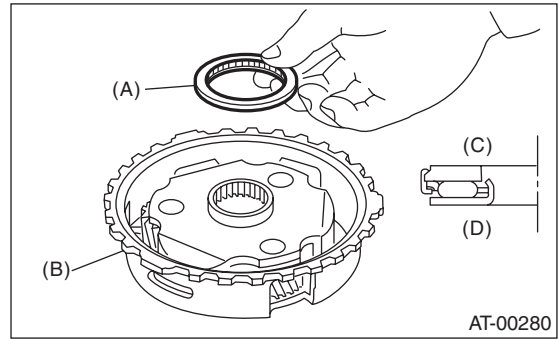

- (A) Thrust needle bearing
- (B) Front planetary carrier
- (C) Rear sun, gear side
- (D) Front planetary, carrier side

14) Install the thrust needle bearing in the correct direction.

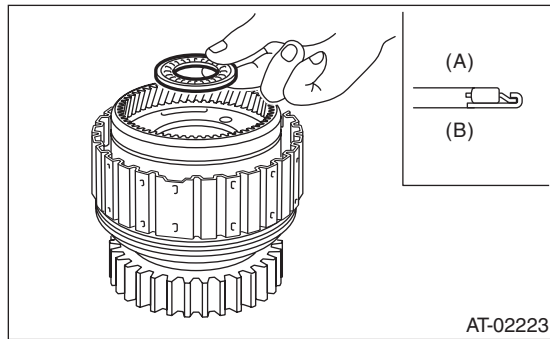

- (A) Rear sun, gear side
- (B) Rear planetary, carrier side

17) Install the front planetary carrier to the low clutch drum.

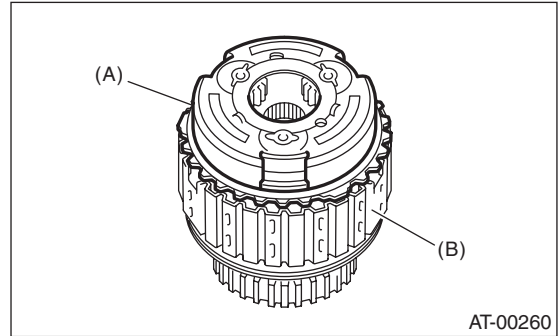

- (A) Front planetary carrier
- (B) Low clutch drum

15) Install the rear sun gear in the proper direction.

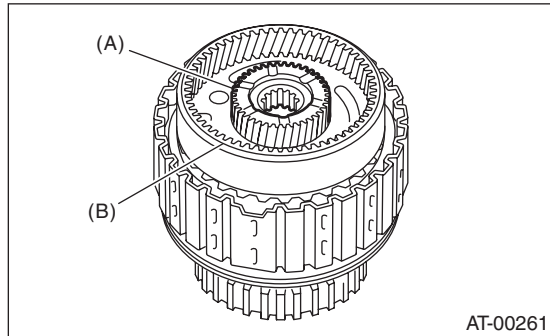

- (A) Rear sun gear
- (B) Rear planetary carrier

18) Install the snap ring to the low clutch drum.

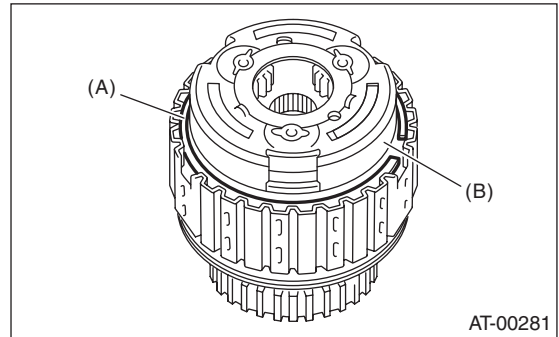

- (A) Snap ring
- (B) Front planetary carrier

AT Main Case

AUTOMATIC TRANSMISSION

19) Install the needle bearing, and then secure with the snap ring.

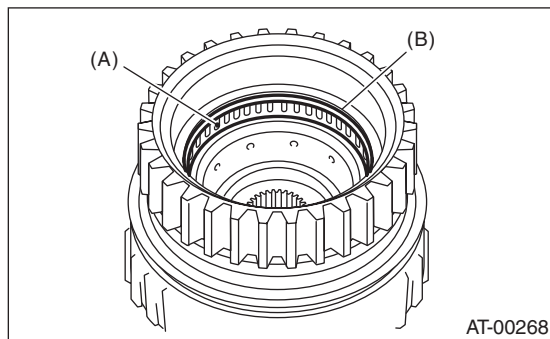

- (A) Needle bearing
- (B) Snap ring

20) Install the one-way clutch and one-way clutch inner race, then secure with the snap ring.

21) Set the inner race. Make sure that the clutch locks in the clockwise direction and rotates freely in the counterclockwise direction.

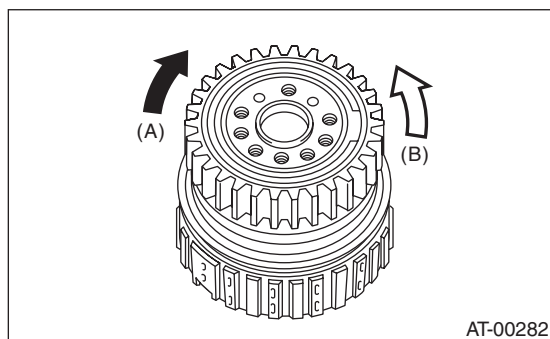

- (A) Locked
- (B) Free

3. 2-4 BRAKE

1) Apply ATF to the D-ring, and then install it to the 2-4 brake piston.

2) Install 2-4 brake piston to 2-4 brake piston retainer.

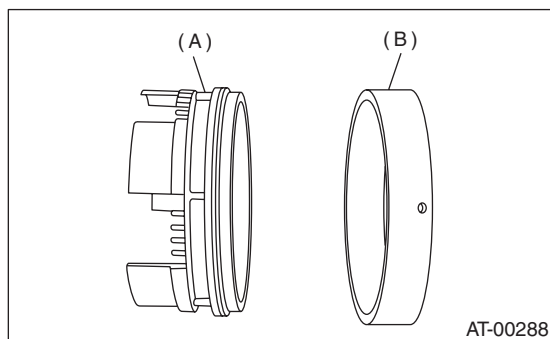

- (A) 2-4 brake piston
- (B) 2-4 brake piston retainer

4. ONE-WAY CLUTCH INNER RACE

1) Install the needle bearing to inner race using ST and a press.

ST 398497701 SEAT

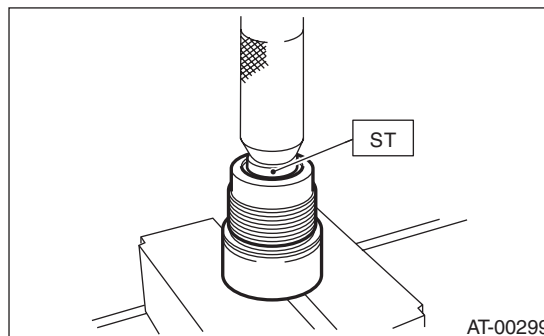

2) Apply vaseline to the groove of the inner race and seal ring.

3) Install two seal rings to the one-way clutch inner race.

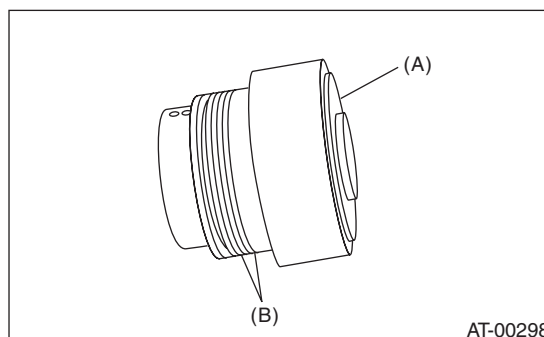

- (A) One-way clutch inner race
- (B) Seal ring

5. ONE-WAY CLUTCH OUTER RACE

1) Install the needle bearing, and then secure with the snap ring.

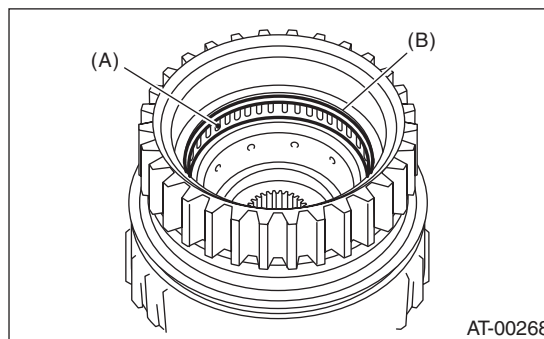

- (A) Needle bearing
- (B) Snap ring

2) Install the one-way clutch, and then secure with the snap ring.

3) Set the inner race. Make sure that the clutch locks in the clockwise direction and rotates freely in the counterclockwise direction.

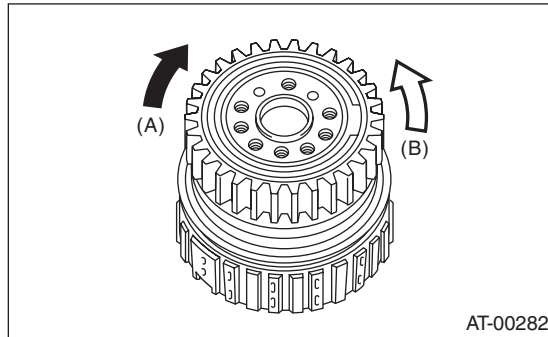

- (A) Locked
- (B) Free

E: INSPECTION

1. HIGH CLUTCH AND REVERSE CLUTCH

Check the following items.

- Drive plate facing for wear or damage
- Driven plate for discoloration (burned color)
- Snap ring wear, return spring setting and breakage, and snap ring retainer deformation
- Lip seal and D-ring damage
- Piston and drum check ball operation
- Adjust the total end play. <Ref. to 4AT-87, ADJUSTMENT, Oil Pump Housing.>

2. PLANETARY GEAR AND LOW CLUTCH

Check the following items.

- Drive plate facing for wear or damage
- Driven plate for discoloration (burned color)
- Snap ring wear, return spring setting and breakage, and spring retainer deformation
- Lip seal and D-ring damage
- Piston check ball operation
- Measure the total end play and adjust it to be within specifications. <Ref. to 4AT-87, ADJUSTMENT, Oil Pump Housing.>

3. 2-4 BRAKE

Check the following items.

- Drive plate facing for wear or damage
- Driven plate for discoloration (burned color)
- Snap ring wear and spring retainer deformation
- Lip seal and D-ring damage
- Measure the total end play and adjust it to be within specifications. <Ref. to 4AT-87, ADJUSTMENT, Oil Pump Housing.>

4. ONE-WAY CLUTCH

- Check that the snap ring is not damaged and the seal ring is not deformed.
- Measure the total end play and adjust it to be within specifications. <Ref. to 4AT-87, ADJUSTMENT, Oil Pump Housing.>

5. LOW & REVERSE BRAKE

Check the following items.

- Drive plate facing for wear or damage
- Driven plate for discoloration (burned color)
- Snap ring wear and spring retainer deformation