

9. Automatic Transmission Assembly

A: REMOVAL

- 1) Set the vehicle on a lift.
- 2) Open the front hood and support with the hood stay.
- 3) Disconnect the ground cable from the battery.
- 4) Remove the air intake duct.
<Ref. to IN(H4SO)-8, REMOVAL, Air Intake Duct.>
- 5) Remove the air intake chamber.
<Ref. to IN(H4SO)-7, REMOVAL, Air Intake Chamber.>
- 6) Remove the air cleaner case stay.

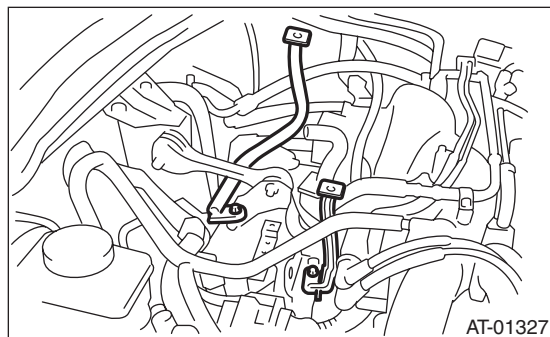

- 7) Disconnect the following connectors.
 - (1) Transmission harness connectors

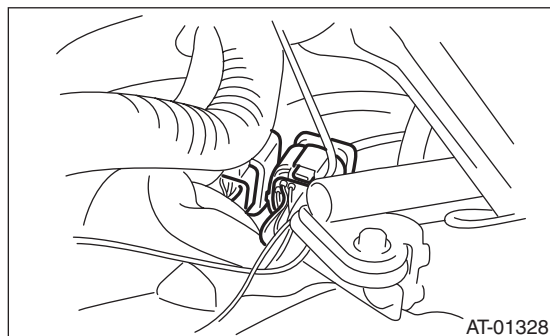

- (2) Transmission ground terminal

- 8) Remove the starter.
<Ref. to SC(H4SO)-6, REMOVAL, Starter.>
- 9) Remove the pitching stopper.

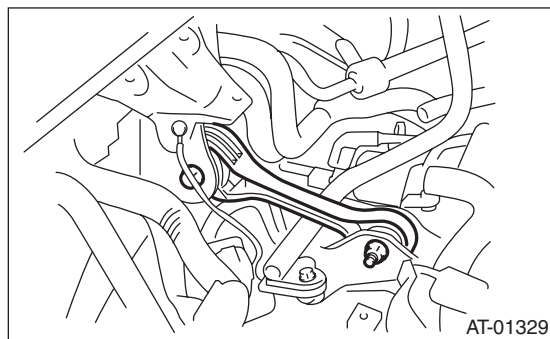

- 10) Separate the torque converter assembly from the drive plate.
 - (1) Remove the V-belt covers.

- (2) Remove the service hole plug.
- (3) Remove the bolts which hold the torque converter assembly to the drive plate.
- (4) Place the wrench on the crank pulley bolt, and remove all the bolts while rotating the crank pulley a little bit at a time.

CAUTION:

Be careful not to drop bolts into the converter case.

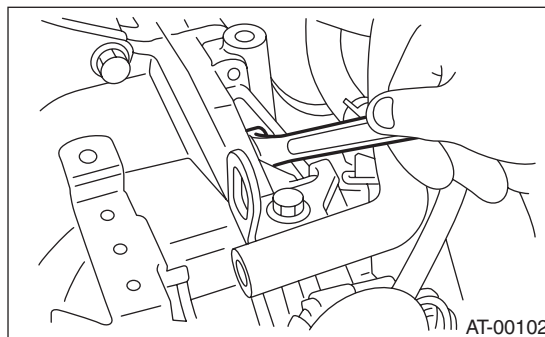

- 11) Attach the ST to the converter case.
ST 498277200 STOPPER SET

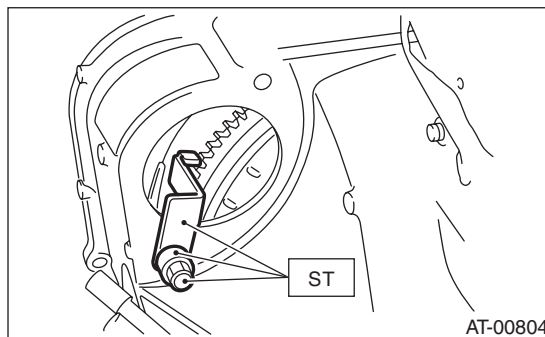

- 12) Remove the ATF level gauge.

NOTE:

Plug the opening to prevent entry of foreign particles into the transmission fluid.

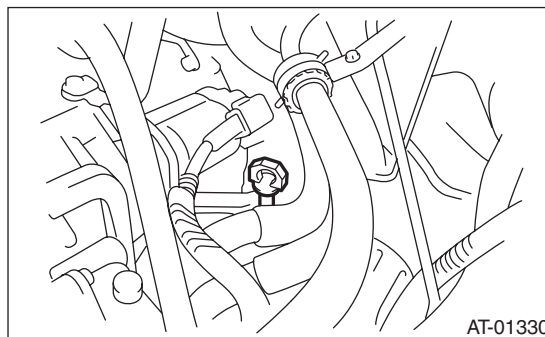

- 13) Remove the throttle body. <Ref. to FU(H4SO)-10, REMOVAL, Throttle Body.>
- 14) Disconnect the engine harness, then remove the harness connector from the engine harness bracket.

Automatic Transmission Assembly

AUTOMATIC TRANSMISSION

15) Remove the engine harness bracket.

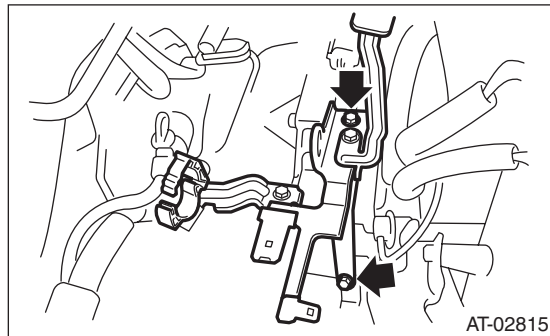

16) Remove the pitching stopper bracket.

17) Set the ST.

ST 41099AC000 ENGINE SUPPORT ASSY

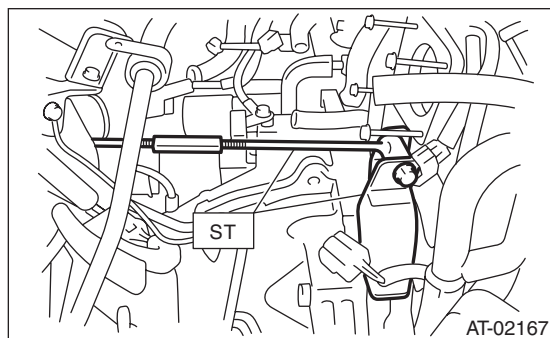

18) Remove the bolts which hold the upper side of the transmission to the engine.

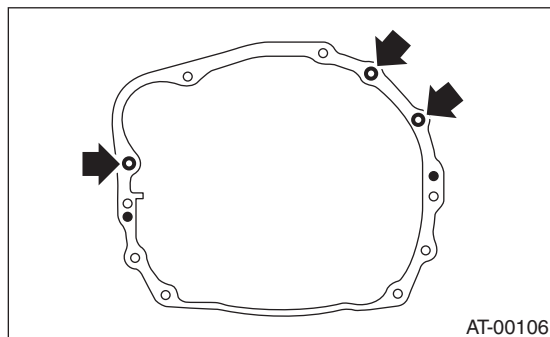

19) Lift-up the vehicle.

20) Remove the under cover.

21) Remove the front, center and rear exhaust pipes and the muffler.

<Ref. to EX(H4SO)-4, REMOVAL, Front Exhaust Pipe.> <Ref. to EX(H4SO)-8, REMOVAL, Rear Exhaust Pipe.> <Ref. to EX(H4SO)-10, REMOVAL, Muffler.>

22) Remove the heat shield cover.

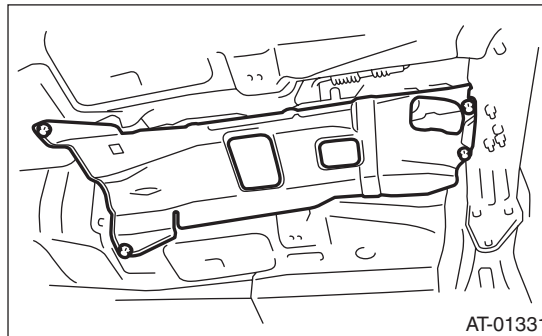

23) Remove the ATF drain plug to drain ATF.

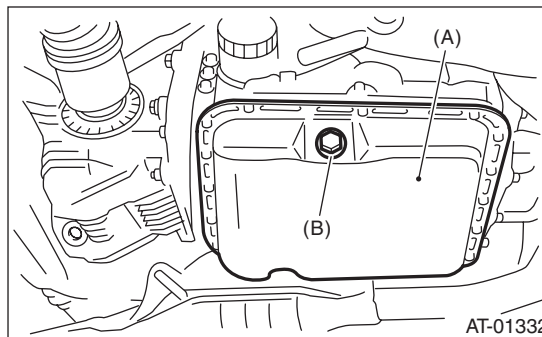

(A) Oil pan

(B) ATF drain plug

24) Disconnect the ATF cooler hoses from the pipes of the transmission side, and remove the oil charge pipe.

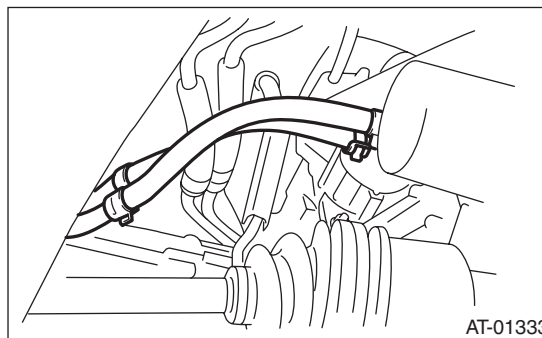

25) Remove the propeller shaft.

<Ref. to DS-10, REMOVAL, Propeller Shaft.>

26) Remove the shift select cable.

<Ref. to CS-23, REMOVAL, Select Cable.>

27) Remove the brackets (two) which hold front stabilizer.

Automatic Transmission Assembly

AUTOMATIC TRANSMISSION

28) Remove the bolt securing the ball joint of the front arm to housing.

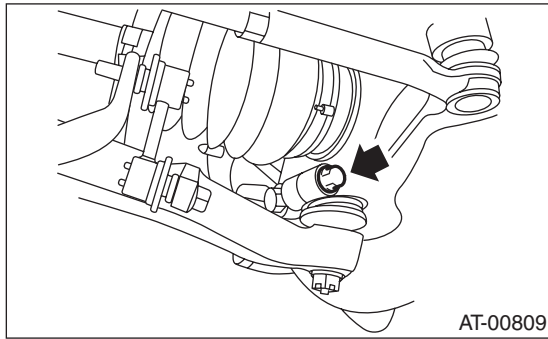

29) Pull out the front drive shaft from the transmission.

(1) Using a tire lever or a crow bar, etc., pull out until the front drive shaft transmission side joint slides move smoothly.

NOTE:

Place cloth between the tire lever or bar and the transmission in order to avoid damaging the transmission side retainer.

(2) Hold the transmission side joint of the front drive shaft by hand and extract the housing from the transmission while pressing the housing outward, so as not to stretch the boot.

30) Remove the bolts which hold the clutch housing cover.

31) Remove the bolts which hold the lower side of transmission to the engine.

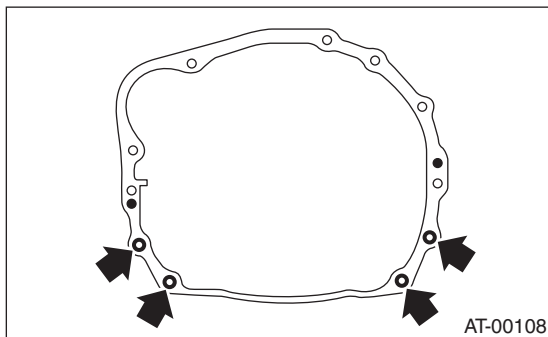

32) Place the transmission jack under the transmission.

NOTE:

Make sure that the support plates of transmission jack do not touch the oil pan.

33) Remove the transmission rear crossmember from the vehicle.

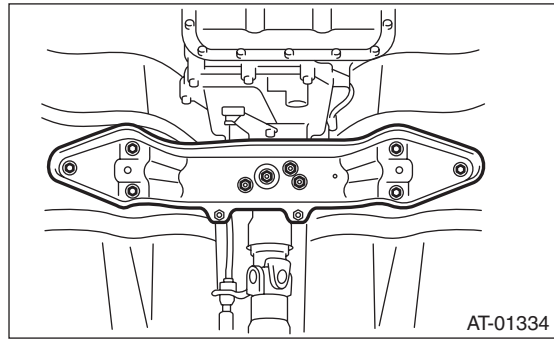

34) While lowering the transmission jack gradually, fully retract the engine support, and then tilt the engine rearward.

NOTE:

Retract the support until the clearance between front crossmember and converter case becomes approx. 10 mm (0.39 in).

35) Remove the transmission.

CAUTION:

Remove the transmission and torque converter as a single unit from engine.

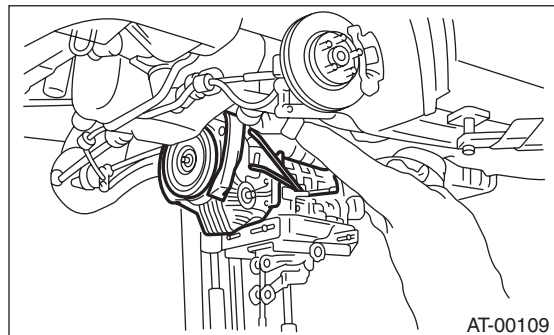

36) Remove the rear cushion rubber from the transmission assembly.

Automatic Transmission Assembly

AUTOMATIC TRANSMISSION

B: INSTALLATION

1) Replace the differential side oil seal with a new part.

NOTE:

When a new oil seal has been installed, replacement is not required.

2) Install the rear cushion rubber to the transmission assembly.

Tightening torque:

40 N·m (4.1 kgf-m, 30 ft-lb)

3) Attach the ST to the converter case.

ST 498277200 STOPPER SET

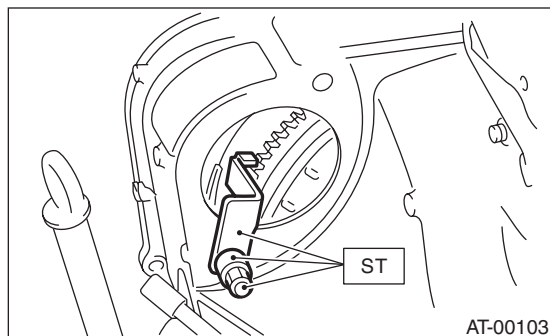

4) Install the transmission onto the engine.

(1) Lift-up the transmission gradually using transmission jack.

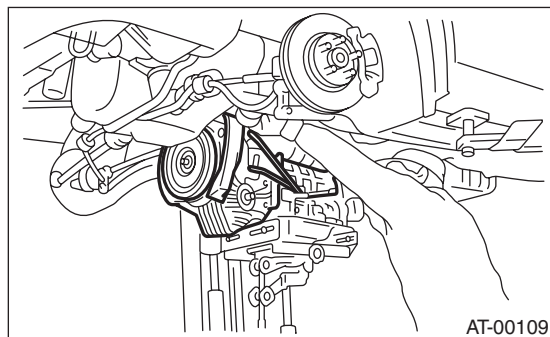

(2) Engage at the spline section.

(3) While raising the transmission gradually, turn the screw of engine support, and then tilt the engine forward.

5) Install the transmission rear crossmember.

Tightening torque:

T1: 35 N·m (3.6 kgf-m, 26 ft-lb)

T2: 75 N·m (7.6 kgf-m, 55 ft-lb)

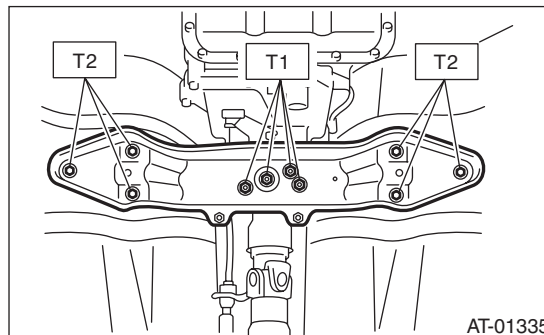

6) Remove the transmission jack.

7) Tighten the bolts which hold the lower side of the transmission to the engine.

Tightening torque:

50 N·m (5.1 kgf-m, 36.9 ft-lb)

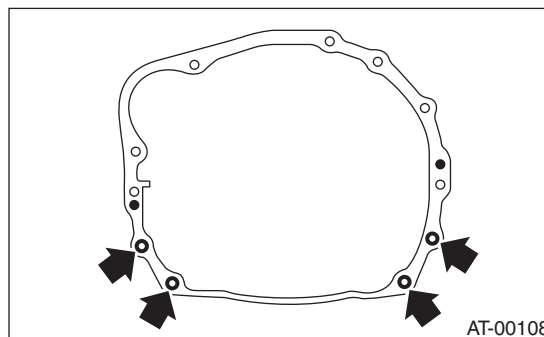

8) Install the clutch housing cover bolts.

9) Lower the lift.

10) Connect the engine and transmission.

(1) Remove the ST from converter case.

NOTE:

When removing the ST, be careful not to drop it into converter case.

ST 498277200 STOPPER SET

(2) Install the starter.

<Ref. to SC(H4SO)-6, INSTALLATION, Starter.>

(3) Tighten the bolts which hold the upper side of the transmission to engine.

Tightening torque:

50 N·m (5.1 kgf-m, 36.9 ft-lb)

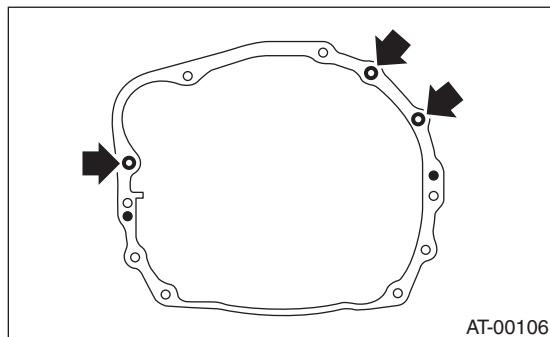

AT-00106

11) Install the torque converter assembly to the drive plate.

- (1) Tighten the bolts which hold the torque converter assembly to the drive plate.
- (2) Place the wrench on the crank pulley bolt, and remove all the bolts while rotating the crank pulley a little bit at a time.

Tightening torque:

25 N·m (2.5 kgf-m, 18 ft-lb)

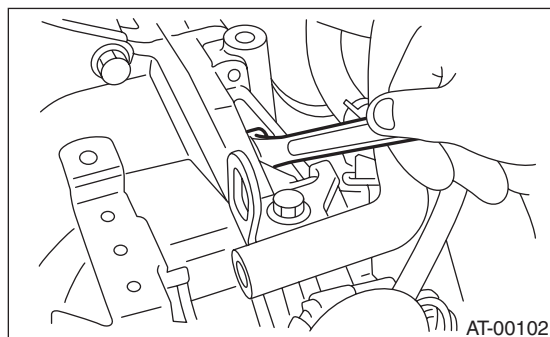

AT-00102

- (3) Fit the plug to service hole.
- (4) Install the V-belt cover.

12) Remove the ST.

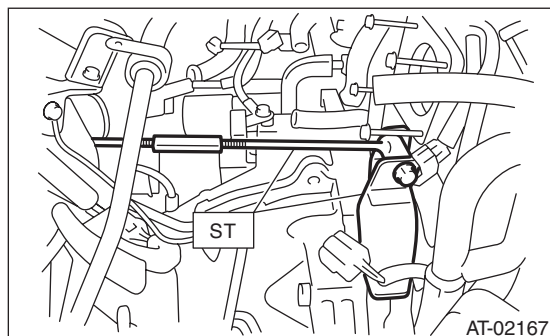

AT-02167

13) Install the engine harness bracket.

Tightening torque:

T1: 16 N·m (1.6 kgf-m, 11.6 ft-lb)

T2: 36 N·m (3.6 kgf-m, 26.0 ft-lb)

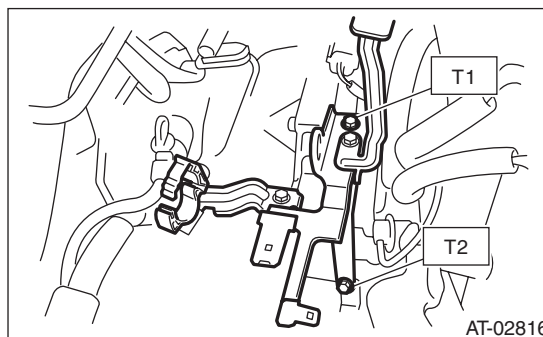

AT-02816

14) Install the harness connector to engine harness bracket, then connect the harness.

15) Install the pitching stopper bracket.

Tightening torque:

41 N·m (4.2 kgf-m, 30.4 ft-lb)

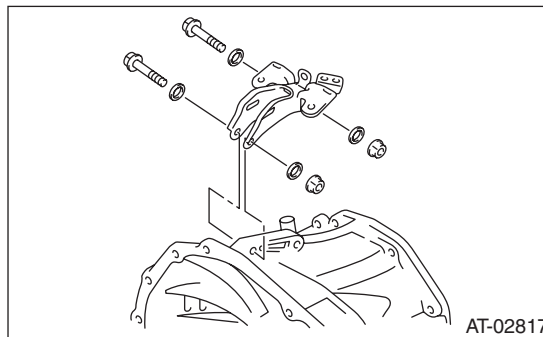

AT-02817

16) Install the throttle body. <Ref. to FU(H4SO)-10, INSTALLATION, Throttle Body.>

17) Install the pitching stopper.

Tightening torque:

T1: 50 N·m (5.1 kgf-m, 37 ft-lb)

T2: 58 N·m (5.9 kgf-m, 43 ft-lb)

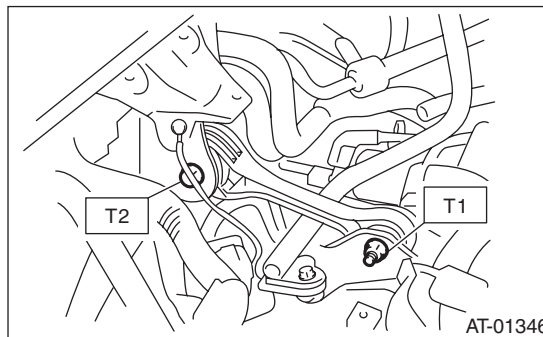

AT-01346

18) Lift-up the vehicle.

19) Replace the circlip of the front drive shaft with a new part.

20) Apply grease to the oil seal lip.

Automatic Transmission Assembly

AUTOMATIC TRANSMISSION

- 21) Attach the ST to side retainer.
ST 28399SA010 OIL SEAL PROTECTOR

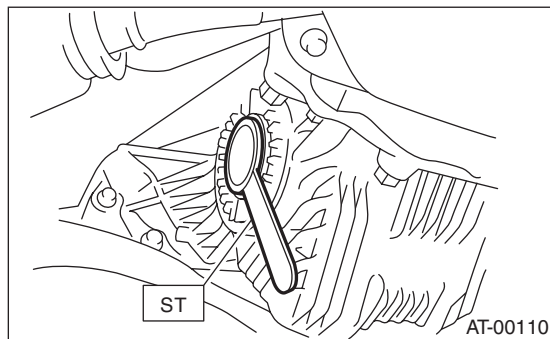

- 22) Align and insert the spline of the front drive shaft to the splines of the differential bevel gear, and remove the ST.

ST 28399SA010 OIL SEAL PROTECTOR

- 23) Insert the front drive shaft into the transmission securely by pressing the front housing from the outside.

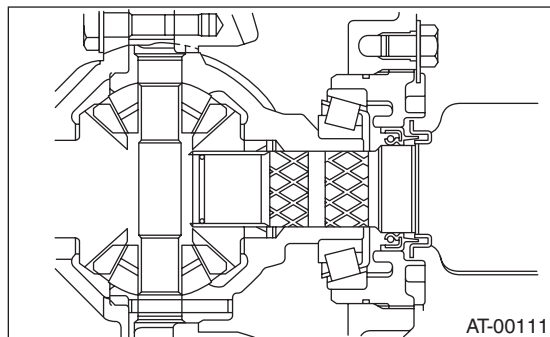

- 24) Install the ball joint into the housing.
25) Tighten the attachment bolts.

Tightening torque:
50 N·m (5.1 kgf·m, 36.9 ft·lb)

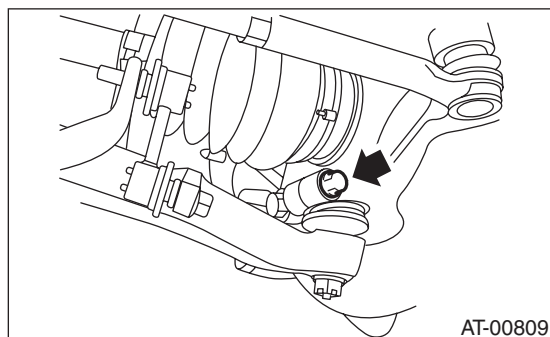

- 26) Install the stabilizer to the crossmember.

NOTE:

- Install the bushing (on front crossmember side) while aligning it with the paint mark on the stabilizer.
- Make sure the bushing and stabilizer are marked with the same identification colors (paint mark) when installing.

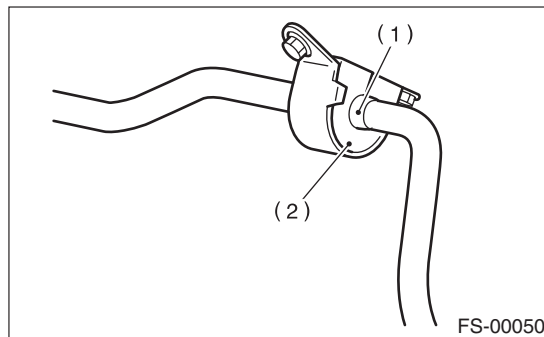

- (1) Identification mark on stabilizer
(2) Bushing identification color

- 27) Always tighten the rubber bushing locations with wheels in full contact with the ground and the vehicle at curb weight.

Tightening torque:

25 N·m (2.5 kgf·m, 18 ft·lb)

- 28) Install the shift select cable onto select lever.
<Ref. to CS-25, INSTALLATION, Select Cable.>
29) Install the oil charge pipe, and connect the ATF cooler hoses to the pipe.

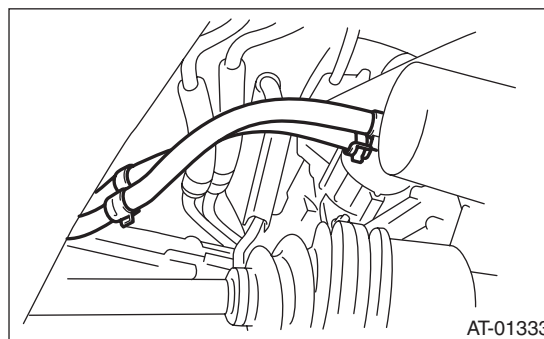

- 30) Install the propeller shaft.
<Ref. to DS-11, INSTALLATION, Propeller Shaft.>
31) Install the heat shield cover.

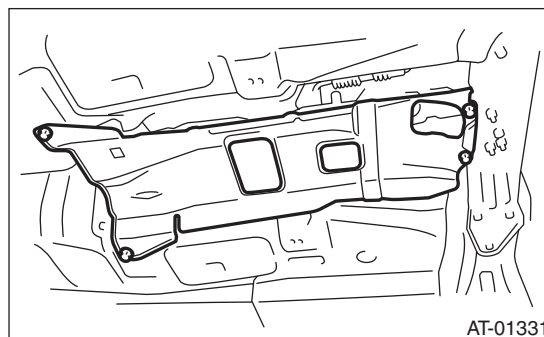

32) Install the rear exhaust pipe and muffler assembly.

<Ref. to EX(H4SO)-8, INSTALLATION, Rear Exhaust Pipe.> <Ref. to EX(H4SO)-10, INSTALLATION, Muffler.>

33) Install the front and center exhaust pipe.

<Ref. to EX(H4SO)-5, INSTALLATION, Front Exhaust Pipe.>

34) Install the under cover.

35) Lower the lift.

36) Install the ATF level gauge.

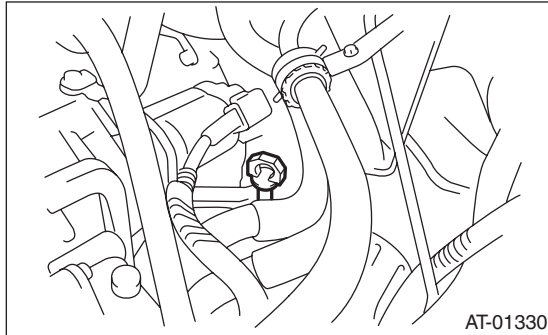

37) Connect the following connectors.

- (1) Transmission harness connectors
- (2) Transmission ground terminal

38) Install the air cleaner case stay.

Tightening torque:

16 N·m (1.6 kgf·m, 11.6 ft·lb)

39) Install the air intake chamber.

<Ref. to IN(H4SO)-7, INSTALLATION, Air Intake Chamber.>

40) Install the air intake duct.

<Ref. to IN(H4SO)-8, INSTALLATION, Air Intake Duct.>

41) From the gauge hole, add ATF until the fluid level is between the upper and lower level on the "COLD" side of the level gauge. <Ref. to 4AT-26, Automatic Transmission Fluid.>

42) Take off the vehicle from lift.

43) Check the differential gear oil level. <Ref. to 4AT-28, Differential Gear Oil.>

44) Check the select lever operation.

<Ref. to 4AT-46, INSPECTION, Inhibitor Switch.>

45) Bleed the air of control valve. <Ref. to 4AT-60, Air Bleeding of Control Valve.>

46) Check the ATF level. <Ref. to 4AT-26, Automatic Transmission Fluid.>

47) Execute the learning control promotion. <Ref. to 4AT(diag)-16, FACILITATION OF LEARNING CONTROL, OPERATION, Subaru Select Monitor.>

48) Perform the road test.

<Ref. to 4AT-29, Road Test.>