

15. Rear Vehicle Speed Sensor

A: REMOVAL

- 1) Set the vehicle on a lift.
- 2) Disconnect the ground cable from the battery.
- 3) Remove the intercooler. (Turbo model)
<Ref. to IN(H4DOTC)-12, REMOVAL, Intercooler.>
- 4) Remove the air intake chamber. (Non-turbo model)
<Ref. to IN(H6DO)-7, REMOVAL, Air Intake Chamber.>
- 5) Disconnect the following connectors.

- Turbo model

1. Transmission harness connectors

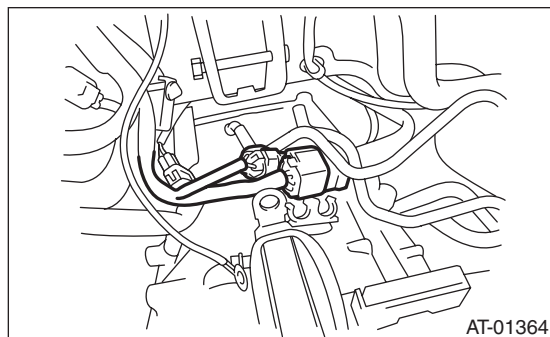

2. Front oxygen (A/F) sensor

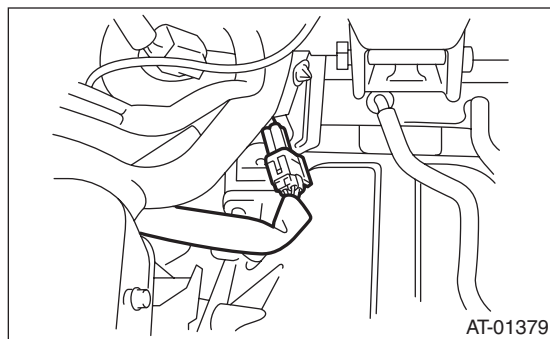

- Non-turbo model

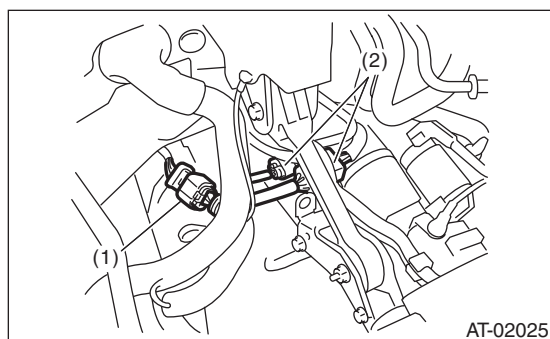

- (1) Front oxygen (A/F) sensor
- (2) Transmission harness connectors

- 6) Remove the transmission harness connector and front oxygen (A/F) sensor connector from the stay.

- 7) Lift-up the vehicle.
- 8) Clean the transmission exterior.
- 9) Drain the ATF completely. <Ref. to 5AT-26, REPLACEMENT, Automatic Transmission Fluid.>
- 10) Remove the center and rear exhaust pipes and the muffler. (Turbo model) <Ref. to EX(H4DOTC)-8, REMOVAL, Center Exhaust Pipe.> <Ref. to EX(H4DOTC)-12, REMOVAL, Rear Exhaust Pipe.> <Ref. to EX(H4DOTC)-13, REMOVAL, Muffler.>
- 11) Remove the rear exhaust pipe and muffler. (Non-turbo model) <Ref. to EX(H6DO)-7, REMOVAL, Rear Exhaust Pipe.> <Ref. to EX(H6DO)-9, REMOVAL, Muffler.>
- 12) Remove the heat shield cover.
- 13) Remove the propeller shaft. <Ref. to DS-10, REMOVAL, Propeller Shaft.>
- 14) Place the transmission jack under the transmission.

NOTE:

Make sure that the support plate of transmission jack does not touch the cross.

- 15) Remove the transmission rear crossmember bolt.

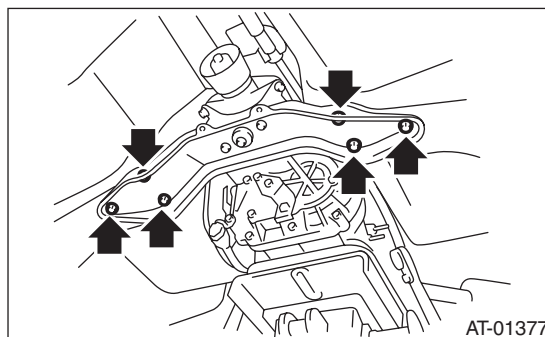

- 16) Lower the transmission jack.

NOTE:

Do not separate the transmission jack and transmission.

- 17) Remove the oil charge pipe. <Ref. to 5AT-62, REMOVAL, Oil Charge Pipe.>
- 18) Remove the ATF cooler inlet and outlet pipes.

NOTE:

When removing the outlet pipe, be careful not to lose the ball and spring used with retaining screw.

Rear Vehicle Speed Sensor

AUTOMATIC TRANSMISSION

19) Disconnect the connector from turbine speed sensor 1.

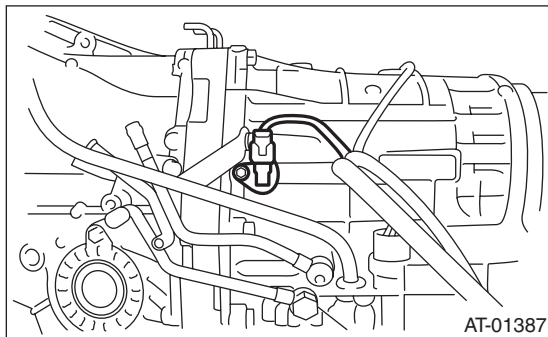

20) Remove the rear vehicle speed sensor.

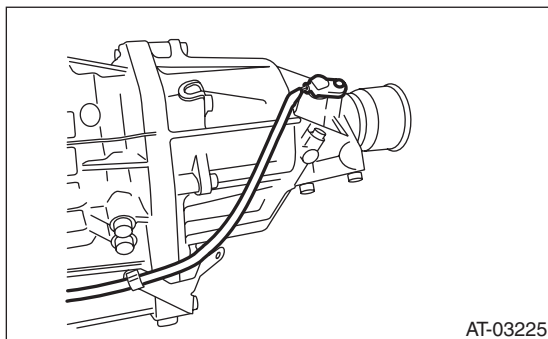

21) Remove the oil pan.

22) Disconnect the control valve connector and front vehicle speed sensor connector.

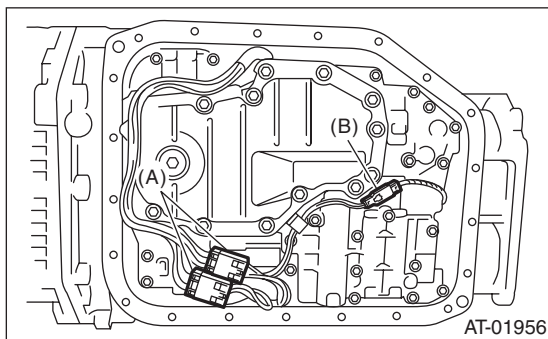

- (A) Control valve connector
- (B) Front vehicle speed sensor connector

23) Remove the control valve body.

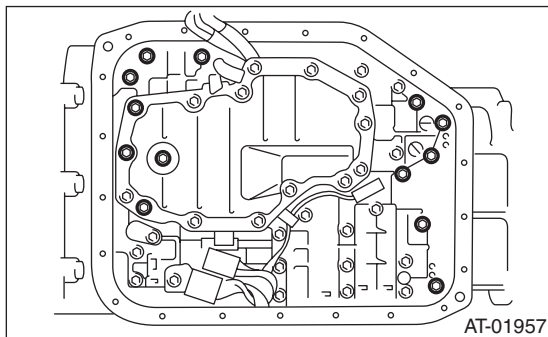

24) Remove the bolt securing harness of transmission main case.

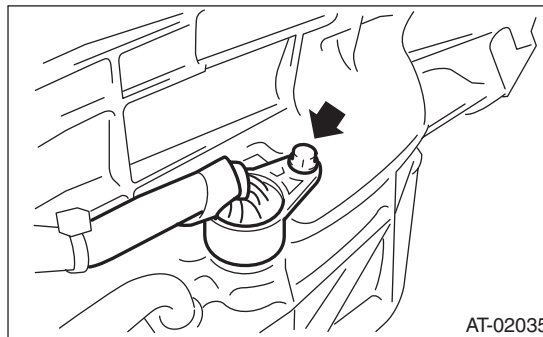

25) Remove the harness assembly.

B: INSTALLATION

1) Pass the harness assembly through the hole in transmission case.

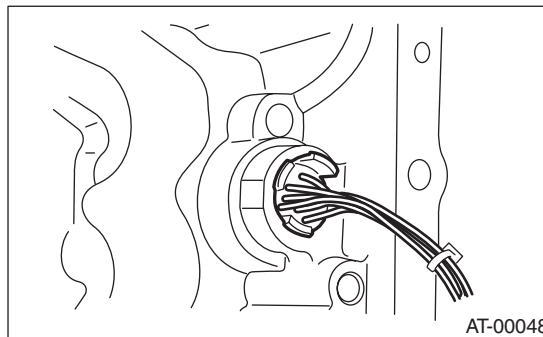

2) Install the securing bolt of transmission main case.

Tightening torque:
7 N·m (0.7 kgf·m, 5.2 ft·lb)

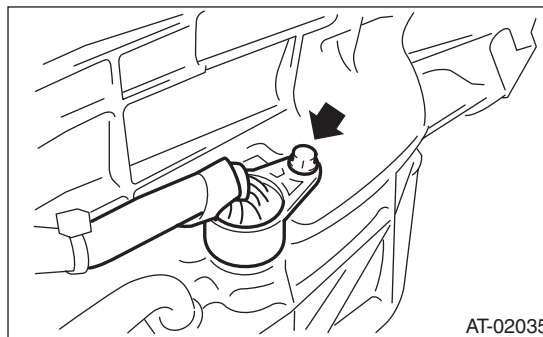

3) Install the control valve body.

Tightening torque:

8 N·m (0.8 kgf·m, 5.8 ft·lb)

NOTE:

Be careful not to catch harness in.

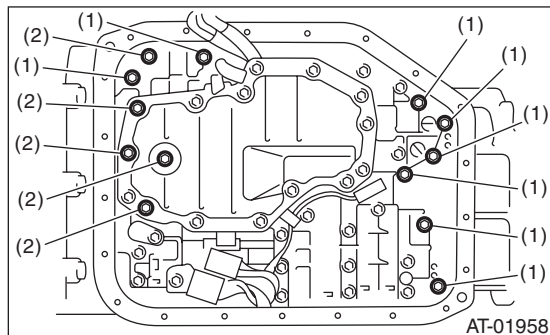

(1) 58 mm (2.28 in)

(2) 65 mm (2.56 in)

4) Connect the control valve connector and front vehicle speed sensor connector.

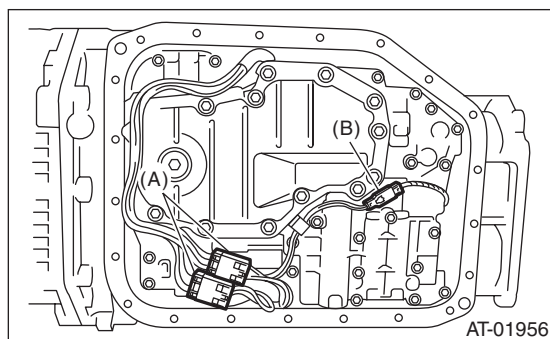

(A) Control valve connector

(B) Front vehicle speed sensor connector

5) Apply proper amount of liquid gasket to the entire oil pan mating surface.

Liquid gasket:

THREE BOND 1217B (Part No. K0877YA020)

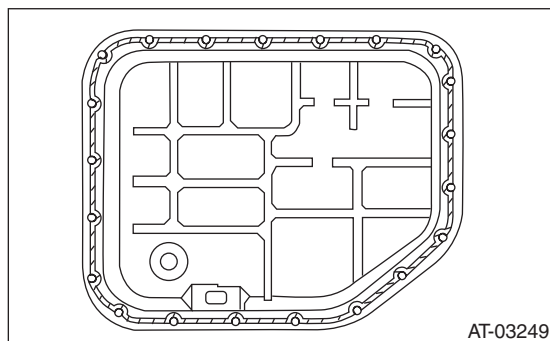

6) Install the oil pan by equally tightening the bolts.

Tightening torque:

5 N·m (0.5 kgf·m, 3.7 ft·lb)

7) Install the rear vehicle speed sensor and turbine speed sensor 1, and then fasten the harness.

Tightening torque:

7 N·m (0.7 kgf·m, 5.2 ft·lb)

8) Install a new aluminum washer and oil cooler pipe.

Tightening torque:

40 N·m (4.1 kgf·m, 29.51 ft·lb) (ATF inlet pipe)

45 N·m (4.6 kgf·m, 33.2 ft·lb) (ATF outlet pipe)

9) Install the oil charge pipe. <Ref. to 5AT-62, INSTALLATION, Oil Charge Pipe.>

10) Install the transmission rear crossmember bolt.

Tightening torque:

70 N·m (7.1 kgf·m, 51.6 ft·lb)

11) Install the propeller shaft. <Ref. to DS-11, INSTALLATION, Propeller Shaft.>

12) Install the heat shield cover.

13) Install the center, rear exhaust pipes and the muffler. (Turbo model)

<Ref. to EX(H4DOTC)-9, INSTALLATION, Center Exhaust Pipe.> <Ref. to EX(H4DOTC)-12, INSTALLATION, Rear Exhaust Pipe.> <Ref. to EX(H4DOTC)-13, INSTALLATION, Muffler.>

14) Install the rear exhaust pipe and muffler. (Non-turbo model) <Ref. to EX(H6DO)-7, INSTALLATION, Rear Exhaust Pipe.> <Ref. to EX(H6DO)-9, INSTALLATION, Muffler.>

15) Lower the vehicle.

16) Install the transmission connector to the stay, and then connect the connector.

17) Install the intercooler. (Turbo model) <Ref. to IN(H4DOTC)-12, INSTALLATION, Intercooler.>

18) Install the air intake chamber. (Non-turbo model) <Ref. to IN(H6DO)-7, INSTALLATION, Air Intake Chamber.>

19) Pour ATF from the oil charge pipe. <Ref. to 5AT-26, REPLACEMENT, Automatic Transmission Fluid.>

20) Check the level and leaks of ATF. <Ref. to 5AT-26, INSPECTION, Automatic Transmission Fluid.>

21) Execute the learning control promotion. <Ref. to 5AT(diag)-22, PROCEDURE, Learning Control.>