

Diagnostic Procedure without Diagnostic Trouble Code (DTC)

AUTOMATIC TRANSMISSION (DIAGNOSTICS)

14. Diagnostic Procedure without Diagnostic Trouble Code (DTC)

A: CHECK FWD SWITCH

DIAGNOSIS:

- LED does not come on even if FWD switch is ON.
- FWD signal circuit is open or shorted.

WIRING DIAGRAM:

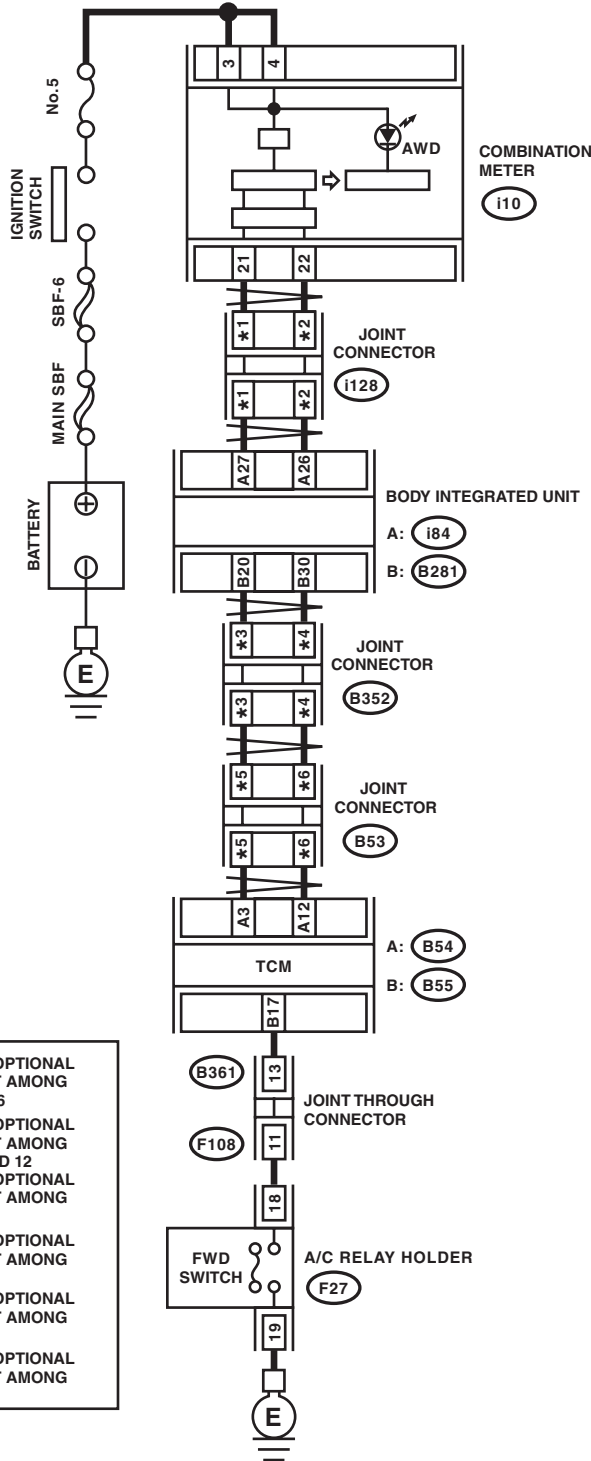

- *1 : TERMINAL No. OPTIONAL ARRANGEMENT AMONG 1, 2, 3, 4, 5 AND 6
- *2 : TERMINAL No. OPTIONAL ARRANGEMENT AMONG 7, 8, 9, 10, 11 AND 12
- *3 : TERMINAL No. OPTIONAL ARRANGEMENT AMONG 1, 2, 5 AND 6
- *4 : TERMINAL No. OPTIONAL ARRANGEMENT AMONG 3, 4, 7 AND 8
- *5 : TERMINAL No. OPTIONAL ARRANGEMENT AMONG 8, 18 AND 19
- *6 : TERMINAL No. OPTIONAL ARRANGEMENT AMONG 9, 10 AND 20

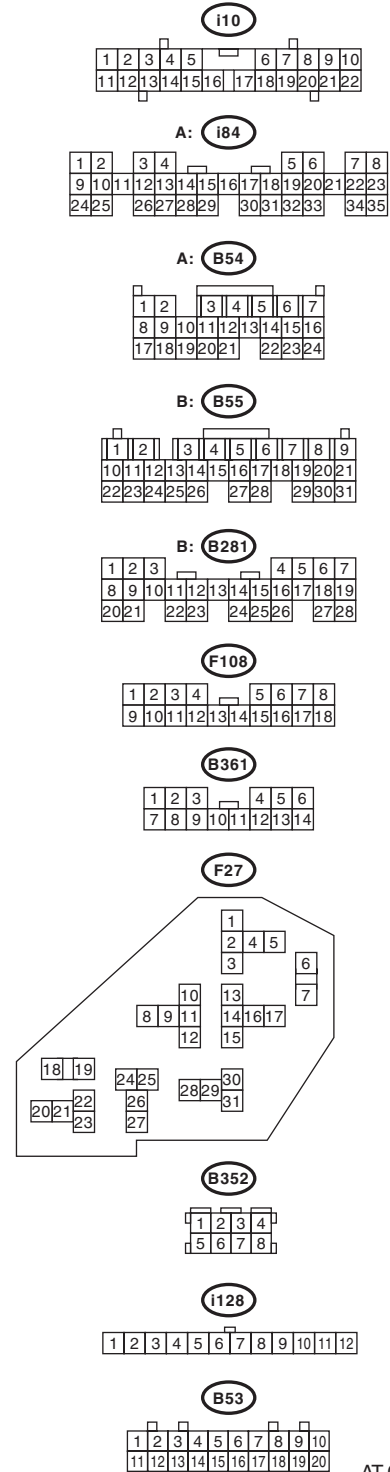

AT-03568

Diagnostic Procedure without Diagnostic Trouble Code (DTC)

AUTOMATIC TRANSMISSION (DIAGNOSTICS)

Step	Check	Yes	No	
1	CHECK SPARE FUSE.	Is the spare fuse OK?	Go to step 2.	Replace the fuse.
2	CHECK FWD SWITCH. Connect the Subaru Select Monitor to the data link connector.	When the fuse is inserted to FWD switch, does the LED illuminate?	Go to step 3.	Go to step 4.
3	CHECK COMBINATION METER.	Does the AWD warning light illuminate?	Go to INSPECTION FOR SPORT SHIFT SWITCH. <Ref. to 4AT(diag)-93, CHECK SPORT SHIFT SWITCH, Diagnostic Procedure without Diagnostic Trouble Code (DTC).>	Go to step 9.
4	CHECK HARNESS CONNECTOR BETWEEN TCM AND FWD SWITCH. 1) Turn the ignition switch to OFF. 2) Disconnect the connector from TCM. 3) Measure the resistance of harness between TCM and FWD switch connector. Connector & terminal (B55) No. 17 — (F27) No. 18:	Is the resistance less than 1 Ω ?	Go to step 5.	Repair the open circuit of harness between TCM and FWD switch connectors.
5	CHECK HARNESS CONNECTOR BETWEEN FWD SWITCH AND CHASSIS GROUND. Measure the resistance of harness between FWD switch and chassis ground. Connector & terminal (F27) No. 19 — Chassis ground:	Is the resistance less than 1 Ω ?	Go to step 6.	Repair the open circuit of harness between FWD switch connector and chassis ground.
6	CHECK HARNESS CONNECTOR BETWEEN TCM AND FWD SWITCH. Measure the resistance of harness connector between TCM and body to make sure that circuit does not short. Connector & terminal (B55) No. 17 — Chassis ground:	Is the resistance more than 1 $M\Omega$?	Go to step 7.	Repair the short circuit of harness between TCM and FWD switch connectors.
7	CHECK INPUT SIGNAL FOR TCM. 1) Turn the ignition switch to OFF. 2) Connect the connector to TCM. 3) Turn the ignition switch to ON. 4) Measure the signal voltage for TCM while installing the fuse to FWD switch connector. Connector & terminal (B55) No. 17 (+) — Chassis ground (-):	Is the voltage less than 1 V?	Go to step 8.	Go to step 10.
8	CHECK INPUT SIGNAL FOR TCM. Measure the signal voltage for TCM with the fuse removed from FWD switch connector. Connector & terminal (B55) No. 17 (+) — Chassis ground (-):	Is the voltage more than 10.5 V?	Go to step 9.	Replace the TCM. <Ref. to 4AT-62, Transmission Control Module (TCM).>
9	CHECK THE BODY INTEGRATED UNIT. Check DTC of body integrated unit.	Is DTC of CAN communication displayed?	Perform the diagnosis according to DTC.	Go to step 10.
10	CHECK COMBINATION METER. Check the AWD warning light. <Ref. to IDI-3, INSPECTION, Combination Meter System.>	Is the AWD warning light OK?	Go to step 11.	Replace the combination meter assembly. <Ref. to IDI-14, Combination Meter.>

Diagnostic Procedure without Diagnostic Trouble Code (DTC)

AUTOMATIC TRANSMISSION (DIAGNOSTICS)

	Step	Check	Yes	No
11	CHECK POOR CONTACT.	Is there poor contact in FWD switch circuit?	Repair the poor contact.	Replace the TCM. <Ref. to 4AT-62, Transmission Control Module (TCM).>

Diagnostic Procedure without Diagnostic Trouble Code (DTC)

AUTOMATIC TRANSMISSION (DIAGNOSTICS)

B: CHECK SPORT SHIFT SWITCH

DIAGNOSIS:

Input signal circuit of SPORT shift switch is open or shorted.

TROUBLE SYMPTOM:

Does not shift on manual mode.

WIRING DIAGRAM:

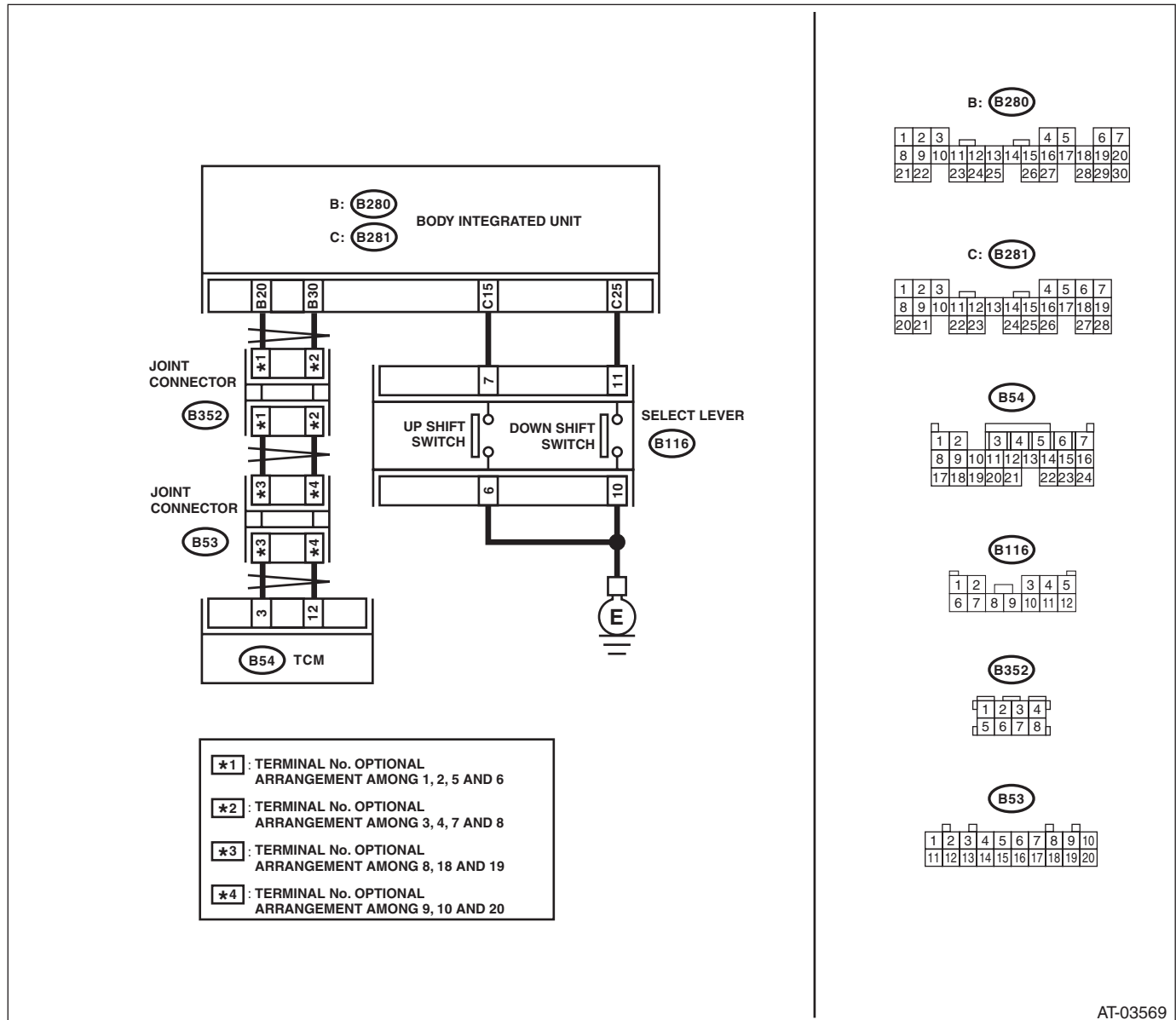

AT-03569

Diagnostic Procedure without Diagnostic Trouble Code (DTC)

AUTOMATIC TRANSMISSION (DIAGNOSTICS)

Step	Check	Yes	No
1 CHECK SPORT SHIFT SWITCH. 1) Move the select lever to SPORT mode. 2) Shift and hold the select lever to up side. 3) Read the "Up Switch" data of TCM using Subaru Select Monitor. <Ref. to 4AT(diag)-15, READ CURRENT DATA, OPERATION, Subaru Select Monitor.>	Is ON displayed?	Go to step 2.	Go to step 3.
2 CHECK SPORT SHIFT SWITCH. 1) Shift and hold the select lever to down side. 2) Read the "Down Switch" data of TCM using Subaru Select Monitor.	Is ON displayed?	Go to the procedure "INSPECTION FOR SPORT SHIFT INDICATOR LIGHT". <Ref. to 4AT(diag)-97, CHECK SPORT SHIFT INDICATOR, Diagnostic Procedure without Diagnostic Trouble Code (DTC).>	Go to step 12.
3 CHECK THE BODY INTEGRATED UNIT. 1) Turn the ignition switch to ON. 2) Shift and hold the select lever to up side. 3) Read the "TIP UP SW" data of body integrated unit using Subaru Select Monitor. <Ref. to LAN(diag)-12, OPERATION, Subaru Select Monitor.>	Is ON displayed?	Go to step 4.	Go to step 5.
4 CHECK THE BODY INTEGRATED UNIT. Check DTC of body integrated unit. <Ref. to LAN(diag)-12, OPERATION, Subaru Select Monitor.>	Is DTC of CAN communication displayed?	Perform the diagnosis according to DTC.	Check the TCM.
5 CHECK SPORT SHIFT SWITCH GROUND CIRCUIT. 1) Turn the ignition switch to OFF. 2) Disconnect the connector from SPORT shift switch. 3) Measure the resistance of harness between SPORT shift switch connector and chassis ground. Connector & terminal (B116) No. 6 — Chassis ground:	Is the resistance less than 1 Ω ?	Go to step 6.	Repair the open circuit of harness between SPORT shift switch and chassis ground.
6 CHECK SPORT SHIFT SWITCH. Measure the resistance between SPORT shift switch terminals. Connector & terminal (B116) No. 6 — No. 7:	Is the resistance more than 1 M Ω ?	Go to step 7.	Replace the guide plate assembly.
7 CHECK SPORT SHIFT SWITCH. 1) Shift and hold the select lever to up side. 2) Measure the resistance between SPORT shift switch terminals. Connector & terminal (B116) No. 6 — No. 7:	Is the resistance less than 1 Ω ?	Go to step 8.	Replace the guide plate assembly.

Diagnostic Procedure without Diagnostic Trouble Code (DTC)

AUTOMATIC TRANSMISSION (DIAGNOSTICS)

Step	Check	Yes	No
8 CHECK HARNESS CONNECTOR BETWEEN BODY INTEGRATED UNIT AND SPORT SHIFT SWITCH. 1) Disconnect the connector from body integrated unit. 2) Measure the resistance of harness between body integrated unit connector and SPORT shift switch connector. Connector & terminal (B116) No. 7 — (B281) No. 15:	Is the resistance less than 1 Ω ?	Go to step 9.	Repair the open circuit of harness between SPORT shift switch connector and TCM connector, or poor contact in connector.
9 CHECK HARNESS CONNECTOR BETWEEN TCM AND SPORT SHIFT SWITCH. Measure the resistance of harness between SPORT shift switch connector and chassis ground. Connector & terminal (B116) No. 7 — Chassis ground:	Is the resistance more than 1 $M\Omega$?	Go to step 10.	Repair the short circuit of harness between SPORT shift switch connector and TCM connector.
10 CHECK INPUT SIGNAL TO BODY INTEGRATED UNIT. 1) Connect all connectors. 2) Turn the ignition switch to ON (engine OFF). 3) Check the signal voltage for body integrated unit. Connector & terminal (B281) No. 15 (+) — Chassis ground (-):	Is the voltage 1.5 — 8 V?	Go to step 11.	Replace the body integrated unit.
11 CHECK INPUT SIGNAL TO BODY INTEGRATED UNIT. 1) Shift and hold the select lever to up side. 2) Check the signal voltage for body integrated unit. Connector & terminal (B281) No. 15 (+) — Chassis ground (-):	Is the voltage less than 1 V?	Go to step 21.	Replace the body integrated unit.
12 CHECK THE BODY INTEGRATED UNIT. 1) Turn the ignition switch to ON. 2) Shift and hold the select lever to down side. 3) Read the "TIP DOWN SW" data of body integrated unit using Subaru Select Monitor. <Ref. to LAN(diag)-12, OPERATION, Subaru Select Monitor.>	Is ON displayed?	Go to step 13.	Go to step 14.
13 CHECK THE BODY INTEGRATED UNIT. Check DTC of body integrated unit.	Is DTC of CAN communication displayed?	Perform the diagnosis according to DTC.	Check the TCM.
14 CHECK SPORT SHIFT SWITCH GROUND CIRCUIT. 1) Turn the ignition switch to OFF. 2) Disconnect the connector from SPORT shift switch. 3) Measure the resistance of harness between SPORT shift switch connector and chassis ground. Connector & terminal (B116) No. 10 (+) — Chassis ground:	Is the resistance less than 1 Ω ?	Go to step 15.	Repair the open circuit of harness between SPORT shift switch and chassis ground.
15 CHECK SPORT SHIFT SWITCH. Measure the resistance between SPORT shift switch terminals. Connector & terminal (B116) No. 10 — No. 11:	Is the resistance more than 1 $M\Omega$?	Go to step 16.	Replace the guide plate assembly.

Diagnostic Procedure without Diagnostic Trouble Code (DTC)

AUTOMATIC TRANSMISSION (DIAGNOSTICS)

Step	Check	Yes	No
16 CHECK SPORT SHIFT SWITCH. 1) Shift and hold the select lever to down side. 2) Measure the resistance between SPORT shift switch terminals. Connector & terminal (B116) No. 10 — No. 11:	Is the resistance less than 1 Ω ?	Go to step 17.	Replace the guide plate assembly.
17 CHECK HARNESS CONNECTOR BETWEEN BODY INTEGRATED UNIT AND SPORT SHIFT SWITCH. 1) Disconnect the connector from body integrated unit. 2) Measure the resistance of harness between body integrated unit connector and SPORT shift switch connector. Connector & terminal (B116) No. 11 — (B281) No. 25:	Is the resistance less than 1 Ω ?	Go to step 18.	Repair the open circuit of harness between SPORT shift switch connector and TCM connector, or poor contact in connector.
18 CHECK HARNESS CONNECTOR BETWEEN BODY INTEGRATED UNIT AND SPORT SHIFT SWITCH. Measure the resistance of harness between SPORT shift switch connector and chassis ground. Connector & terminal (B116) No. 11 — Chassis ground:	Is the resistance more than 1 M Ω ?	Go to step 19.	Repair the short circuit of harness between SPORT shift switch connector and TCM connector.
19 CHECK INPUT SIGNAL TO BODY INTEGRATED UNIT. 1) Connect all connectors. 2) Turn the ignition switch to ON (engine OFF). 3) Check the signal voltage for body integrated unit. Connector & terminal (B281) No. 25 (+) — Chassis ground (-):	Is the voltage 1.5 — 8 V?	Go to step 20.	Go to step 21.
20 CHECK INPUT SIGNAL TO BODY INTEGRATED UNIT. 1) Shift and hold the select lever to down side. 2) Check the signal voltage for body integrated unit. Connector & terminal (B281) No. 25 (+) — Chassis ground (-):	Is the voltage less than 1 V?	Go to step 21.	Replace the body integrated unit. <Ref. to 4AT-62, Transmission Control Module (TCM).>
21 CHECK POOR CONTACT.	Is there poor contact in the SPORT shift switch circuit?	Repair the poor contact.	A temporary poor contact of the SPORT shift switch circuit connector or harness.

Diagnostic Procedure without Diagnostic Trouble Code (DTC)

AUTOMATIC TRANSMISSION (DIAGNOSTICS)

C: CHECK SPORT SHIFT INDICATOR

DIAGNOSIS:

Output signal circuit of SPORT shift indicator is open or shorted.

TROUBLE SYMPTOM:

- SPORT shift indicator does not display or remains displayed.
- SPORT shift indicator display does not change.

WIRING DIAGRAM:

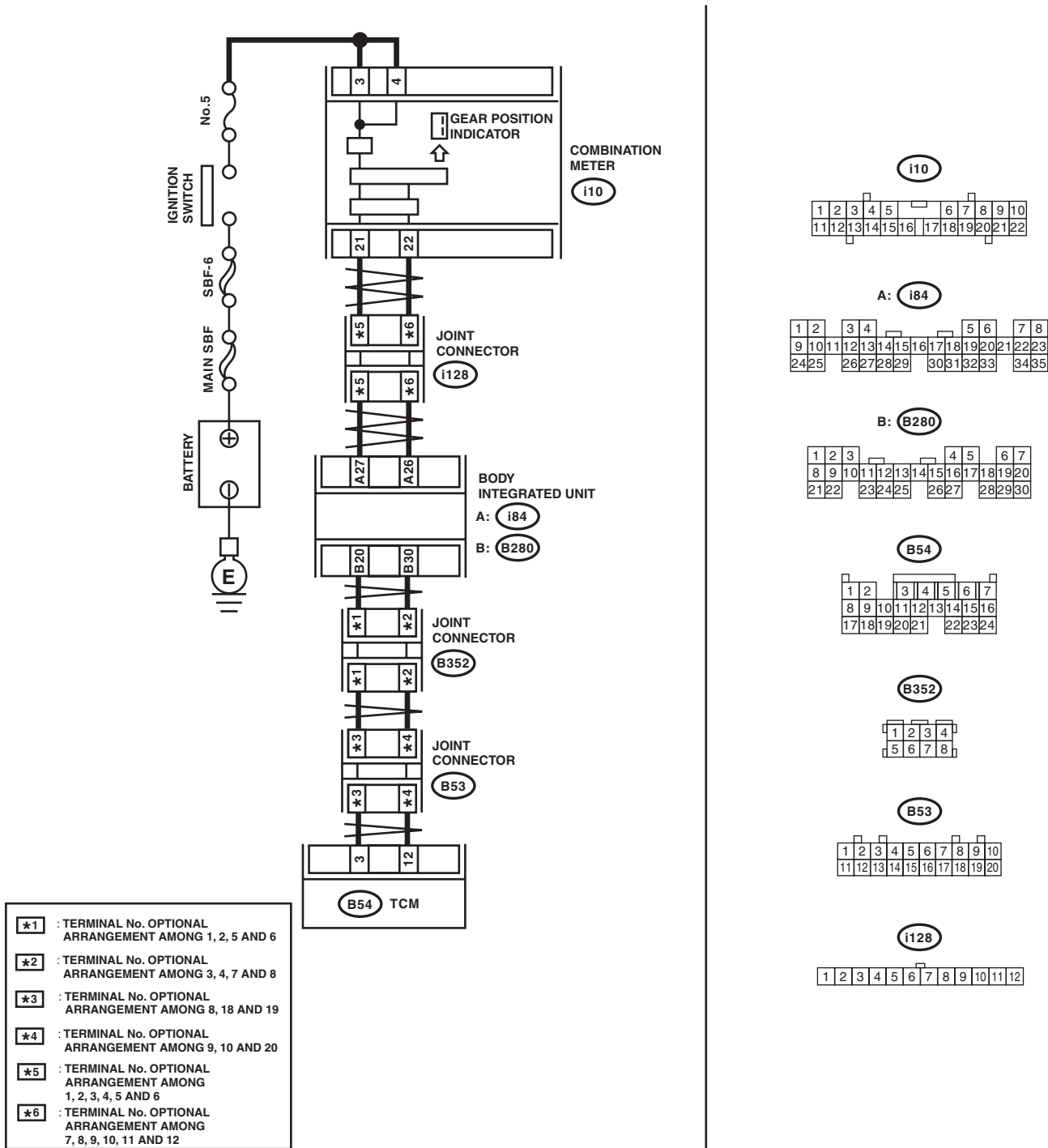

Diagnostic Procedure without Diagnostic Trouble Code (DTC)

AUTOMATIC TRANSMISSION (DIAGNOSTICS)

Step	Check	Yes	No	
1	CHECK THE BODY INTEGRATED UNIT. Check DTC of body integrated unit.	Is DTC of CAN communication displayed?	Perform the diagnosis according to DTC.	Go to step 2.
2	CHECK TCM. 1) Turn the ignition switch to OFF. 2) Connect the Subaru Select Monitor to the data link connector. 3) Turn the ignition switch to ON. (engine OFF) 4) Turn the Subaru Select Monitor switch to ON. 5) Shift the select lever to SPORT mode. 6) Up-shift the select lever. 7) Read the "Gear Position" data of TCM using Subaru Select Monitor.	Is the gear position 2?	Go to step 3.	Replace the TCM. <Ref. to 4AT-62, Transmission Control Module (TCM).>
3	CHECK TCM. 1) Down-shift the select lever. 2) Read the "Gear Position" data of TCM using Subaru Select Monitor.	Is the gear position 1?	Go to step 4.	Replace the TCM. <Ref. to 4AT-62, Transmission Control Module (TCM).>
4	CHECK THE BODY INTEGRATED UNIT. Read the data of SPORT shift gear position using Subaru Select Monitor.	Is the SPORT shift gear position 2?	Go to step 5.	Check the body integrated unit.
5	CHECK COMBINATION METER. <Ref. to IDI-3, INSPECTION, Combination Meter System.>	Is the SPORT shift indicator OK?	INSPECTION OF BUZZER <Ref. to 4AT(diag)-101, Diagnostics with Phenomenon.>	Replace the combination meter assembly. <Ref. to IDI-14, Combination Meter.>

Diagnostic Procedure without Diagnostic Trouble Code (DTC)

AUTOMATIC TRANSMISSION (DIAGNOSTICS)

D: CHECK BUZZER

DIAGNOSIS:

Output signal circuit of buzzer is open or shorted.

TROUBLE SYMPTOM:

Buzzer remains beeping.

WIRING DIAGRAM:

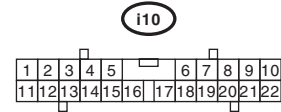
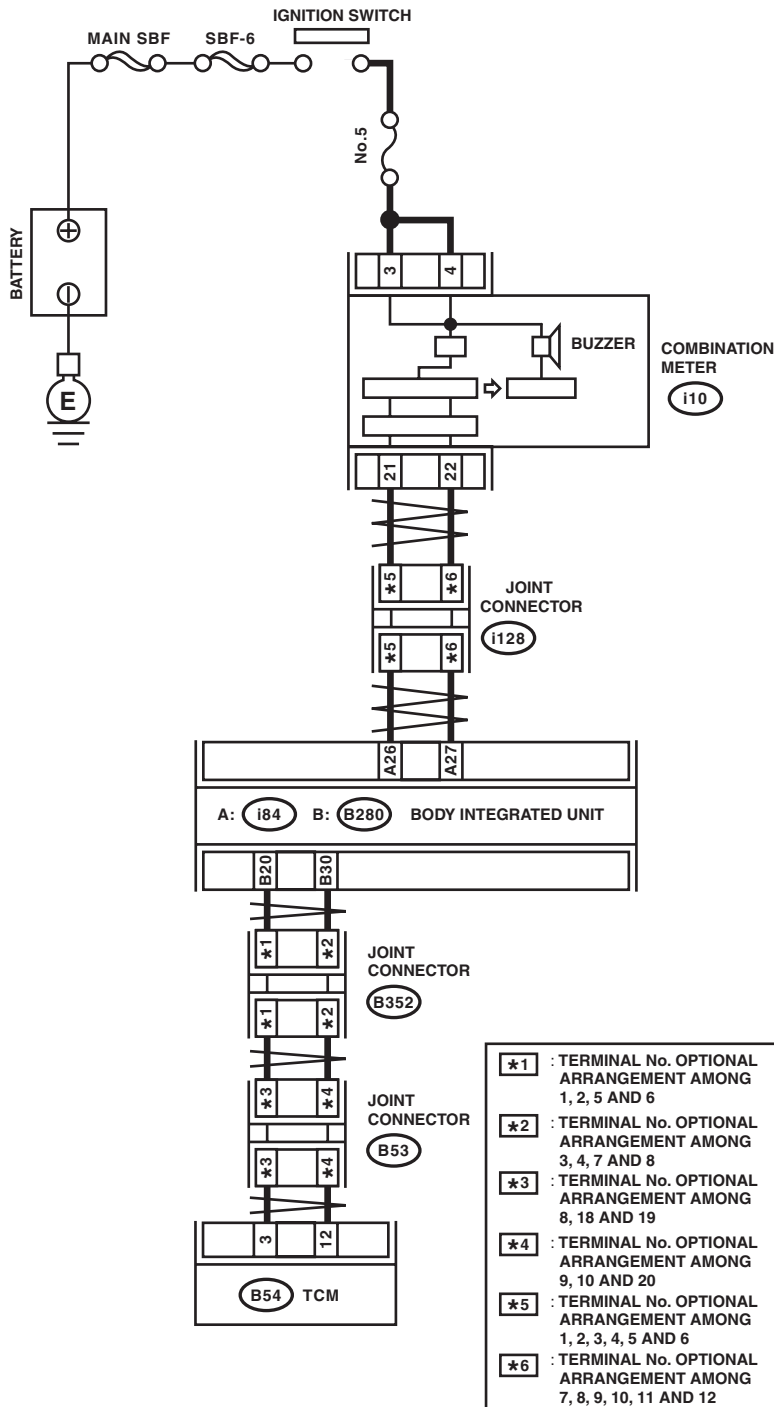

A: i84

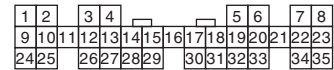

B: B280

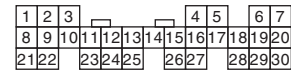

B54

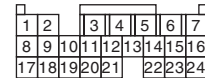

B352

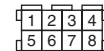

B53

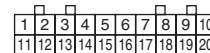

i128

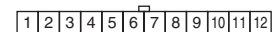

AT-03571

Diagnostic Procedure without Diagnostic Trouble Code (DTC)

AUTOMATIC TRANSMISSION (DIAGNOSTICS)

Step	Check	Yes	No
1 CHECK THE BODY INTEGRATED UNIT. 1) Turn the ignition switch to OFF. 2) Connect the Subaru Select Monitor to the data link connector. 3) Turn the ignition switch to ON. (engine OFF) 4) Turn the Subaru Select Monitor switch to ON. 5) Read the data of "SPORT shift (buzzer)" of body integrated unit using Subaru Select Monitor.	Is the SPORT shift buzzer display "ON"?	Replace the TCM. <Ref. to 4AT-62, Transmission Control Module (TCM).>	Go to step 2.
2 CHECK COMBINATION METER. <Ref. to IDI-3, INSPECTION, Combination Meter System.>	Is the buzzer OK?	Perform Diagnostics with Phenomenon. <Ref. to 4AT(diag)-101, Diagnostics with Phenomenon.>	Replace the combination meter assembly. <Ref. to IDI-14, Combination Meter.>