

10. Clutch Pedal

A: REMOVAL

- 1) Disconnect the ground cable from the battery.
- 2) Remove the steering column. <Ref. to PS-17, REMOVAL, Tilt Steering Column.>
- 3) Disconnect the connectors of the stop light switch and clutch switch.
- 4) Remove the snap pins from clevis pins which secure the lever to the push rod and operating rod.
- 5) Pull out the clevis pins which secures the lever to the push rod and operating rod.

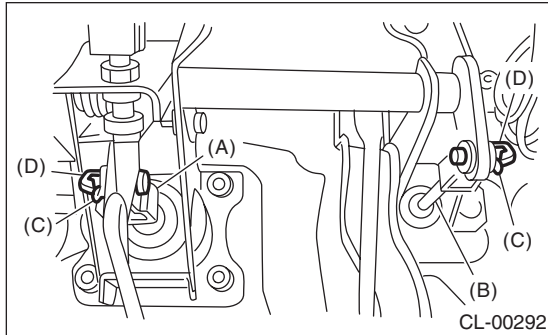

- (A) Operating rod
- (B) Push rod
- (C) Snap pin
- (D) Clevis pin

- 6) Remove the nut which secures the clutch master cylinder.

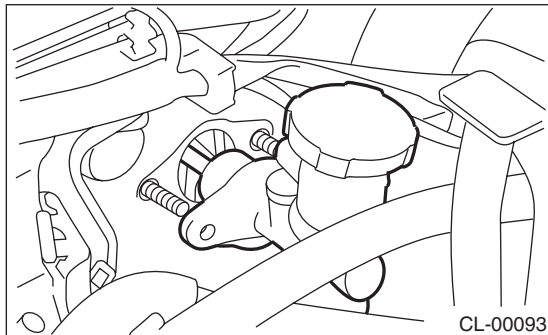

- 7) Remove the bolt which secures the brake pedal and clutch pedal, and remove the pedal assembly.

B: INSTALLATION

- 1) Install in the reverse order of removal.

Tightening torque:

T: 18 N·m (1.8 kgf·m, 13.0 ft·lb)

CAUTION:

Always use a new clevis pin.

- 2) Adjust the clutch pedal after installation. <Ref. to CL-24, ADJUSTMENT, Clutch Pedal.>

C: DISASSEMBLY

- 1) Remove the clutch switches.
- 2) Remove the clip, assist spring, rod and bushing.

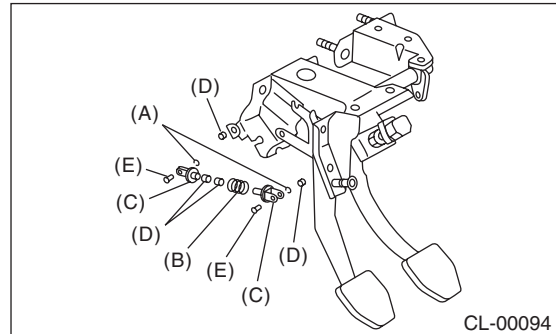

- (A) Clip
- (B) Assist spring
- (C) Assist rod
- (D) Bushing
- (E) Clevis pin

- 3) Extract the spring pin and remove the lever.

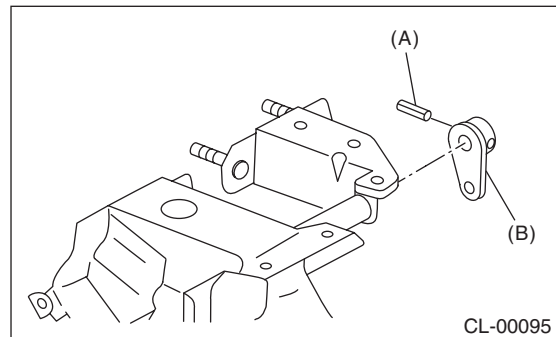

- (A) Pin
- (B) Lever

- 4) Remove the clutch pedal and bushing.

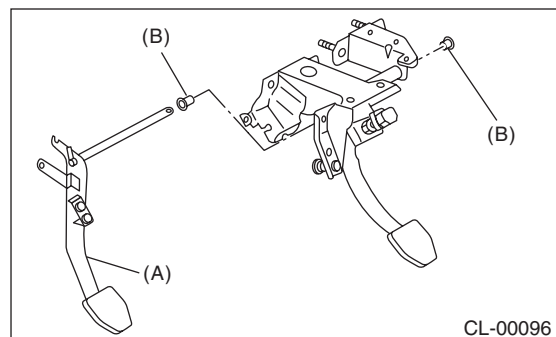

- (A) Clutch pedal
- (B) Bushing

Clutch Pedal

CLUTCH SYSTEM

5) Remove the stopper, clip and rod S, and remove the spring and bushing S.

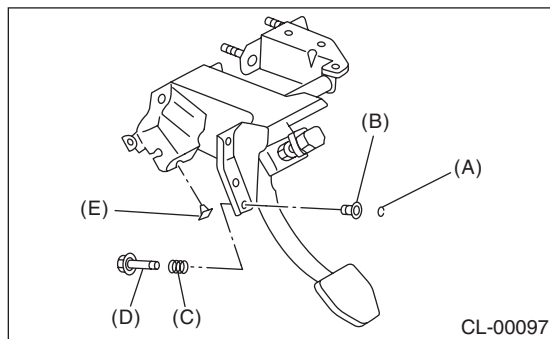

- (A) Clip
- (B) Bushing S
- (C) Spring S
- (D) Rod S
- (E) Stopper

6) Remove the stopper from the clutch pedal.

7) Remove the clutch pedal pad.

D: ASSEMBLY

1) Temporarily assemble the clutch switch, etc. to pedal bracket.

2) Clean the clutch pedal and brake pedal bushing holes, apply a thin coat of grease, and install the bushings.

3) Align the holes of the pedal bracket, clutch pedal and brake pedal, and install the brake pedal return spring, assist rod, spring and bushing.

NOTE:

Clean the inside of bushings and apply a thin coat of grease before installing the spacer.

E: INSPECTION

1. CLUTCH PEDAL

Move the clutch pedal pads in the lateral direction with a force of approximately 10 N (1 kgf, 2 lbf) to check that the clutch pedal deflection is within the service limit.

If it exceeds the service limit, replace with new bushings.

Deflection of the clutch pedal:

Service limit

5.0 mm (0.197 in) or less

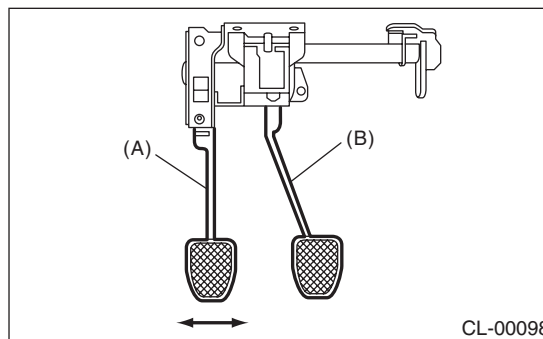

- (A) Clutch pedal
- (B) Brake pedal

F: ADJUSTMENT

1) Measure the full stroke of the clutch pedal.

NOTE:

- Measure the leading end of the seat cushion and center of the pedal.
- Align the seat with the seventh notch position from the position at the very front.

Specified clutch pedal full stroke A:

Non-turbo model:

130 — 135 mm (5.12 — 5.31 in)

Turbo model:

135 — 140 mm (5.31 — 5.51 in)

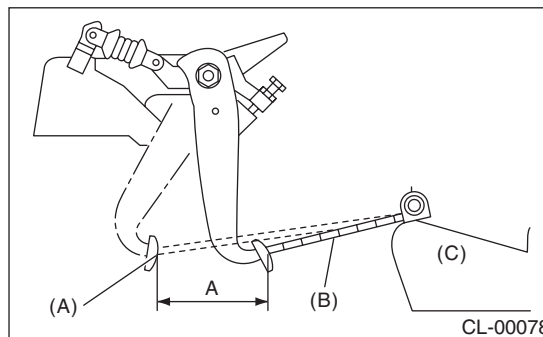

- (A) Clutch pedal (Full stroke condition)
- (B) Scale
- (C) Seat

2) If the full stroke is not within the specified value, loosen the clutch switch lock nut to adjust.

Tightening torque:

8 N·m (0.8 kgf·m, 5.8 ft·lb)

3) Loosen the push rod lock nuts.

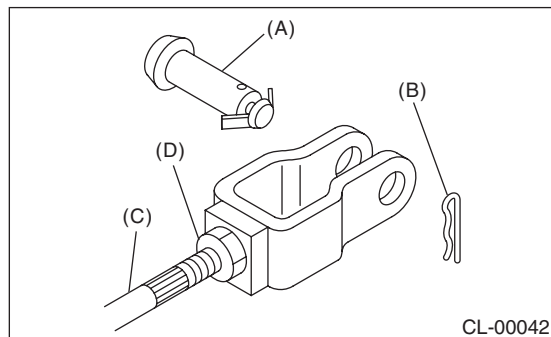

- (A) Clevis pin
- (B) Snap pin
- (C) Push rod
- (D) Push rod lock nut

4) Rotate the push rod to adjust.

(1) Make sure that the clutch pedal contacts the clutch switch side when the pedal is released.

(2) Make sure that the clutch pedal contacts the clutch pedal bracket stopper when the clutch pedal is at the maximum stroke position.

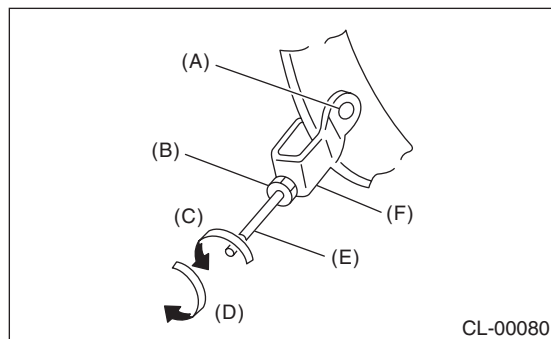

- (A) Clevis hole
- (B) Push rod lock nut
- (C) In the shorter direction
- (D) In the longer direction
- (E) Push rod
- (F) U shaped hardware

5) Turn the push rod to shorten until a clearance is gained on the clutch switch side.

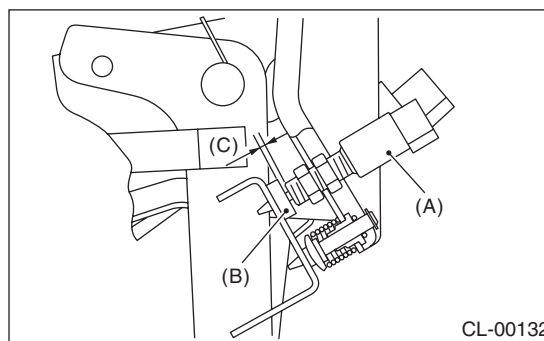

- (A) Clutch switch
- (B) Stopper
- (C) Clearance

6) Turn the push rod to lengthen until clutch pedal contacts the clutch switch.

7) Turn further in the direction that will shorten the push rod (arrow direction shown in figure) by 270°.

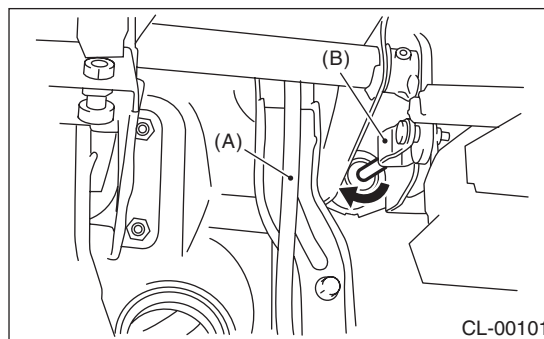

- (A) Accelerator pedal
- (B) Clevis

8) Check that the clevis pin moves smoothly by moving it in the left and right directions.

9) Tighten the push rod lock nut.

Tightening torque:

10 N·m (1.0 kgf·m, 7.2 ft·lb)

10) Depress and release the clutch pedal two or three times to ensure that the clutch pedal and release fork operate smoothly. If the clutch pedal and release fork do not operate smoothly, bleed air from the clutch hydraulic system. <Ref. to CL-22, Clutch Fluid Air Bleeding.>

Clutch Pedal

CLUTCH SYSTEM

11) Measure the clutch pedal full stroke length again to ensure that it is within specifications. If it is not within specifications, repeat adjustment procedures again from the beginning.

Specified clutch pedal full stroke:

Non-turbo model:

130 — 135 mm (5.12 — 5.31 in)

Turbo model:

135 — 140 mm (5.31 — 5.51 in)

12) Move the clevis pin to left, then to right. The clevis pin should move without resistance even if it is rattling. If resistance is felt, repeat adjustment procedures again from the beginning.

13) Push the release lever until the operating cylinder push rod retracts. Make sure that the clutch fluid level in the reservoir tank increases. If the clutch fluid level increases, the hydraulic clutch is properly adjusted; if the fluid level does not increase or the push rod does not retract, replace the master cylinder. <Ref. to CL-18, Master Cylinder.>

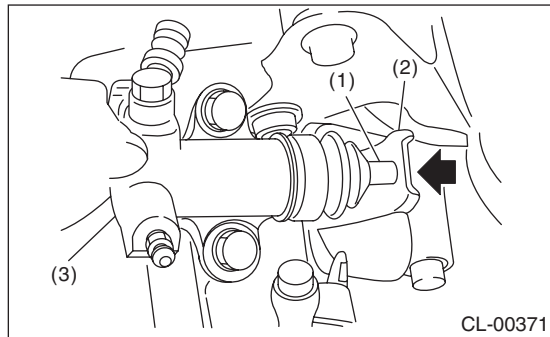

- (1) Push rod
- (2) Release lever
- (3) Operating cylinder

14) Push the release lever until the operating cylinder push rod retracts. Check whether the clutch fluid level in the reservoir tank increases or not.

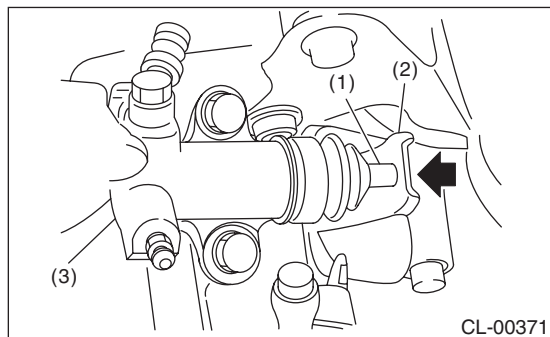

- (1) Push rod
- (2) Release lever
- (3) Operating cylinder

15) If the clutch fluid level increases, hydraulic clutch play is correct.

16) If the clutch fluid level does not increase or push rod does not retract, readjust the clutch pedal.

17) Check the fluid level using the scale on the outside of the reservoir tank. If the level is below "MIN", fill fluid up to "MAX" level.

Recommended clutch fluid:

FMVSS No. 116, fresh DOT3 or 4 brake fluid

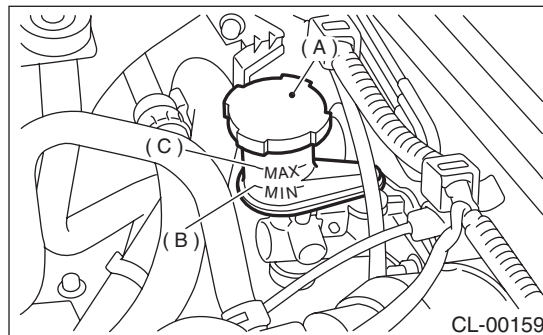

- (A) Reservoir tank
- (B) MIN. level
- (C) MAX. level