

### 6. Master Cylinder

#### A: REMOVAL

- 1) Thoroughly drain the brake fluid from the reservoir tank.
- 2) Remove the snap pin and clevis pin, and then separate the push rod of the master cylinder from clutch pedal.

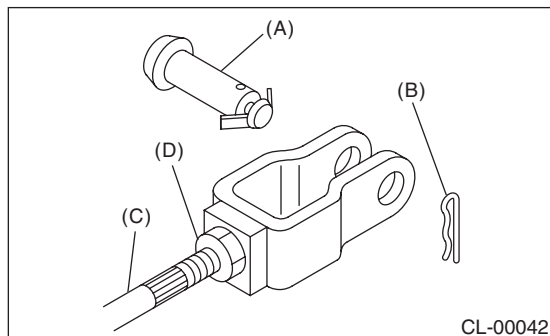

- (A) Clevis pin
- (B) Snap pin
- (C) Push rod
- (D) Lock nut

- 3) Remove the air intake chamber. <Ref. to IN(H4SO)-7, REMOVAL, Air Intake Chamber.>
- 4) Remove the clutch pipe from the master cylinder.
- 5) Remove the master cylinder and reservoir tank as a unit.

#### CAUTION:

**Be careful not to spill the brake fluid. Brake fluid spilled on the vehicle body will harm the paint surface; wipe off quickly if spilled.**

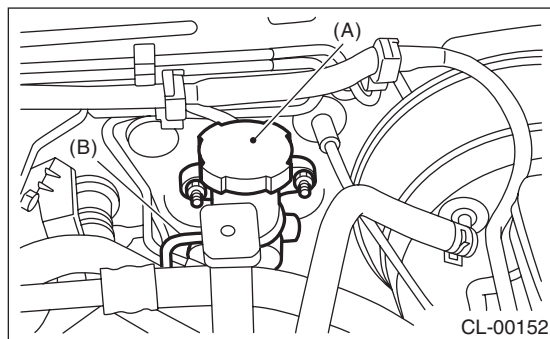

- (A) Master cylinder ASSY
- (B) Clutch pipe

#### B: INSTALLATION

- 1) Install the master cylinder to the vehicle body, and connect the clutch pipe to the master cylinder.

#### NOTE:

Check that the pipe is routed properly.

#### Tightening torque:

**T1: 15 N·m (1.5 kgf-m, 10.8 ft-lb)**

**T2: 18 N·m (1.8 kgf-m, 13.0 ft-lb)**

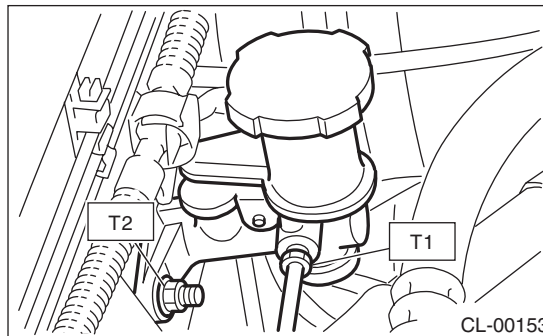

- 2) Connect the push rod of the master cylinder to the clutch pedal, and install the clevis pin and snap pin.

#### NOTE:

Apply grease to the clevis pin.

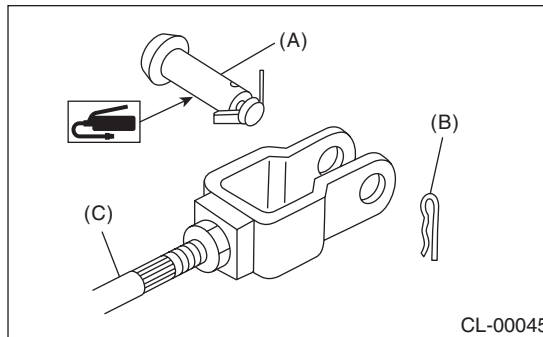

- (A) Clevis pin
- (B) Snap pin
- (C) Push rod

- 3) After bleeding air from the clutch system, ensure that the clutch operates properly.

<Ref. to CL-22, Clutch Fluid Air Bleeding.>

- 4) Install the air intake chamber. <Ref. to IN(H4SO)-7, INSTALLATION, Air Intake Chamber.>

## C: DISASSEMBLY

1) Remove the straight pin and reservoir tank.

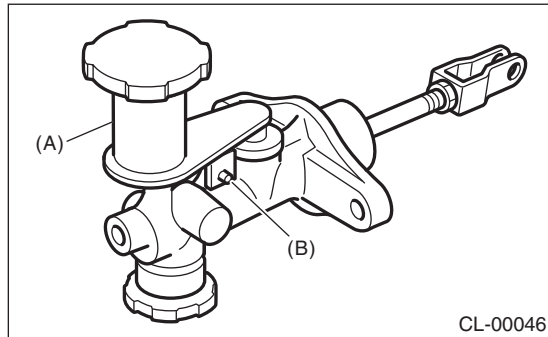

- (A) Reservoir tank
- (B) Straight pin

2) Remove the oil seal.

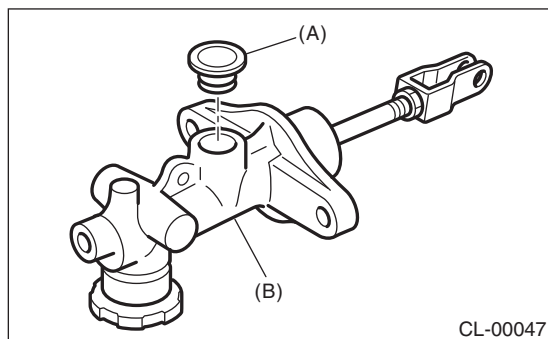

- (A) Oil seal
- (B) Master cylinder

3) Move the cylinder boot towards the rear.

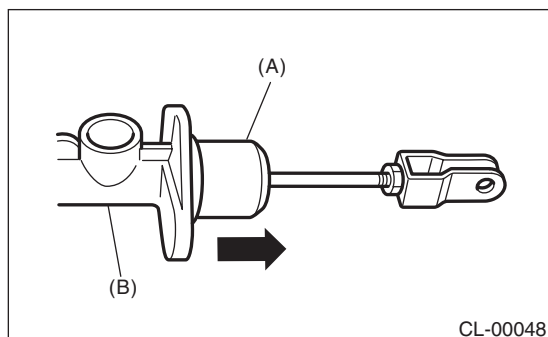

- (A) Cylinder boot
- (B) Master cylinder

4) Remove the snap ring.

### CAUTION:

**Be careful when removing the snap ring, to prevent the rod, washer, piston and return spring from flying out.**

5) Remove the clutch damper.

## D: ASSEMBLY

1) Install the clutch damper.

### Tightening torque:

**46.6 N·m (4.75 kgf·m, 34.4 ft·lb)**

2) Apply a coat of grease to the contact surfaces of the push rod and piston before installation.

### Grease:

**SILICONE GREASE G40M (Part No. 004404003)**

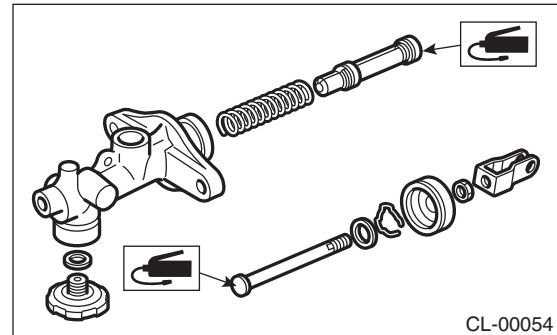

3) Assemble in the reverse order of disassembly.

### Tightening torque:

**10 N·m (1.0 kgf·m, 7 ft·lb)**

## E: INSPECTION

If any damage, deformation, wear, swelling, rust or other faults are found on the cylinder, piston, push rod, fluid reservoir, return spring, gasket, clutch damper, cylinder boot or hose, replace the faulty part.

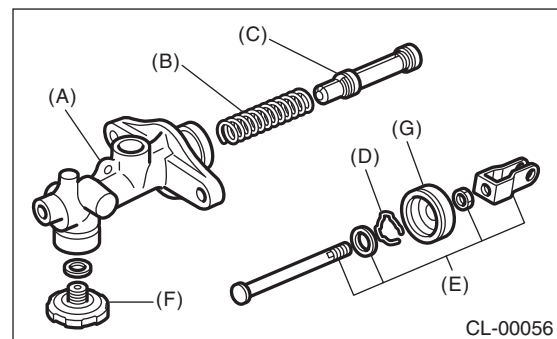

- (A) Master cylinder body
- (B) Return spring
- (C) Piston
- (D) Stop ring
- (E) Push rod ASSY
- (F) Clutch damper
- (G) Cylinder boot