

General Description

CONTROL SYSTEMS

1. General Description

A: SPECIFICATION

Item		Specification
Swing torque of rod against lever	N (kgf, lb)	3.7 (0.38, 0.84) or less

B: COMPONENT

1. AT SELECT LEVER

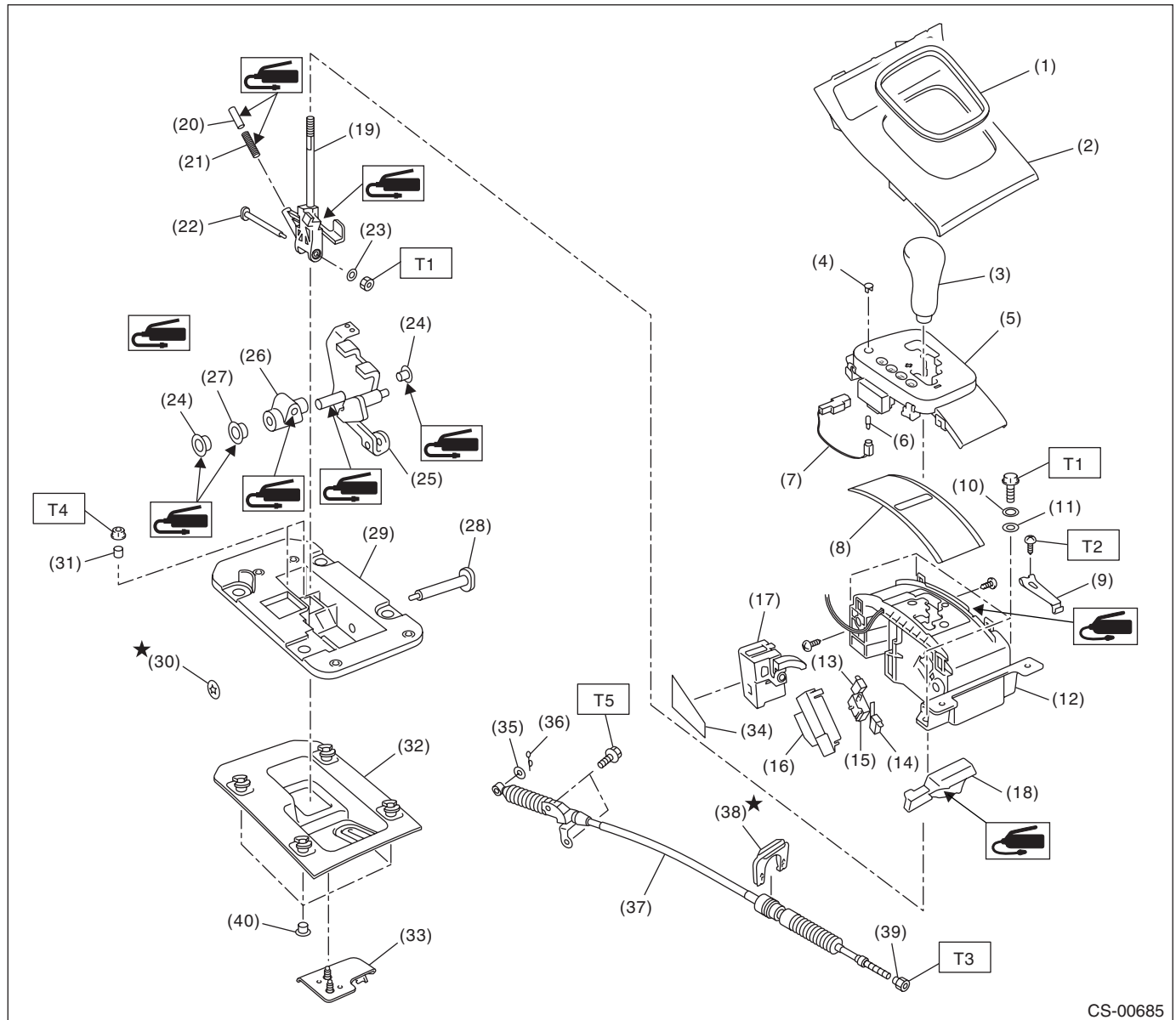

CS-00685

General Description

CONTROL SYSTEMS

(1) Ring indicator	(17) Shift lock solenoid ASSY	(33) Cable bracket
(2) Front cover	(18) Check plate	(34) Seat
(3) Grip	(19) Lever ASSY	(35) Washer
(4) Release cover	(20) Check ball	(36) Snap pin
(5) Indicator ASSY	(21) Return spring	(37) Select cable
(6) Indicator bulb	(22) Shaft	(38) Clamp
(7) Valve harness	(23) Washer	(39) Nut A
(8) Blind	(24) Bushing A	(40) Bushing
(9) Detent spring	(25) Arm ASSY	
(10) Spring washer	(26) Bushing plate	
(11) Washer	(27) Bushing B	
(12) Guide plate upper	(28) Shaft	
(13) Up switch	(29) Plate lower	
(14) Down switch	(30) Clamp	
(15) SPORT mode switch	(31) Collar	
(16) Switch cover	(32) Gasket	

Tightening torque: N-m (kgf-m, ft-lb)**T1: 5.1 (0.52, 3.8)****T2: 6.9 (0.70, 5.1)****T3: 7.5 (0.76, 5.5)****T4: 12.7 (1.3, 9.4)****T5: 18 (1.8, 13.3)**

General Description

CONTROL SYSTEMS

2. 5MT GEAR SHIFT LEVER

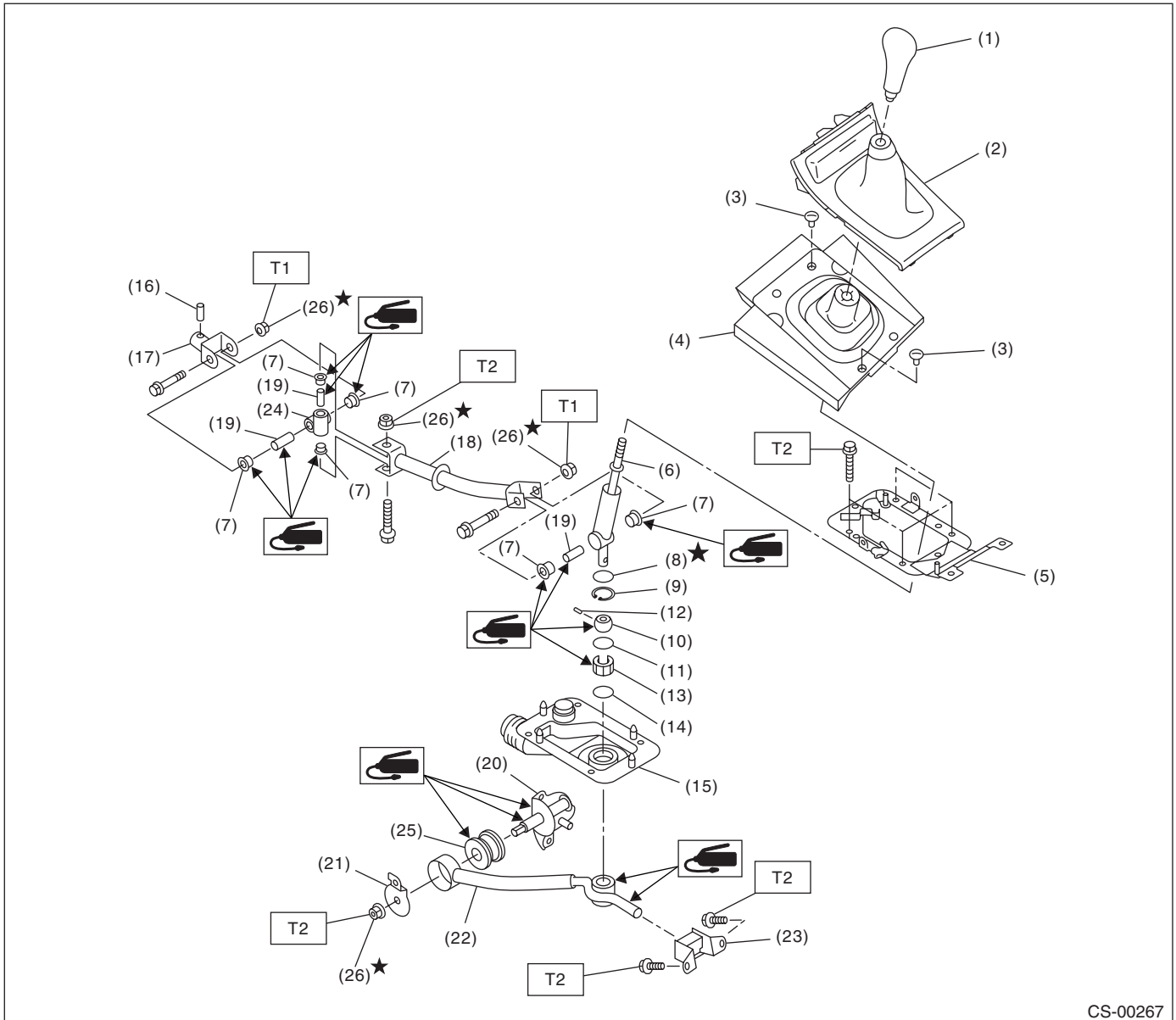

CS-00267

- | | | |
|---------------------------------|-----------------|-----------------------|
| (1) Gear shift knob | (11) O-ring | (21) Washer |
| (2) Front cover ASSY | (12) Spring pin | (22) Stay |
| (3) Clamp | (13) Bushing B | (23) Cushion rubber |
| (4) Boot and insulator assembly | (14) O-ring 4 | (24) Boss |
| (5) Plate ASSY | (15) Boot | (25) Bushing |
| (6) Lever | (16) Spring pin | (26) Self-locking nut |
| (7) Bushing | (17) Joint | |
| (8) Lock wire | (18) Rod | |
| (9) Snap ring | (19) Spacer | |
| (10) Bushing | (20) Bracket | |



Tightening torque: N-m (kgf-m, ft-lb)

T1: 12 (1.2, 8.9)

T2: 18 (1.8, 13.3)

C: PREPARATION TOOL

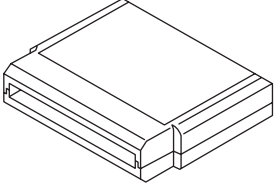
1. SPECIAL TOOL

ILLUSTRATION	TOOL NUMBER	DESCRIPTION	REMARKS
 <p style="text-align: center;">ST18482AA010</p>	18482AA010	CARTRIDGE	Troubleshooting for electrical system
 <p style="text-align: center;">ST22771AA030</p>	22771AA030	SUBARU SELECT MONITOR KIT	Troubleshooting for electrical system

D: CAUTION

- Wear appropriate work clothing, including a cap, protective goggles and protective shoes when performing any work.
- Remove contamination including dirt and corrosion before removal, installation or disassembly.
- Keep the disassembled parts in order and protect them from dust and dirt.
- Before removal, installation or disassembly, be sure to clarify the failure. Avoid unnecessary removal, installation, disassembly and replacement.
- Use SUBARU genuine fluid, grease etc. or equivalent. Do not mix fluid, grease, etc. of different grades or manufacturers.
- Be sure to tighten fasteners including bolts and nuts to the specified torque.
- Place shop jacks or rigid racks at the specified points.
- Apply grease onto sliding or revolving surfaces before installation.
- Before installing O-rings or snap rings, apply sufficient amount of fluid to avoid damage and deformation.
- Before securing a part in a vise, place cushioning material such as wood blocks, aluminum plate or cloth between the part and the vise.
- Before disconnecting electrical connectors, be sure to disconnect the negative terminal from battery.