

## 4. Select Cable

### A: REMOVAL

- 1) Set the vehicle on a lift.
- 2) Shift the select lever to "N" range.
- 3) Disconnect the ground cable from battery.
- 4) Lift up the vehicle.
- 5) Remove the front, center and rear exhaust pipes and the muffler. (SOHC and DOHC non-turbo model)

- SOHC model

<Ref. to EX(H4SO)-4, REMOVAL, Front Exhaust Pipe.> <Ref. to EX(H4SO)-7, REMOVAL, Center Exhaust Pipe.> <Ref. to EX(H4SO)-8, REMOVAL, Rear Exhaust Pipe.> <Ref. to EX(H4SO)-10, REMOVAL, Muffler.>

- DOHC 3.0 L model

<Ref. to EX(H6DO)-4, REMOVAL, Front Exhaust Pipe.> <Ref. to EX(H6DO)-7, REMOVAL, Rear Exhaust Pipe.> <Ref. to EX(H6DO)-9, REMOVAL, Muffler.>

- 6) Remove the center and rear exhaust pipes and the muffler. (DOHC turbo model)

<Ref. to EX(H4DOTC)-8, REMOVAL, Center Exhaust Pipe.> <Ref. to EX(H4DOTC)-12, REMOVAL, Rear Exhaust Pipe.> <Ref. to EX(H4DOTC)-13, REMOVAL, Muffler.>

- 7) Remove the heat shield cover.

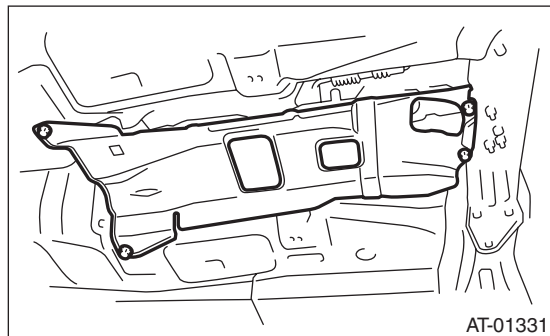

- 8) Remove the snap pin and washer from range select lever.

- 4AT

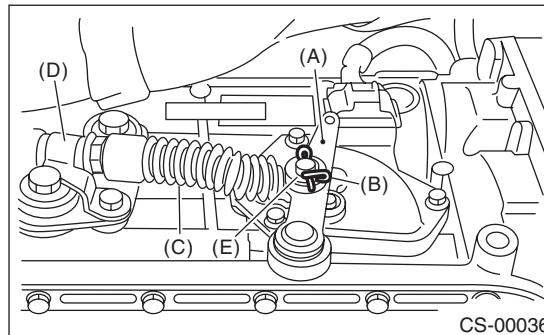

- (A) Range select lever
- (B) Snap pin
- (C) Select cable
- (D) Bracket
- (E) Washer

- 5AT

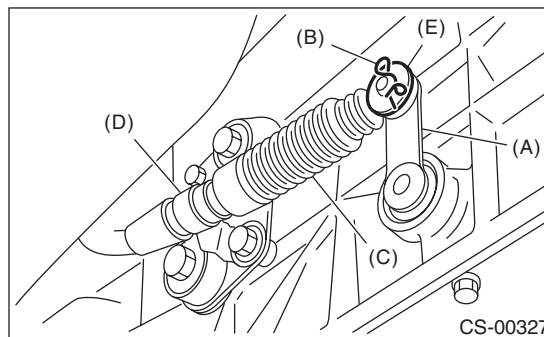

- (A) Range select lever
- (B) Snap pin
- (C) Select cable
- (D) Bracket
- (E) Washer

# Select Cable

## CONTROL SYSTEMS

9) Remove the plate assembly from the transmission case.

- 4AT

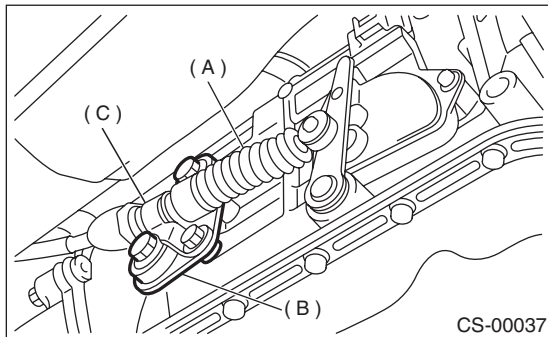

- (A) Select cable
- (B) Plate ASSY
- (C) Bracket

- 5AT

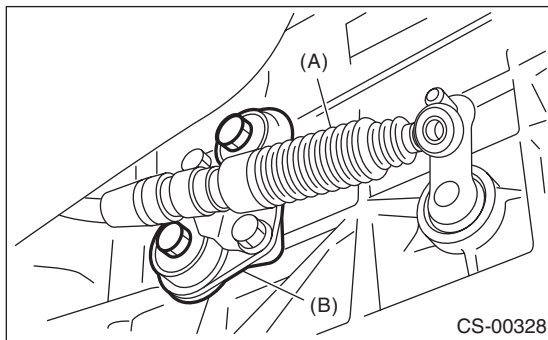

- (A) Select cable
- (B) Plate ASSY

10) Disconnect the cable from arm assembly.

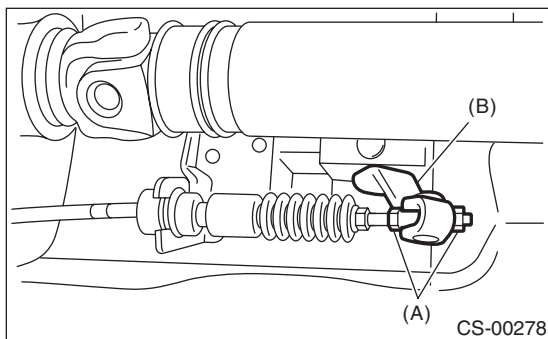

- (A) Adjusting nut
- (B) Arm ASSY

11) Raise the pawl of clamp to remove the cable from bracket.

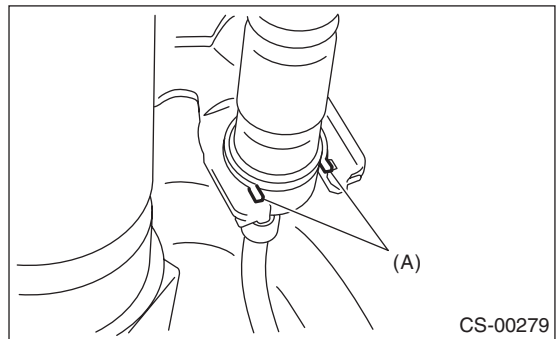

- (A) Claw

12) Remove the select cable from plate assembly.

## B: INSTALLATION

1) Install the select cable to plate assembly.

**Tightening torque:**

**18 N·m (1.8 kgf·m, 13.3 ft·lb)**

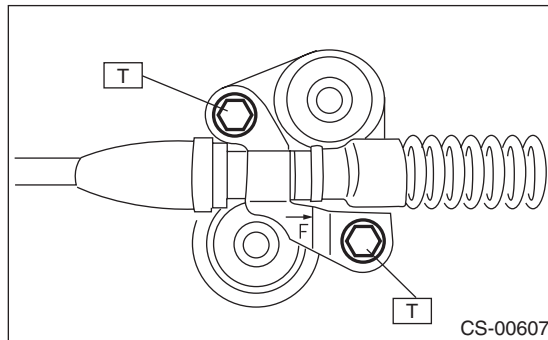

2) Install the select cable to range select lever.

3) Install the plate assembly to transmission.

**Tightening torque:**

**T: 24.5 N·m (2.5 kgf·m, 18.1 ft·lb)**

• 4AT

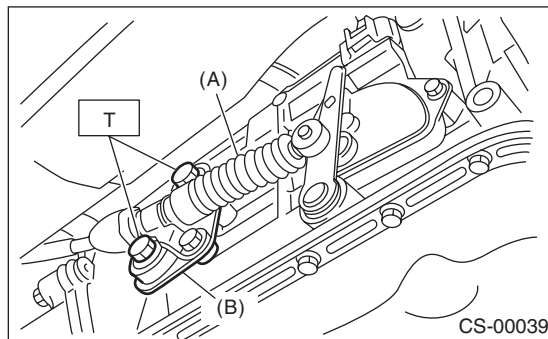

- (A) Select cable
- (B) Plate ASSY

• 5AT

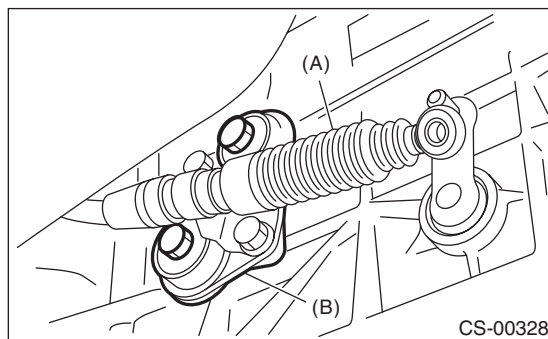

- (A) Select cable
- (B) Plate ASSY

4) Install the washer and snap pin to range select lever.

• 4AT

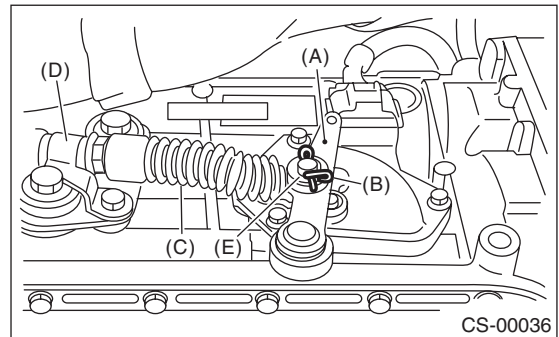

- (A) Range select lever
- (B) Snap pin
- (C) Select cable
- (D) Bracket
- (E) Washer

• 5AT

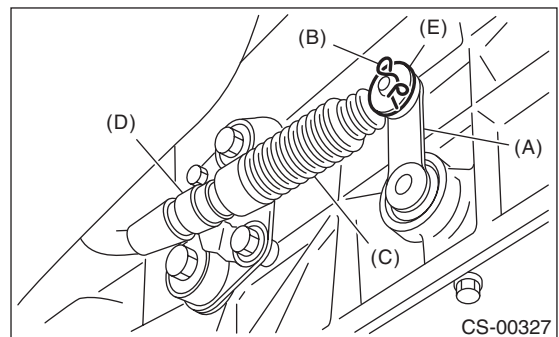

- (A) Range select lever
- (B) Snap pin
- (C) Select cable
- (D) Bracket
- (E) Washer

5) Install new clamp paying attention to the installing direction.

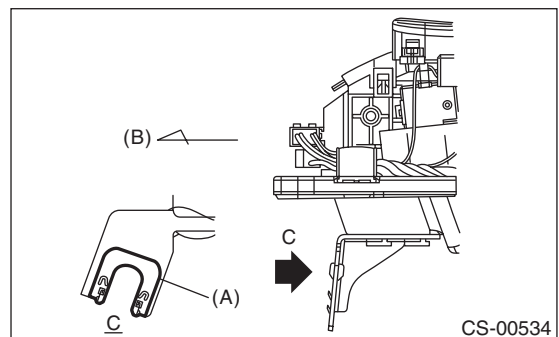

- (A) Clamp
- (B) Forward

## Select Cable

### CONTROL SYSTEMS

6) Insert the tip of inner cable into connector hole of select lever, and fix the cable to bracket.

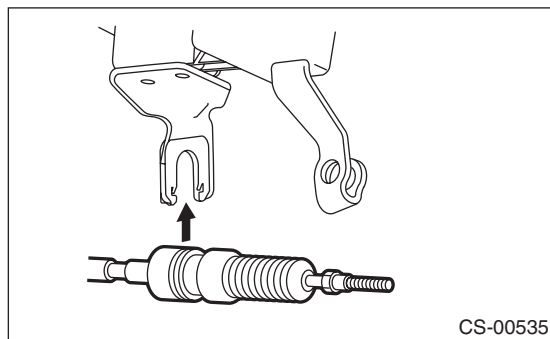

7) Shift the select lever to the "N" range, and then adjust the select cable position. <Ref. to CS-27, ADJUSTMENT, Select Cable.>

8) Install the heat shield cover.

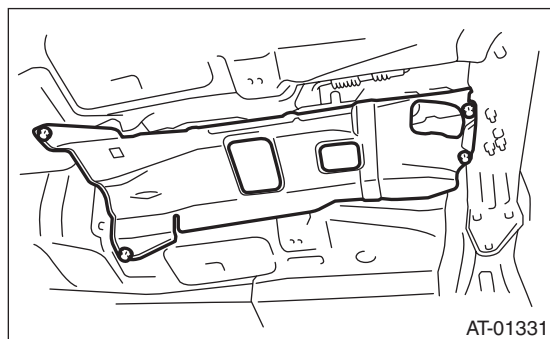

9) Install the front, center and rear exhaust pipes, and the muffler. (SOHC and DOHC non-turbo model)

- SOHC model

<Ref. to EX(H4SO)-5, INSTALLATION, Front Exhaust Pipe.> <Ref. to EX(H4SO)-7, INSTALLATION, Center Exhaust Pipe.> <Ref. to EX(H4SO)-8, INSTALLATION, Rear Exhaust Pipe.> <Ref. to EX(H4SO)-10, INSTALLATION, Muffler.>

- DOHC 3.0 L model

<Ref. to EX(H6DO)-5, INSTALLATION, Front Exhaust Pipe.> <Ref. to EX(H6DO)-7, INSTALLATION, Rear Exhaust Pipe.> <Ref. to EX(H6DO)-9, INSTALLATION, Muffler.>

10) Install the center, rear exhaust pipes and the muffler. (DOHC turbo model)

<Ref. to EX(H4DOTC)-9, INSTALLATION, Center Exhaust Pipe.> <Ref. to EX(H4DOTC)-12, INSTALLATION, Rear Exhaust Pipe.> <Ref. to EX(H4DOTC)-13, INSTALLATION, Muffler.>

### C: INSPECTION

Check the removed cable and replace or adjust if damaged, rusty or malfunctioning.

- 1) Check the cable for smooth operation.
- 2) Check the inner cable for damage and rust.
- 3) Check the outer cable for damage, bends and cracks.
- 4) Check the boot for damage, cracks and deterioration.
- 5) Move the select lever from "P" to "D" range. Check the existence of feel to contact the detents in each range. If the detents cannot be felt or the position pointer is improperly aligned, adjust the cable.
- 6) Check if the starter motor rotates when the select lever is set to "P" range.
- 7) Check the back-up light illumination when the select lever is in "R" range.
- 8) Check the parking lock operation when the select lever is in "P" range.

## D: ADJUSTMENT

- 1) Shift the select lever to "N" range.
- 2) Remove the rear exhaust pipe and muffler.
  - SOHC model  
<Ref. to EX(H4SO)-8, REMOVAL, Rear Exhaust Pipe.> <Ref. to EX(H4SO)-10, REMOVAL, Muffler.>
  - DOHC turbo model  
<Ref. to EX(H4DOTC)-12, REMOVAL, Rear Exhaust Pipe.> <Ref. to EX(H4DOTC)-13, REMOVAL, Muffler.>
  - DOHC 3.0 L model  
<Ref. to EX(H6DO)-7, REMOVAL, Rear Exhaust Pipe.> <Ref. to EX(H6DO)-9, REMOVAL, Muffler.>
- 3) Remove the heat shield cover.

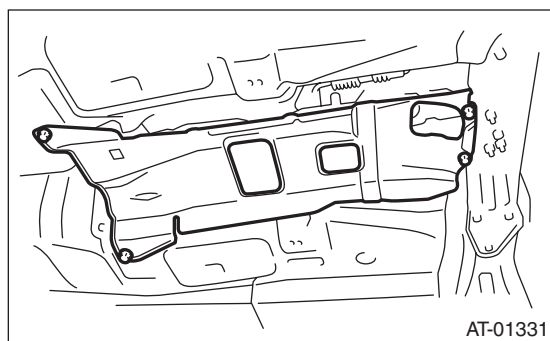

- 4) Loosen the adjusting nuts on both sides.

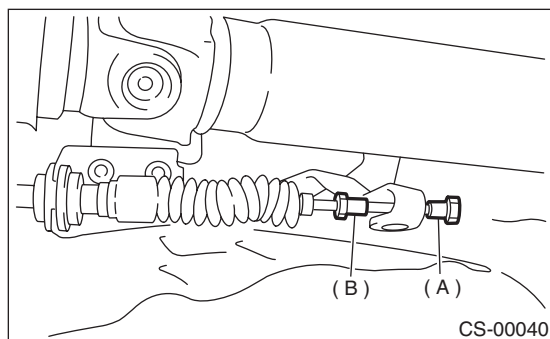

- (A) Adjusting nut A
- (B) Adjusting nut B

- 5) With the select lever pushed towards the rear of the vehicle, turn the adjustment nut B until it just contacts the connector. Then loosen the nut for 1/2 turn.

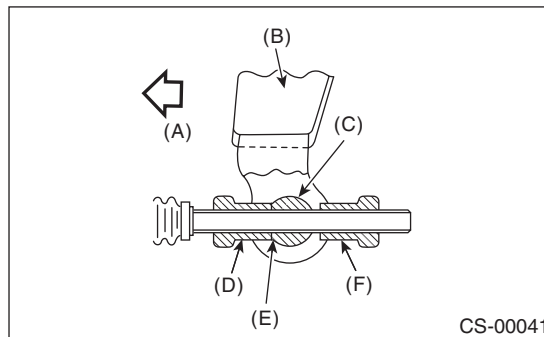

- (A) Forward side
- (B) Select lever
- (C) Connector
- (D) Adjusting nut B
- (E) Contact point
- (F) Adjusting nut A

- 6) Set a spanner wrench to adjusting nut B so that it does not rotate, and then tighten the adjusting nut A.

### **Tightening torque:**

**7.5 N·m (0.76 kgf·m, 5.5 ft·lb)**

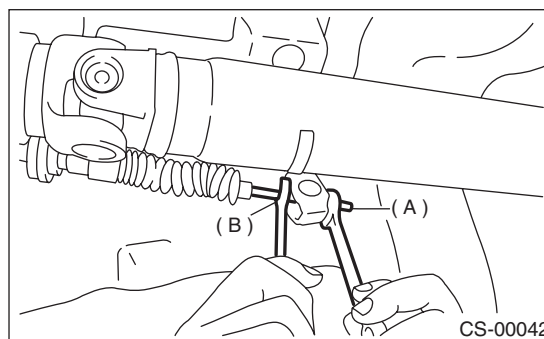

- (A) Adjusting nut A
- (B) Adjusting nut B

- 7) After the completion of adjustment, confirm that the select lever operates normally at all ranges.
- 8) Install in the reverse order of removal.