

Center Differential

MANUAL TRANSMISSION AND DIFFERENTIAL

12.Center Differential

A: REMOVAL

- 1) Remove the manual transmission assembly from the vehicle. <Ref. to 5MT-24, REMOVAL, Manual Transmission Assembly.>
- 2) Remove the transfer case together with the extension case assembly. <Ref. to 5MT-36, REMOVAL, Transfer Case and Extension Case Assembly.>
- 3) Remove the extension case assembly. <Ref. to 5MT-36, REMOVAL, Transfer Case and Extension Case Assembly.>
- 4) Remove the transfer driven gear. <Ref. to 5MT-42, REMOVAL, Transfer Driven Gear.>
- 5) Remove the center differential.

B: INSTALLATION

- 1) Install the center differential into transfer case.
- 2) Install the transfer driven gear. <Ref. to 5MT-42, INSTALLATION, Transfer Driven Gear.>
- 3) Install the extension case assembly. <Ref. to 5MT-36, INSTALLATION, Transfer Case and Extension Case Assembly.>
- 4) Install the transfer case together with the extension case assembly. <Ref. to 5MT-36, INSTALLATION, Transfer Case and Extension Case Assembly.>
- 5) Install the back-up light switch and the neutral position switch. <Ref. to 5MT-33, INSTALLATION, Switches and Harness.>
- 6) Install the manual transmission assembly to the vehicle. <Ref. to 5MT-26, INSTALLATION, Manual Transmission Assembly.>

C: DISASSEMBLY

NOTE:

Center differential is a non-disassembled part which should not be disassembled.

Remove the ball bearing using ST.

NOTE:

Do not reuse the ball bearing.

ST 498077300 CENTER DIFFERENTIAL BEARING REMOVER

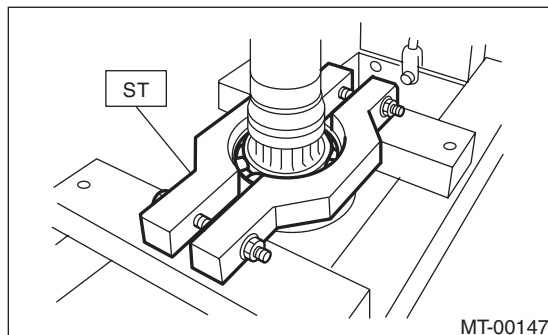

D: ASSEMBLY

Install the ball bearing into the center differential assembly.

NOTE:

Do not apply pressure in excess of 10 kN (1 ton, 1.1 US ton, 1.0 Imp ton).

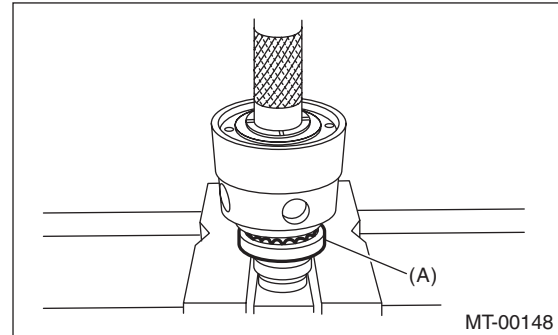

(A) Ball bearing

E: INSPECTION

1) Bearing

Replace the bearings in the following cases.

- In case of broken or rusty bearings
- In case of worn or damaged bearings
- When the bearings fail to turn smoothly or emit noise in rotation after gear oil lubrication.
- When bearing has other defects.

2) Center differential

Replace the center differential case assembly if worn or damaged.