

Transmission Case

MANUAL TRANSMISSION AND DIFFERENTIAL

14. Transmission Case

A: REMOVAL

- 1) Remove the manual transmission assembly from the vehicle. <Ref. to 5MT-24, REMOVAL, Manual Transmission Assembly.>
- 2) Remove the clutch release lever. <Ref. to CL-14, REMOVAL, Release Bearing and Lever.>
- 3) Remove the transfer case together with the extension case assembly. <Ref. to 5MT-36, REMOVAL, Transfer Case and Extension Case Assembly.>
- 4) Remove the bearing mounting bolt.

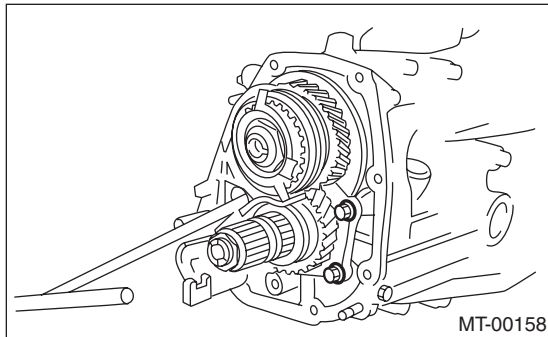

- 5) Remove the main shaft rear plate.

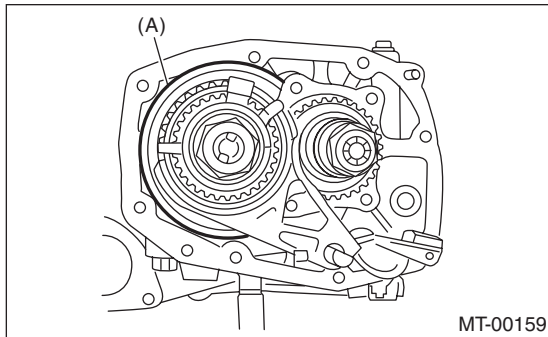

(A) Main shaft rear plate

- 6) Separate the transmission case into the right and left cases by loosening the coupling bolts and nuts.

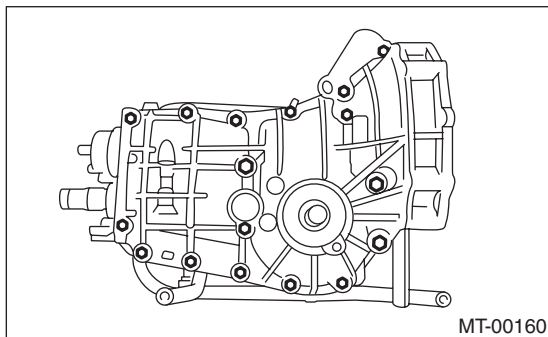

- 7) Remove the drive pinion shaft assembly from the left side of the transmission case.

NOTE:

Use a hammer handle, etc. to remove if too tight.

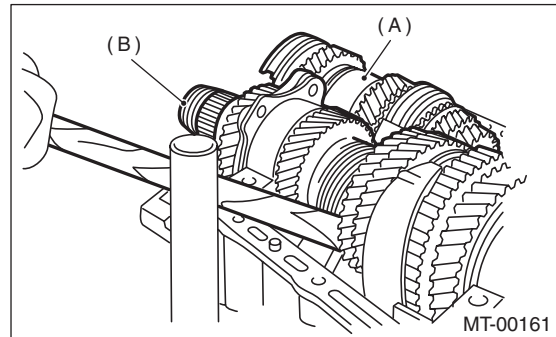

(A) Main Shaft Assembly for Single-Range

(B) Drive pinion shaft ASSY

- 8) Remove the main shaft assembly for single-range.
- 9) Remove the front differential assembly.

NOTE:

- Do not confuse the right and left roller bearing outer races.
- Be careful not to damage the oil seal of retainer.

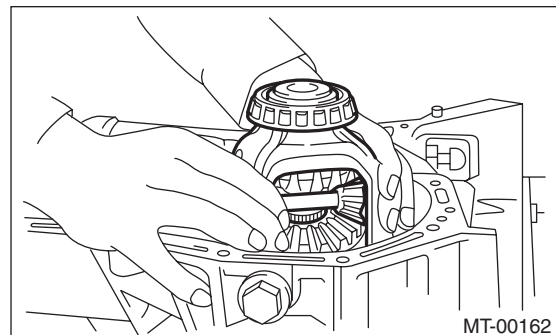

Transmission Case

MANUAL TRANSMISSION AND DIFFERENTIAL

B: INSTALLATION

- 1) Wipe off grease, oil and dust on the mating surfaces of transmission cases with white gasoline.
- 2) Install the front differential assembly.
- 3) Install the main shaft assembly for single-range. Install the transmission case knock pin into the knock pin hole of needle bearing.
- 4) Install the drive pinion shaft assembly. Install the transmission case knock pin into the roller bearing knock pin hole.
- 5) Apply liquid gasket, then join the right side and left side of the case together.

Liquid gasket:

THREE BOND 1215 (Part No. 004403007) or equivalent

- 6) With brackets and clips as shown in the figure, tighten the seventeen bolts.

NOTE:

Insert the bolts from the bottom and tighten the nuts at the top.

Tightening torque:

8 mm bolt

25 N·m (2.5 kgf·m, 18.1 ft·lb)

★ **10 mm bolt**

39 N·m (4.0 kgf·m, 28.9 ft·lb)

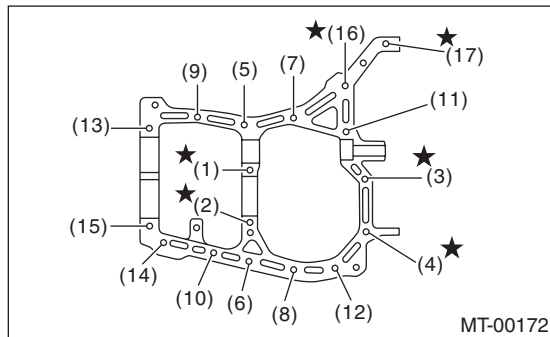

- 7) Tighten the ball bearing mounting bolts.

Tightening torque:

30 N·m (3.1 kgf·m, 22.1 ft·lb)

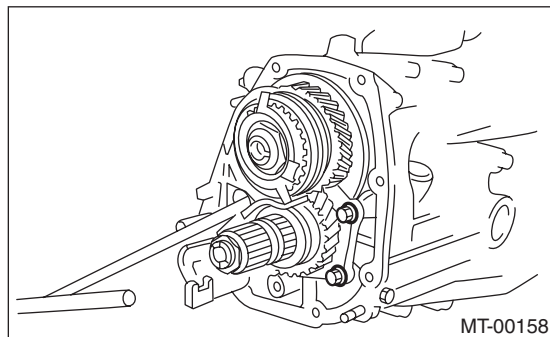

- 8) Backlash adjustment of the hypoid gear and pre-load adjustment of the roller bearing.

NOTE:

Install the ST on drive pinion assembly.

ST 498427100 STOPPER

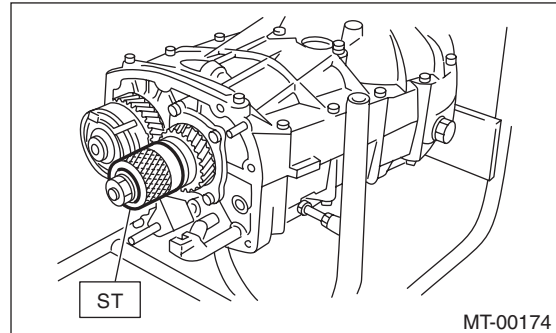

- 9) Place the transmission with the left side of case facing downward, and put ST1 on bearing cup.

- 10) Screw the retainer assembly from the bottom into left case using ST2. Fit the ST3 on transmission main shaft. Shift the gear into 4th or 5th, and turn the shaft several times. Screw in the retainer while rotating the ST3 until a slight resistance is felt on ST2.

This is the contact point of the hypoid gear and the drive pinion shaft. Repeat the above sequence several times to ensure the contact point.

ST1 399780104 WEIGHT

ST2 499787000 WRENCH ASSY

ST3 499927100 HANDLE

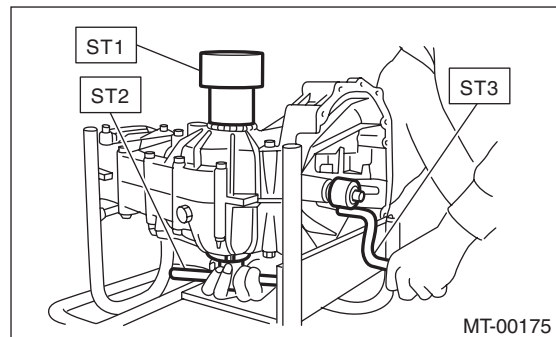

Transmission Case

MANUAL TRANSMISSION AND DIFFERENTIAL

11) Remove the weight, and screw in the retainer without the O-ring on the upper side, and stop at the point where a slight resistance is felt.

NOTE:

In this condition, the backlash between hypoid gear and drive pinion shaft is zero.

ST 499787000 WRENCH ASSY

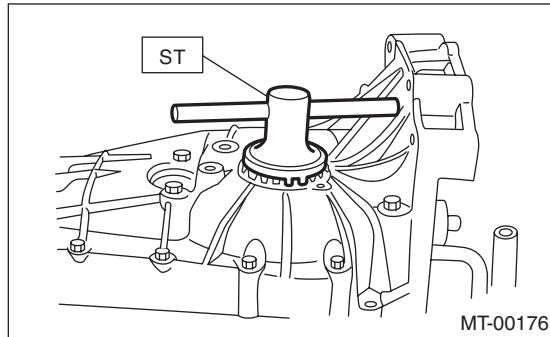

12) Loosen the retainer on the lower side by 3 notches and turn the retainer on the upper side by the same amount in order to apply backlash.

13) Rotate the retainer of the upper side additionally by 1 notch in order to apply preload on taper roller bearing.

14) Install temporarily both the upper and lower lock plates, and put marks both the holder and lock plate for later readjustment.

NOTE:

Install the lock plate upside down if it is hard to install.

15) Turn the transmission main shaft several times while tapping around the retainer lightly with plastic hammer.

16) Inspect and adjust backlash and tooth contact of the hypoid gear. <Ref. to 5MT-69, INSPECTION, Front Differential Assembly.>

17) After checking the tooth contact of the hypoid gears, remove the lock plate. Then loosen the retainer until the O-ring groove appears. Fit the O-ring into the groove and tighten the retainer to the original position.

Install the lock plate.

NOTE:

- Record how many times the retainer is turned while loosening.
- Perform this for both upper and lower retainers.

Tightening torque:

T: 25 N·m (2.5 kgf-m, 18.4 ft-lb)

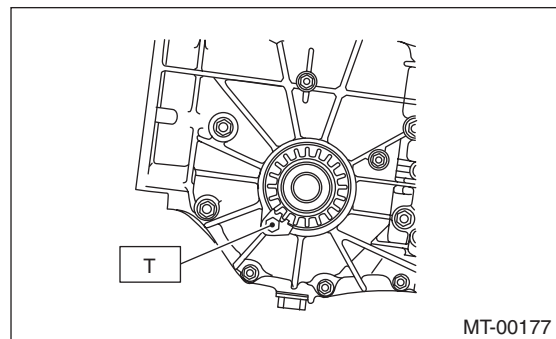

18) Selection of the main shaft rear plate <Ref. to 5MT-56, ADJUSTMENT, Main Shaft Assembly for Single-range.>

19) Install the clutch release lever and bearing. <Ref. to CL-14, INSTALLATION, Release Bearing and Lever.>

20) Install the transfer case together with the extension case assembly. <Ref. to 5MT-36, INSTALLATION, Transfer Case and Extension Case Assembly.>

21) Install the manual transmission assembly to the vehicle. <Ref. to 5MT-26, INSTALLATION, Manual Transmission Assembly.>

C: INSPECTION

Check the transmission case for cracks, damage, or oil leaks.