

18. Reverse Idler Gear

A: REMOVAL

- 1) Remove the manual transmission assembly from the vehicle. <Ref. to 5MT-24, REMOVAL, Manual Transmission Assembly.>
- 2) Remove the back-up light switch and the neutral position switch. <Ref. to 5MT-33, REMOVAL, Switches and Harness.>
- 3) Remove the transfer case together with the extension case assembly. <Ref. to 5MT-36, REMOVAL, Transfer Case and Extension Case Assembly.>
- 4) Remove the transmission case. <Ref. to 5MT-57, REMOVAL, Drive Pinion Shaft Assembly.>
- 5) Remove the drive pinion shaft assembly. <Ref. to 5MT-57, REMOVAL, Drive Pinion Shaft Assembly.>
- 6) Remove the main shaft assembly. <Ref. to 5MT-51, REMOVAL, Main Shaft Assembly for Single-range.>
- 7) Remove the differential assembly. <Ref. to 5MT-66, REMOVAL, Front Differential Assembly.>
- 8) Remove the shifter forks and rods. <Ref. to 5MT-75, REMOVAL, Shifter Fork and Rod.>
- 9) Pull out the straight pin, and remove the idler gear shaft, reverse idler gear and washer.

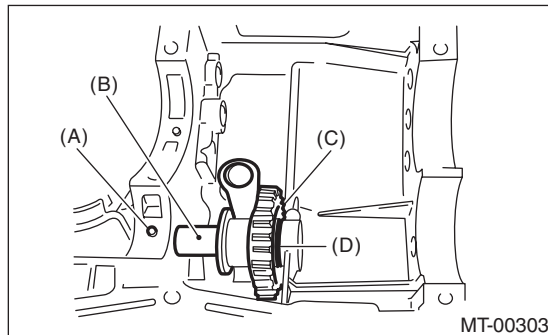

- (A) Straight pin
- (B) Reverse idler gear shaft
- (C) Reverse idler gear
- (D) Washer

- 10) Remove the reverse shifter lever.

B: INSTALLATION

- 1) Install the reverse shifter lever, reverse idler gear and reverse idler gear shaft, and secure them with the straight pin.

NOTE:

Be sure to install the reverse idler shaft from rear side.

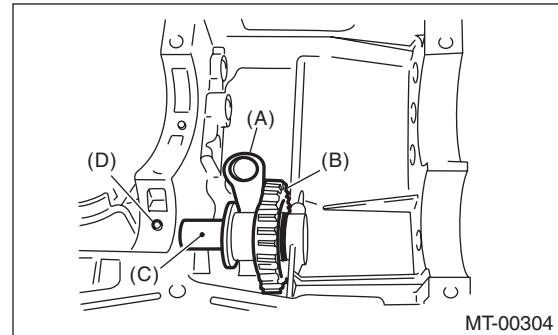

- (A) Reverse shifter lever
- (B) Reverse idler gear
- (C) Reverse idler gear shaft
- (D) Straight pin

- 2) Check and adjust clearance between the reverse idler gear and the timing case wall surface. <Ref. to 5MT-73, INSTALLATION, Reverse Idler Gear.> <Ref. to 5MT-74, ADJUSTMENT, Reverse Idler Gear.>
- 3) Install the shifter forks and rods. <Ref. to 5MT-75, INSTALLATION, Shifter Fork and Rod.>
- 4) Install the differential assembly. <Ref. to 5MT-66, INSTALLATION, Front Differential Assembly.>
- 5) Install the main shaft assembly. <Ref. to 5MT-51, INSTALLATION, Main Shaft Assembly for Single-range.>
- 6) Install the drive pinion shaft assembly. <Ref. to 5MT-57, INSTALLATION, Drive Pinion Shaft Assembly.>
- 7) Install the transmission case. <Ref. to 5MT-49, INSTALLATION, Transmission Case.>
- 8) Install the transfer case together with the extension case assembly. <Ref. to 5MT-36, INSTALLATION, Transfer Case and Extension Case Assembly.>
- 9) Install the back-up light switch and neutral position switch. <Ref. to 5MT-33, INSTALLATION, Switches and Harness.>
- 10) Install the manual transmission assembly to the vehicle. <Ref. to 5MT-26, INSTALLATION, Manual Transmission Assembly.>

Reverse Idler Gear

MANUAL TRANSMISSION AND DIFFERENTIAL

C: INSPECTION

1) Move the reverse shifter rod toward the reverse side. Check the clearance between the reverse idler gear and the timing case wall surface. If out of specification, select an appropriate reverse shifter lever and adjust.

Clearance A:

6.0 — 7.5 mm (0.236 — 0.295 in)

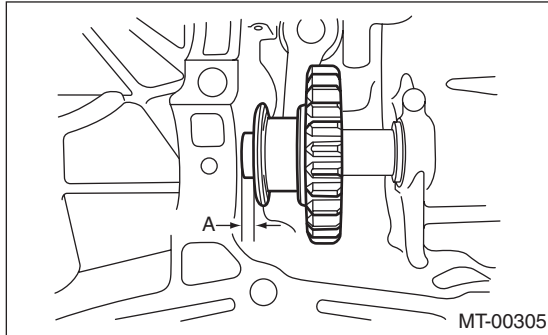

2) After installing a suitable reverse shifter lever, shift into neutral. Check the clearance between the reverse idler gear and the timing case wall surface. If out of specification, select the appropriate washer and adjust.

Clearance:

0 — 0.5 mm (0 — 0.020 in)

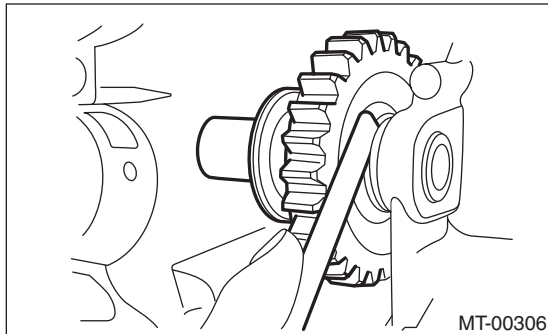

3) Check the reverse idler gear and shaft for damage. Replace if it is damaged.

D: ADJUSTMENT

1) Select the appropriate reverse shifter lever from the table below, and adjust until the clearance between the reverse idler gear and transmission case wall is within specification.

Clearance A:

6.0 — 7.5 mm (0.236 — 0.295 in)

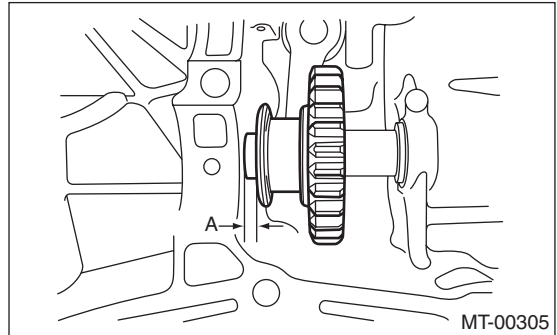

Reverse shifter lever		
Part number	Mark	Remarks
32820AA070	7	Far from case wall
32820AA080	8	Standard
32820AA090	9	Closer to case wall

2) Select the appropriate washer from the table below, and adjust until the clearance between the reverse idler gear and transmission case wall is within specification.

Clearance:

0 — 0.5 mm (0 — 0.020 in)

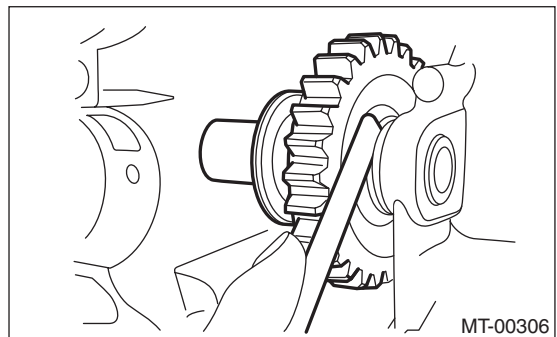

Washer	
Part number	Thickness mm (in)
803020151	0.4 (0.016)
803020152	1.1 (0.043)
803020153	1.5 (0.059)
803020154	1.9 (0.075)
803020155	2.3 (0.091)