

Shifter Fork and Rod

MANUAL TRANSMISSION AND DIFFERENTIAL

19. Shifter Fork and Rod

A: REMOVAL

1) Remove the manual transmission assembly from the vehicle. <Ref. to 5MT-24, REMOVAL, Manual Transmission Assembly.>

2) Remove the back-up light switch and the neutral position switch. <Ref. to 5MT-33, REMOVAL, Switches and Harness.>

3) Remove the transfer case together with the extension case assembly. <Ref. to 5MT-36, REMOVAL, Transfer Case and Extension Case Assembly.>

4) Remove the transmission case. <Ref. to 5MT-48, REMOVAL, Transmission Case.>

5) Remove the drive pinion shaft assembly. <Ref. to 5MT-57, REMOVAL, Drive Pinion Shaft Assembly.>

6) Remove the main shaft assembly. <Ref. to 5MT-51, REMOVAL, Main Shaft Assembly for Single-range.>

7) Remove the differential assembly. <Ref. to 5MT-66, REMOVAL, Front Differential Assembly.>

8) Drive out the straight pin by tapping with the ST, and pull out the 5th shifter fork.

ST 398791700 STRAIGHT PIN REMOVER

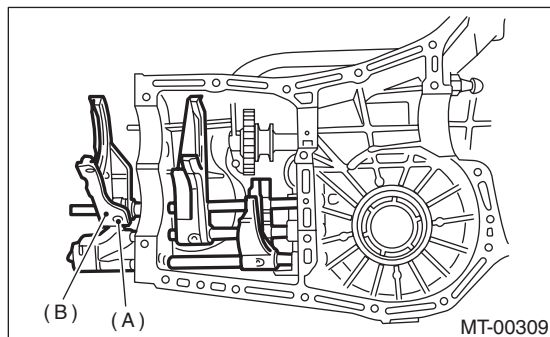

- (A) Straight pin
- (B) 5th shifter fork

9) Remove the plugs, springs and check balls.

10) Drive out the straight pin tapping by the ST, and pull out the 3-4 fork rod and shifter fork.

NOTE:

When removing the rod, keep other rods in neutral. Also, when pulling out the straight pin, remove it toward the inside of case so that it does not hit against the case.

ST 398791700 STRAIGHT PIN REMOVER

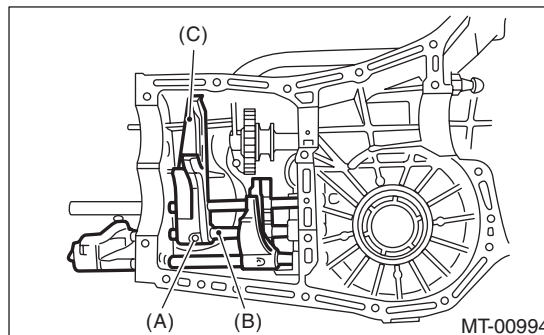

- (A) Straight pin
- (B) 3-4 fork rod
- (C) Shifter fork

11) Drive out the straight pin by tapping with the ST, and pull out the 1-2 fork rod and shifter fork.

ST 398791700 STRAIGHT PIN REMOVER

12) Remove the outer snap ring, and pull out the reverse shifter rod arm and reverse fork rod. Then take out the ball, spring and interlock plunger from the rod.

And then remove the rod.

NOTE:

When pulling out the reverse shifter rod arm, be careful not to let the ball pop out of arm.

13) Remove the reverse shifter lever.

B: INSTALLATION

1) Install the reverse arm fork spring, ball and interlock plunger to the reverse fork rod arm. Insert the reverse fork rod into the hole of the reverse fork rod arm, and hold it with the outer snap ring using ST.

NOTE:

Apply grease to plunger to prevent it from falling.

ST 399411700 ACCENT BALL INSTALLER

2) Position the ball, spring and new gasket in the reverse shifter rod hole on the left side of transmission case, and tighten the checking ball plug.

3) Install the 1st-2nd fork rod into 1st-2nd shifter fork through the hole on the rear of transmission case.

Shifter Fork and Rod

MANUAL TRANSMISSION AND DIFFERENTIAL

4) Align the holes in the rod and the fork, and drive the new straight pin into these holes.

NOTE:

- Set other rods to neutral.
- Make sure the interlock plunger is on the 3rd-4th fork rod side.

ST 398791700 STRAIGHT PIN REMOVER

5) Install the interlock plunger onto the 3-4 fork rod.

NOTE:

Apply grease to plunger to prevent it from falling.

6) Install the 3rd-4th fork rod into the 3rd-4th shifter fork through the hole on the rear of transmission case.

7) Align the holes in the rod and the fork, and drive the new straight pin into these holes.

NOTE:

- Set the reverse fork rod to neutral.
- Make sure the interlock plunger (before installation) is on the reverse fork rod side.

ST 398791700 STRAIGHT PIN REMOVER

8) Install the 5th shifter fork onto the rear of reverse fork rod. Align the holes in the two parts and drive new straight pin into the specified place.

ST 398791700 STRAIGHT PIN REMOVER

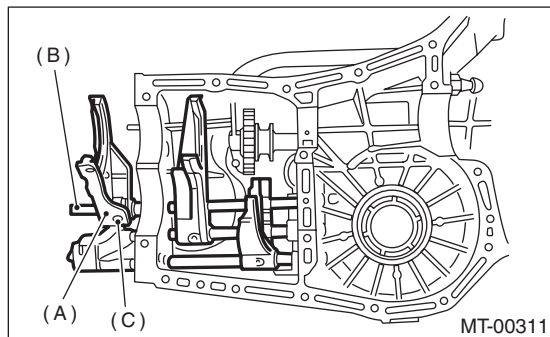

- (A) 5th shifter fork
- (B) Reverse fork rod
- (C) Straight pin

9) Position the balls, checking ball springs and new gaskets into 3-4 and 1-2 rod holes, and install plugs.

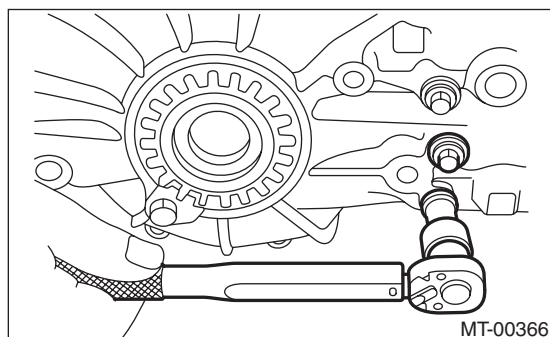

10) Install the differential assembly. <Ref. to 5MT-66, INSTALLATION, Front Differential Assembly.>

11) Install the main shaft assembly. <Ref. to 5MT-51, INSTALLATION, Main Shaft Assembly for Single-range.>

12) Install the drive pinion shaft assembly. <Ref. to 5MT-57, INSTALLATION, Drive Pinion Shaft Assembly.>

13) Install the transmission case. <Ref. to 5MT-49, INSTALLATION, Transmission Case.>

14) Install the transfer case together with the extension case assembly. <Ref. to 5MT-36, INSTALLATION, Transfer Case and Extension Case Assembly.>

15) Install the back-up light switch and neutral position switch. <Ref. to 5MT-33, INSTALLATION, Switches and Harness.>

16) Install the manual transmission assembly to the vehicle. <Ref. to 5MT-26, INSTALLATION, Manual Transmission Assembly.>

C: INSPECTION

1) Check the fork and rod for damage. Replace if it is damaged.

2) Gearshift mechanism

Repair or replace the gearshift mechanism if excessively worn, bent or defective in any way.

3) Inspect the clearance between 1st, 2nd driven gear and reverse driven gear. If any clearance is not within specifications, replace the shifter fork as required.

Clearance (a) and (b):
9.5 mm (0.374 in)

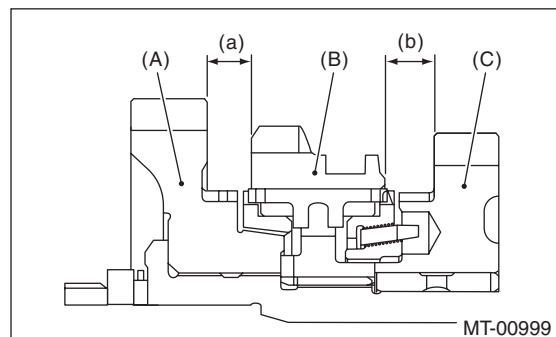

- (A) 1st driven gear
- (B) Reverse driven gear
- (C) 2nd driven gear

| 1st-2nd shifter fork | | |
|----------------------|------|--|
| Part number | Mark | Remarks |
| 32804AA060 | 1 | Approaches 1st gear by 0.2 mm (0.008 in). |
| 32804AA070 | — | Standard |
| 32804AA080 | 3 | Moves away from 2nd gear by 0.2 mm (0.008 in). |

Shifter Fork and Rod

4) Inspect the clearance between the 3rd, 4th drive gear and the coupling sleeve. If any clearance is not within specifications, replace the shifter fork as required.

Clearance (a) and (b):
7.3 mm (0.287 in)

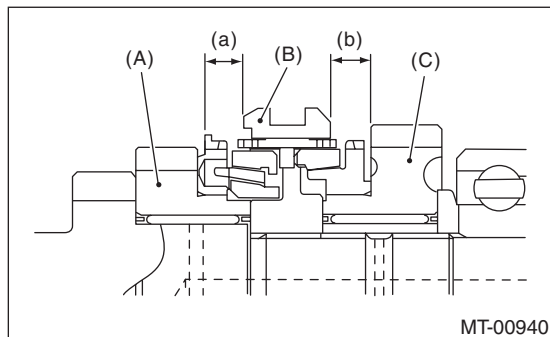

- (A) 3rd drive gear
- (B) Coupling sleeve
- (C) 4th drive gear

| 3rd-4th shifter fork | | |
|----------------------|------|--|
| Part number | Mark | Remarks |
| 32810AA061 | 1 | Approaches 4th gear by 0.2 mm (0.008 in). |
| 32810AA071 | — | Standard |
| 32810AA101 | 3 | Moves away from 3rd gear by 0.2 mm (0.008 in). |

5) Inspect the clearance between 5th drive gear and coupling sleeve. If any clearance is not within specifications, replace the shifter fork as required.

Clearance (a):
9.3 mm (0.366 in)

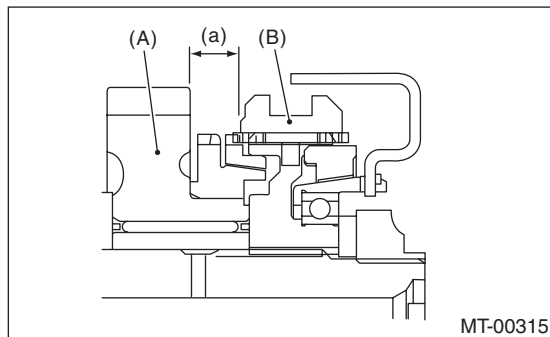

- (A) 5th drive gear
- (B) Coupling sleeve

| 5th shifter fork (Non-turbo model) | | |
|------------------------------------|---------|--|
| Part number | Mark | Remarks |
| 32812AA201 | 7 | Approaches 5th gear by 0.2 mm (0.008 in). |
| 32812AA211 | No mark | Standard |
| 32812AA221 | 9 | Moves away from 5th gear by 0.2 mm (0.008 in). |

| 5th shifter fork (Turbo model) | | |
|--------------------------------|---------|--|
| Part number | Mark | Remarks |
| 32812AA231 | 7 | Approaches 5th gear by 0.2 mm (0.008 in). |
| 32812AA241 | No mark | Standard |
| 32812AA251 | 9 | Moves away from 5th gear by 0.2 mm (0.008 in). |

6) Inspect the rod end clearances (A) and (B). If any clearance is not within specifications, replace the rod or fork as required.

Clearance (A):
3rd-4th — 5th
0.5 — 1.3 mm (0.020 — 0.051 in)

Clearance (B):
1st-2nd — 3rd-4th
0.4 — 1.4 mm (0.016 — 0.055 in)

