

# Front Disc Rotor

BRAKE

## 3. Front Disc Rotor

### A: REMOVAL

#### 1. 16-INCH TYPE

- 1) Lift-up the vehicle, and remove the front wheels.
- 2) Remove the caliper body and the support from housing, and suspend it from the strut using a wire.

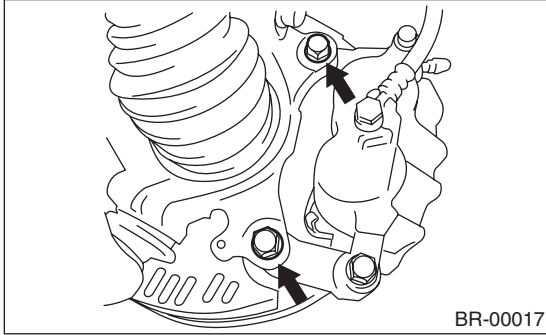

- 3) Remove the disc rotor.

#### NOTE:

If it is difficult to remove the disc rotor from the hub, drive an 8 mm bolt into the threaded section (B) of the rotor, then remove the rotor.

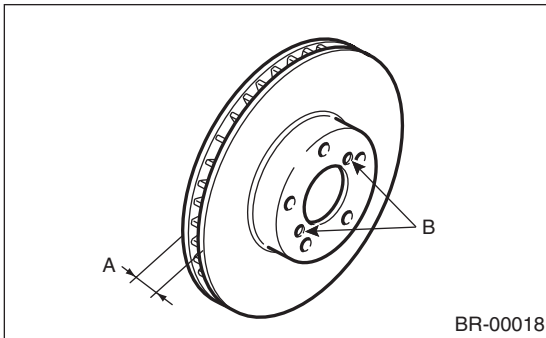

- 4) Remove mud and foreign matter from the caliper body assembly and the support.

#### 2. 17-INCH TYPE

Refer to 16-inch type. <Ref. to BR-16, 16-INCH TYPE, REMOVAL, Front Disc Rotor.>

### B: INSTALLATION

- 1) Install the disc rotor.
- 2) Install the caliper body and the support to housing.

#### Tightening torque:

**80 N·m (8.2 kgf·m, 59 ft·lb)**

- 3) Install the front wheels.

### C: INSPECTION

- 1) Check the front wheel bearing play and axle hub runout before the inspection of disc rotor runout limit. <Ref. to DS-16, INSPECTION, Front Axle.>
- 2) Secure the disc rotor by tightening the five wheel nuts.
- 3) Set a dial gauge 10 mm (0.39 in) inward from the disc rotor outer circumference. Rotate the disc rotor to check runout. If the runout of disc rotor exceeds the service limit, resurface the disc rotor. After resurfacing, check disc rotor thickness as in step 4).

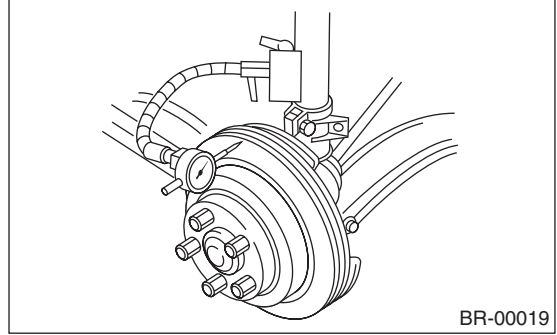

#### Disc rotor runout limit:

**0.05 mm (0.0020 in)**

- 4) Set a micrometer 10 mm (0.39 in) inward from the disc rotor outer perimeter, and then measure the disc rotor thickness. If the thickness of disc rotor exceeds the service limit, replace with a new disc rotor.

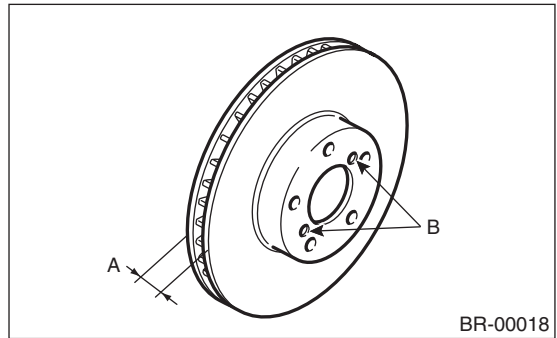

		Standard	Limit	Disc rotor outer diameter
Disc rotor thickness A mm (in)	16"	24 (0.94)	22 (0.87)	294 (11.57)
	17"	30 (1.18)	28 (1.10)	316 (12.44)