

5. Rear Brake Pad

A: REMOVAL

- 1) Lift-up the vehicle, and then remove the rear wheels.
- 2) Remove the caliper bolt.

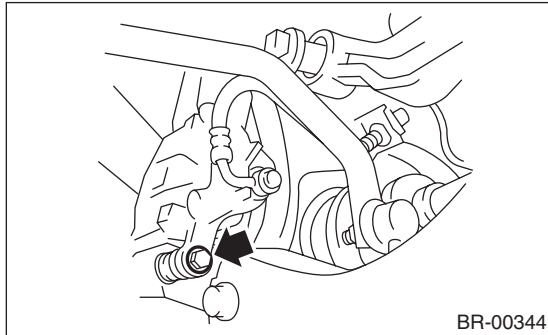

- 3) Raise the caliper body and support it.

NOTE:

Do not disconnect the brake hose from the caliper body.

- 4) Remove the pad.

NOTE:

If it is difficult to remove the brake pad, use the same procedure as front disc brake pad.

<Ref. to BR-13, REMOVAL, Front Brake Pad.>

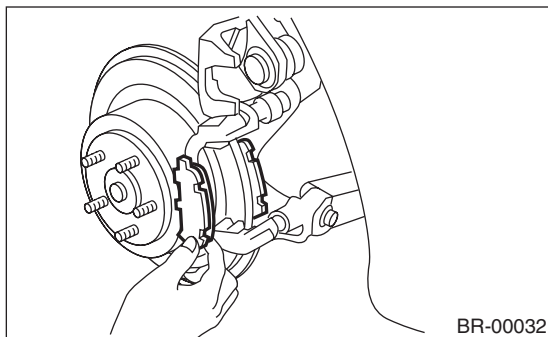

B: INSTALLATION

- 1) Apply a thin coat of Molykote M7439 (Part No. 003602001) to the pad clip.

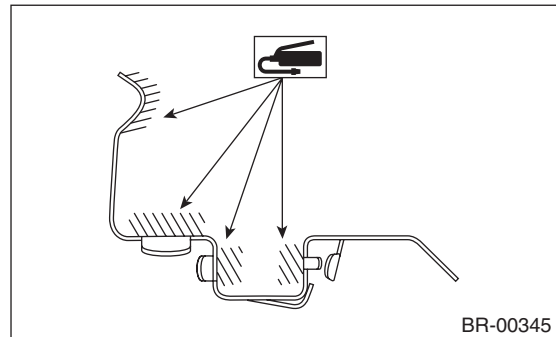

- 2) Apply a thin coat of Molykote AS880N (Part No. K0777YA010) to the contact surface between the pad and shim.
- 3) Install the pad to support.
- 4) Install the caliper body to the support.

Tightening torque:

Solid disc brake model

27 N·m (2.8 kgf-m, 19.9 ft-lb)

Ventilated disc brake model

37 N·m (3.7 kgf-m, 27.2 ft-lb)

C: INSPECTION

Check the pad thickness A.

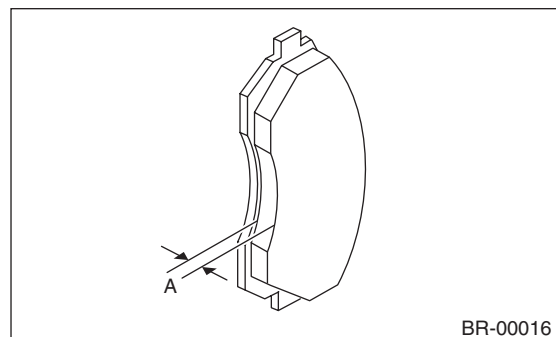

Type of disc rotor		Solid	Ventilated
Pad thickness	Standard	9.0 (0.35)	9.0 (0.35)
	Wear limit	1.5 (0.059)	1.5 (0.059)

NOTE:

- Always replace the pads of both sides as a set.
- Replace pad clips if they are twisted or worn.
- A wear indicator is installed on the inner disc brake pad. If the pad is worn to the limit, the end of wear indicator contacts disc rotor, and a squeaking sound is heard as the wheel rotates. If the sound is heard, replace the pad.
- Replace the pad if there is oil or grease on it.