

## 8. Master Cylinder

### A: REMOVAL

**CAUTION:**

Do not allow brake fluid to come in contact with vehicle body. If it does, wash off with water and wipe away completely.

- 1) Drain brake fluid from reservoir tank completely.
- 2) Disconnect the harness connector of the fluid level gauge.
- 3) Remove the brake pipe from the master cylinder.
- 4) Remove the master cylinder mounting nuts, and remove the master cylinder from the brake booster.

### B: INSTALLATION

- 1) Replace the O-ring for the master cylinder with a new part.

**CAUTION:**

Be careful not to install the O-ring in the wrong location.

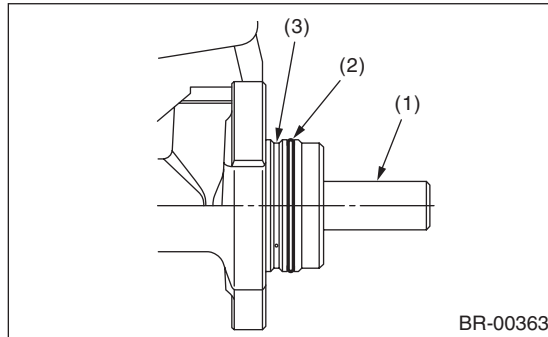

- (1) Primary piston
- (2) O-ring
- (3) Do not install the O-ring on this groove.

- 2) Install in the reverse order of removal.

**Tightening torque:**

**Master cylinder mounting nut**

13 N·m (1.3 kgf·m, 9.6 ft·lb)

**Piping flare nut**

**Model with ABS**

15 N·m (1.5 kgf·m, 10.8 ft·lb)

**Model with VDC**

19 N·m (1.9 kgf·m, 14.0 ft·lb)

**CAUTION:**

Be sure to use recommended brake fluid.

- 3) Bleed air from brake system. <Ref. to BR-33, PROCEDURE, Air Bleeding.>

### C: REPLACEMENT

- 1) Remove mud and dirt from the surface of brake master cylinder.
- 2) Secure the master cylinder in a vise.

**NOTE:**

To avoid damaging the master cylinder, place between aluminum plates or other material when holding with a vise.

- 3) Remove the pin which secures the master cylinder and reservoir tank, then remove the reservoir tank and seal.

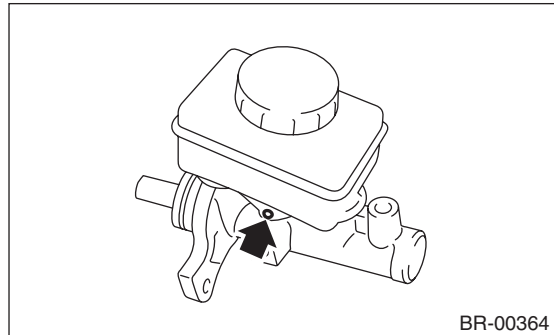

BR-00364

- 4) While pushing in the primary piston, remove the C-ring using pliers.

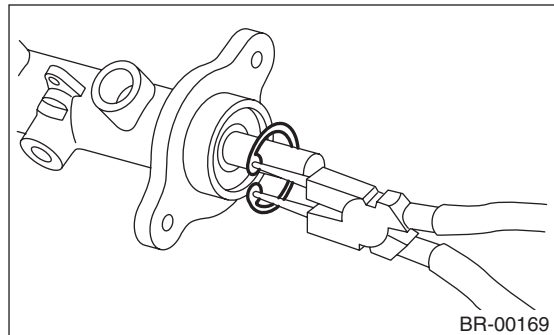

BR-00169

- 5) While pushing in the primary piston, remove the straight pin from the port on the reservoir tank attachment location using a magnet pick-up tool.

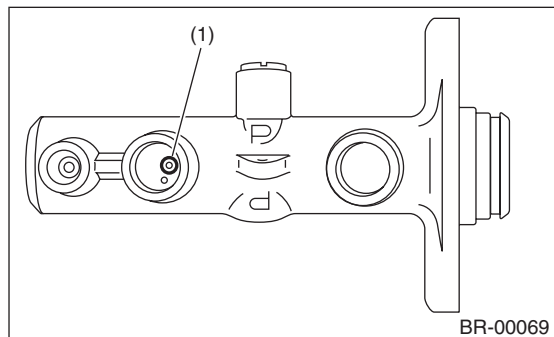

BR-00069

- (1) Straight pin

- 6) Extract the primary piston assembly and secondary piston assembly straight out while taking care not to scratch the inner surface of the cylinder.

7) Clean the inside of master cylinder with brake fluid. Check the inside of the cylinder for damage, deformation and wear. Replace the master cylinder as assembly if faulty.

8) Apply brake fluid to the inner surface of master cylinder and piston assembly.

9) Make sure that the inner surface of master cylinder and the piston assembly are free of foreign matter. Install the primary piston assembly and the secondary piston assembly to master cylinder, while taking care not to scratch the master cylinder inner surface.

10) While pushing-in the primary piston, install the cylinder pin.

11) While pushing-in the primary piston, install the C-ring to the groove using pliers.

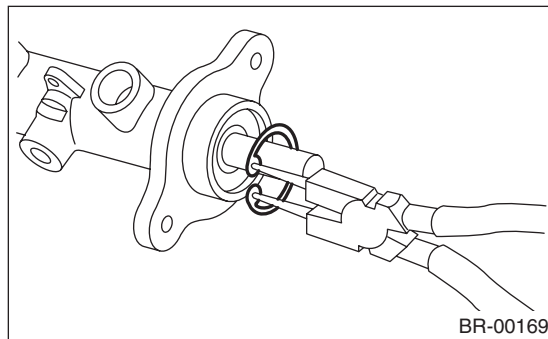

**CAUTION:**  
Make sure the C-ring is installed to the groove securely.

12) Install the seal to reservoir tank.

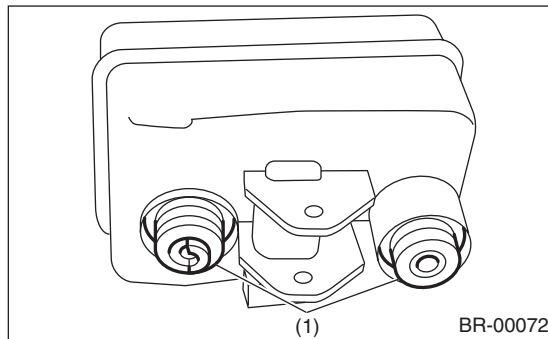

(1) Seal

13) Install the reservoir tank to the master cylinder, and secure with pin.

14) Replace the O-ring for the master cylinder with a new part.

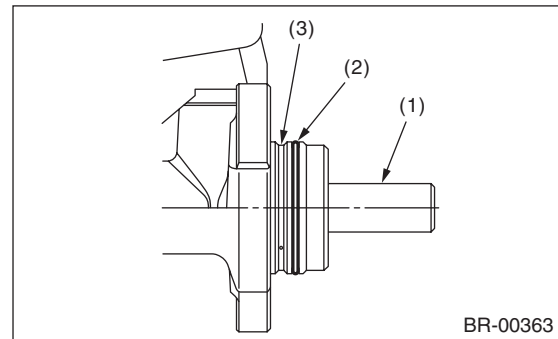

(1) Primary piston

(2) O-ring

(3) Do not install the O-ring on this groove.

## D: INSPECTION

Inspect for oil leakage from the master cylinder.

### NOTE:

After replacing the piston kit, if an oil leakage is found even though there is no damage or scratches on the inside of the cylinder, the master cylinder inner wall may be worn. In this case, replace the master cylinder as an assembly.