

4. Front Hub Unit Bearing

A: REMOVAL

- 1) Disconnect the ground cable from battery.
- 2) Lift-up the vehicle, and remove the front wheels.
- 3) Lift the crimped section of axle nut.

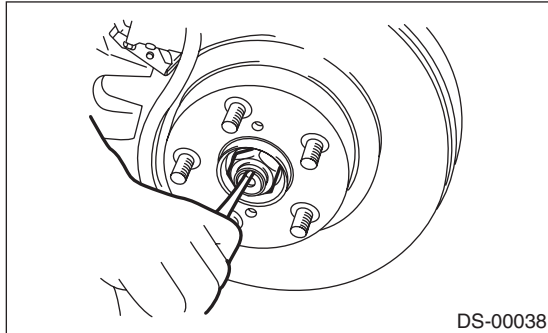

- 4) Remove the axle nut using a socket wrench while depressing the brake pedal.

CAUTION:

Remove the wheel before loosening the axle nut. Failure to follow this rule may damage the wheel bearings.

- 5) Remove the disc brake caliper from the housing, and suspend it from strut using a wire.
- 6) Remove the disc rotor from the hub.

NOTE:

If it is difficult to remove the disc rotor from the hub, drive the 8 mm bolt into the threaded end of rotor, and then remove the rotor.

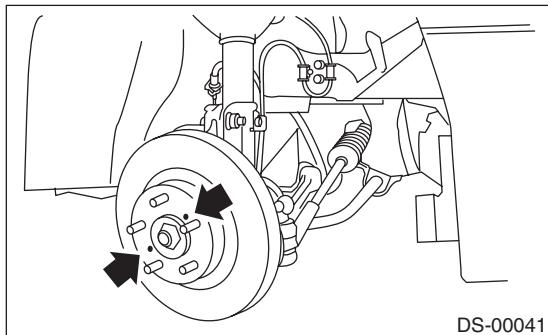

- 7) Remove the four bolts from the housing.

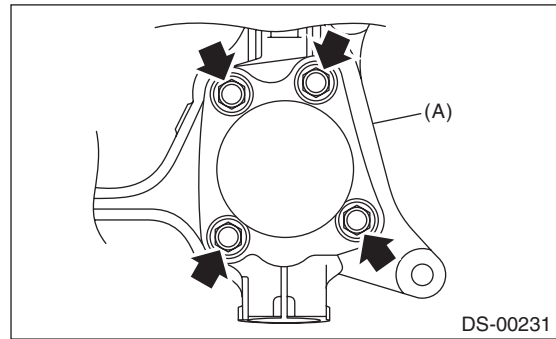

(A) Housing

CAUTION:

- Do not get closer the tool which charged magnetism to magnetic encoder.
- Be careful not to damage the magnetic encoder.

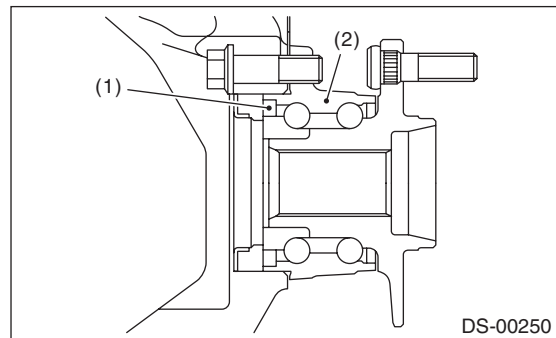

- (1) Magnetic encoder
- (2) Front hub unit bearing

- 8) Remove the front hub unit bearing. If it is hard to remove, use the ST.

ST1 926470000 AXLE SHAFT PULLER
 ST2 28099PA110 AXLE SHAFT PULLER PLATE

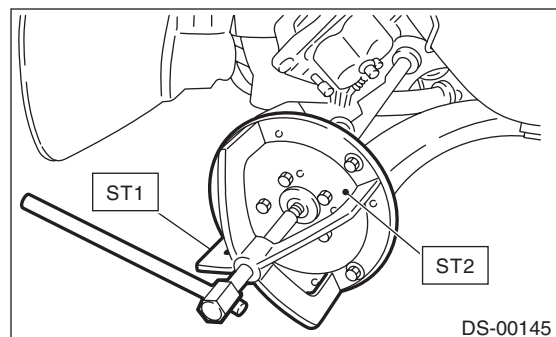

Front Hub Unit Bearing

DRIVE SHAFT SYSTEM

B: INSTALLATION

1) Place the disc cover between housing and front hub unit, and tighten the four bolts.

Tightening torque:

65 N-m (6.6 kgf-m, 47.9 ft-lb)

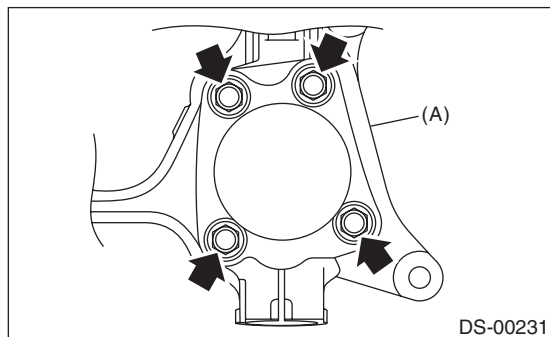

(A) Housing

- 2) Install the front drive shaft. <Ref. to DS-22, INSTALLATION, Front Drive Shaft.>
- 3) Tighten the axle nut temporarily.
- 4) Install the disc rotor to hub.
- 5) Install the disc brake caliper on the housing.

Tightening torque:

80 N-m (8.2 kgf-m, 59 ft-lb)

- 6) While depressing the brake pedal, tighten a new axle nut (olive color) to the specified torque and lock it securely.

Tightening torque:

220 N-m (22.4 kgf-m, 162 ft-lb)

CAUTION:

- Install the wheel after installation of axle nut. Failure to follow this rule may damage the wheel bearing.
- Be sure to tighten the axle nut to specified torque. Do not overtighten it as this may damage the wheel bearing.

- 7) After tightening the axle nut, lock it securely.

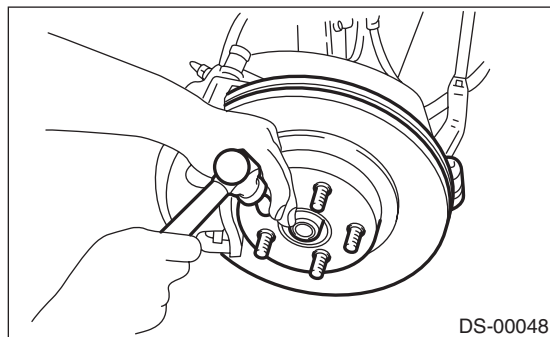

- 8) Install the wheel and tighten the wheel nuts to specified torque.

Tightening torque:

110 N-m (11.2 kgf-m, 81.1 ft-lb)

C: DISASSEMBLY

Using the ST and a hydraulic press, push out the hub bolts.

ST 28399AG000 HUB STAND

CAUTION:

- Be careful not to hammer the hub bolts. This may deform the hub.
- Do not reuse the hub bolt.

NOTE:

Since the hub unit bearing can not be disassembled, only hub bolts can be removed.

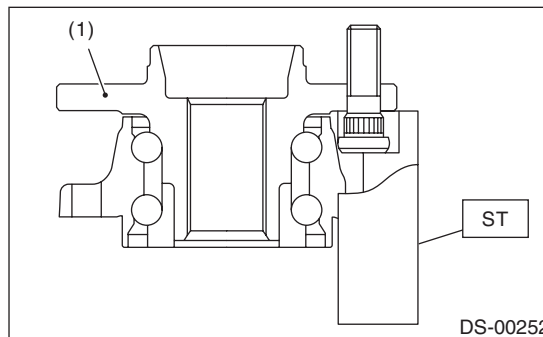

(1) Front hub unit bearing

D: ASSEMBLY

- 1) Attach the hub to the ST securely.

ST 927080000 HUB STAND

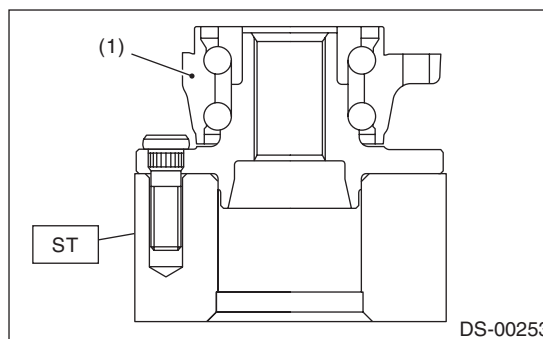

(1) Front hub unit bearing

- 2) Using a press, press the new hub bolts until their seating surfaces contact the hub.

NOTE:

Use the 12 mm (0.47 in) dia. holes in the HUB STAND to prevent bolts from tilting.

E: INSPECTION

Refer to "Front Axle" for inspection procedures. <Ref. to DS-16, INSPECTION, Front Axle.>

CAUTION:

If there is any fault in the bearing, replace hub unit bearing.