

## 5. Rear Hub Unit Bearing

### A: REMOVAL

- 1) Disconnect the ground cable from battery.
- 2) Lift-up the vehicle, and then remove the rear wheels.
- 3) Lift the crimped section of axle nut.

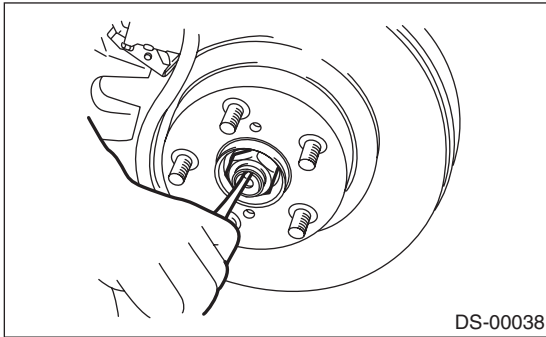

- 4) While applying the parking brake, remove the axle nut using a socket wrench.

**CAUTION:**

Remove the wheel before loosening the axle nut. Failure to follow this rule may damage the wheel bearings.

- 5) Release the parking brake.
- 6) Remove the rear ABS wheel speed sensor.

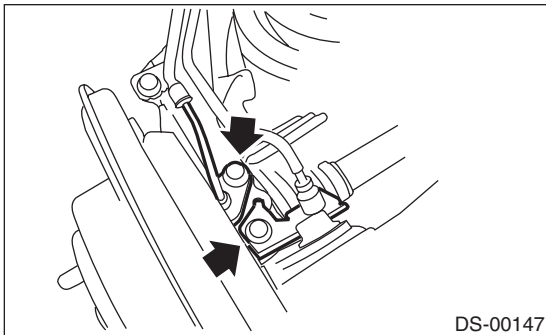

- 7) Remove the disc brake caliper from back plate, and suspend it from the stabilizer using a wire.

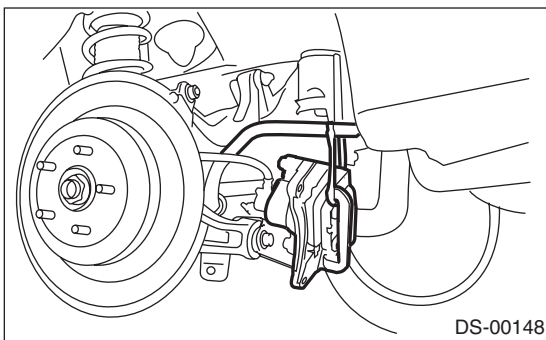

- 8) Remove the disc rotor from the hub.

**NOTE:**

- Mark the mating surface of hub and disc rotor before removing the disc rotor to avoid confusing when installing.
- If it is difficult to remove the disc rotor from the hub, drive an 8 mm bolt into the threaded end of rotor, and then remove the rotor.

- 9) Remove the four bolts from rear arm.

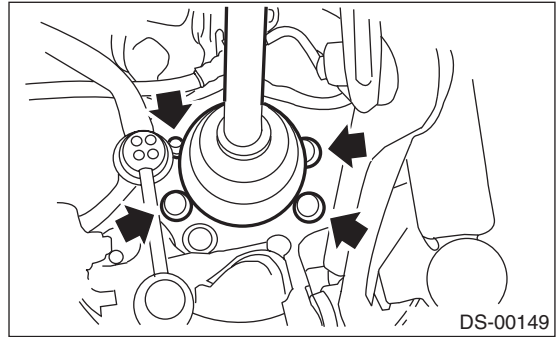

- 10) Remove the hub unit bearing.

**CAUTION:**

- Be careful not to damage the magnetic encoder.
- Do not get closer the tool which charged magnetism to magnetic encoder.

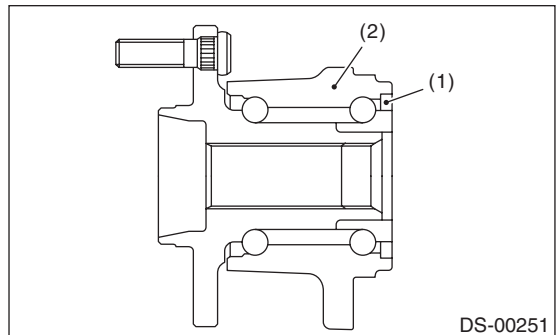

- (1) Magnetic encoder
- (2) Rear hub unit bearing

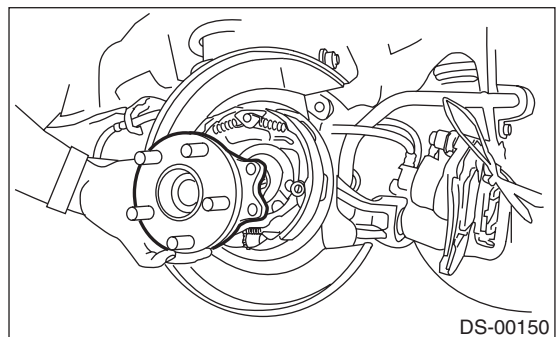

# Rear Hub Unit Bearing

## DRIVE SHAFT SYSTEM

### NOTE:

If it is hard to remove, use the ST.

ST1 926470000 AXLE SHAFT PULLER  
ST2 927140000 AXLE SHAFT PULLER  
PLATE

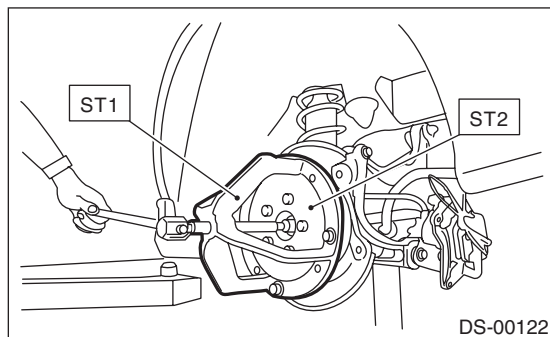

## B: INSTALLATION

1) Aligning the hub unit bearing to the mounting hole of the back plate, install the hub unit assembly and back plate. Tighten the axle nut temporarily.

### CAUTION:

- Be careful not to damage the magnetic encoder.
- Do not get closer the tool which charged magnetism to magnetic encoder.

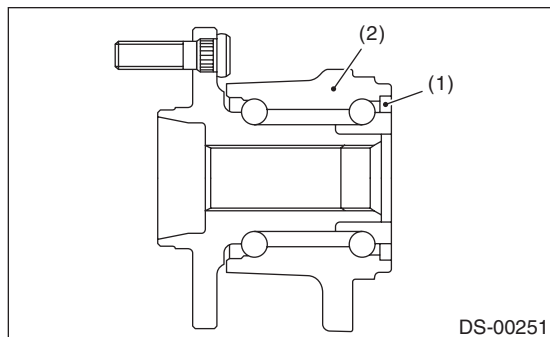

- (1) Magnetic encoder  
(2) Rear hub unit bearing

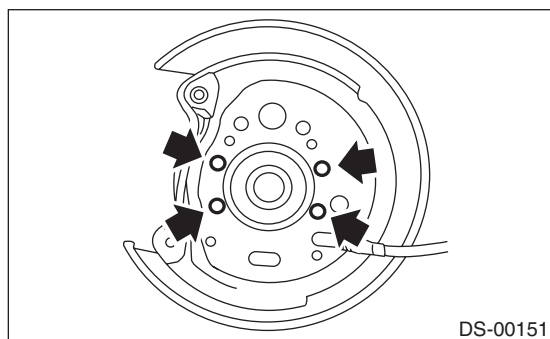

2) Tighten the four bolts to the back plate.

### Tightening torque:

**65 N·m (6.6 kgf·m, 47.9 ft·lb)**

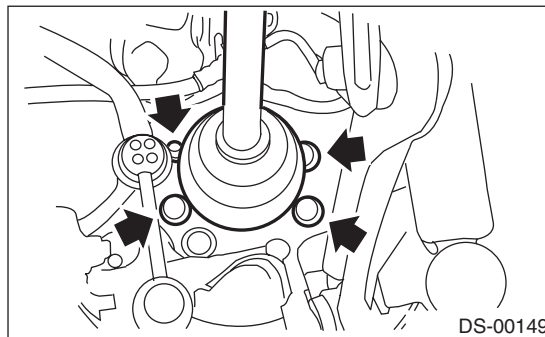

3) Remove the axle nut.

4) Draw the rear drive shaft into specified position.

5) Tighten the new axle nut temporarily.

### CAUTION:

**Use a new axle nut (olive color).**

6) Install the disc rotor to hub.

7) Install the disc brake caliper on the back plate.

### Tightening torque:

**53 N·m (5.4 kgf·m, 39.1 ft·lb)**

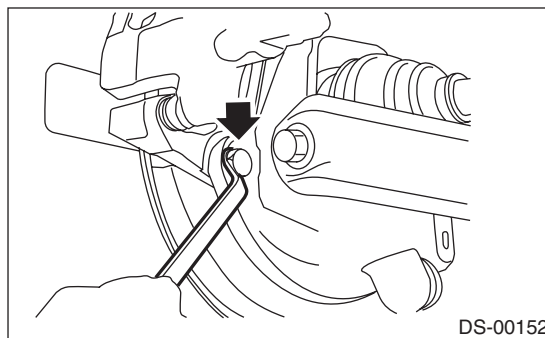

8) Install the rear ABS wheel speed sensor and brake cable bracket.

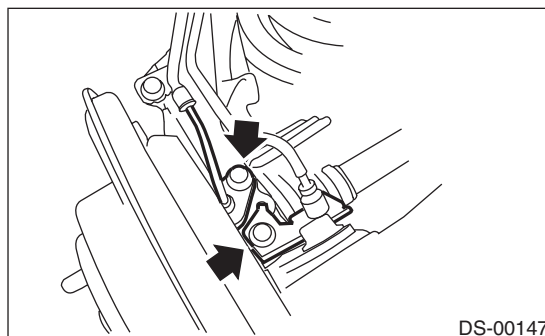

9) Adjust the parking brake lever stroke by turning the adjuster. <Ref. to PB-4, ADJUSTMENT, Parking Brake Lever.>

10) While applying the parking brake and depressing the brake pedal, tighten a new axle nut (olive color) to the specified torque and lock it securely.

**Tightening torque:**

**240 N·m (24.5kgf·m, 177 ft·lb)**

**CAUTION:**

- Install the wheel after installation of axle nut. Failure to follow this rule may damage the wheel bearing.
- Be sure to tighten the axle nut to specified torque. Do not overtighten it as this may damage the wheel bearing.

11) After tightening the axle nut, lock it securely.

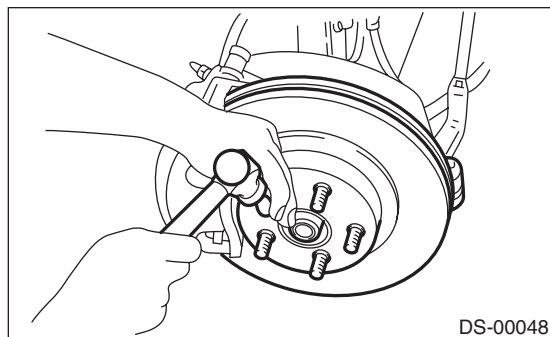

12) Install the wheel and tighten the wheel nuts to specified torque.

**Tightening torque:**

**110 N·m (11.2 kgf·m, 81.1 ft·lb)**

**C: DISASSEMBLY**

Using the ST and a hydraulic press, push out the hub bolts.

ST 28399AG000 HUB STAND

**CAUTION:**

- Be careful not to hammer the hub bolts. This may deform the hub.
- Do not reuse the hub bolt.

**NOTE:**

Since the hub unit bearing can not be disassembled, only hub bolts can be removed.

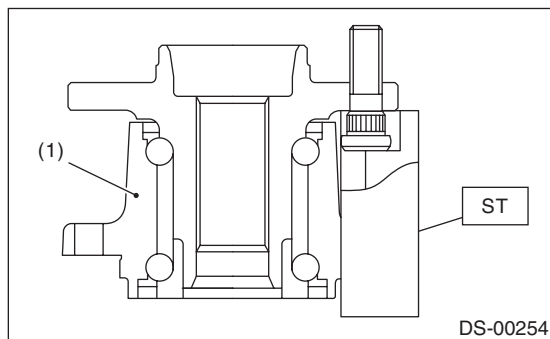

(1) Rear hub unit bearing

**D: ASSEMBLY**

1) Attach the hub to the ST securely.

ST 927080000 HUB STAND

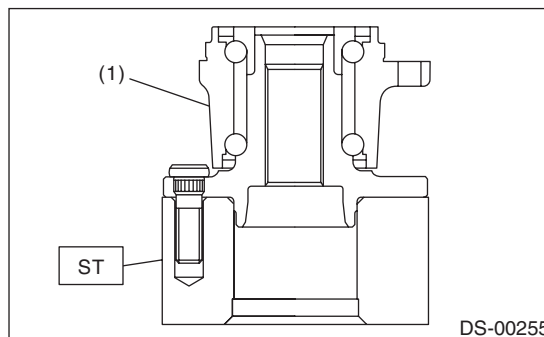

(1) Rear hub unit bearing

2) Using a press, press the new hub bolts until their seating surfaces contact the hub.

**NOTE:**

Use the 12 mm (0.47 in) dia. holes in the HUB STAND to prevent bolts from tilting.

**E: INSPECTION**

1) Moving the rear tire up and down by hand, check there is no backlash in bearing, and check the wheel rotates smoothly.

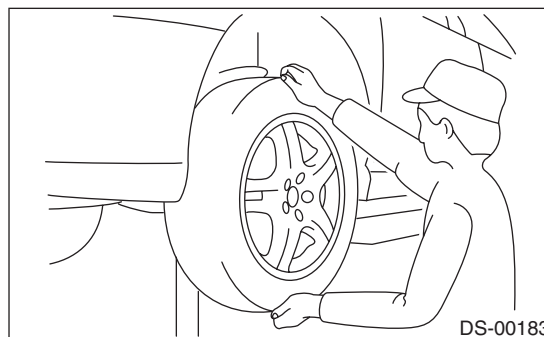

2) Inspect the lean of axis direction using a dial gauge. Replace the hub bearing if the play exceeds the limit value.

**Service limit:**

**Maximum: 0.05 mm (0.0020 in)**

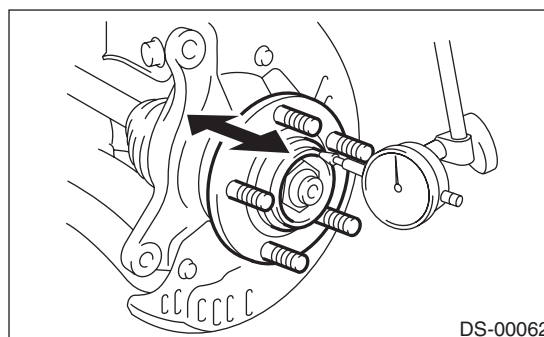

DS-00062