

# Rear Drive Shaft

## DRIVE SHAFT SYSTEM

### 7. Rear Drive Shaft

#### A: REMOVAL

- 1) Disconnect the ground cable from battery.
- 2) Lift-up the vehicle, and then remove the rear wheels.
- 3) Lift the crimped section of axle nut.

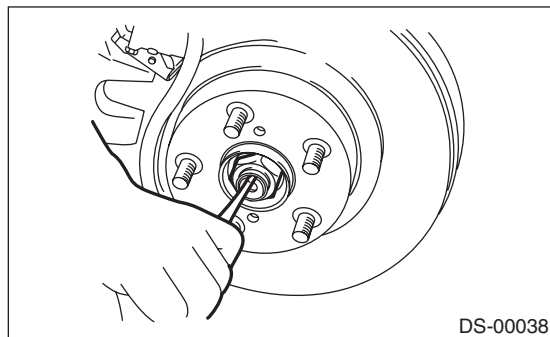

- 4) While applying the parking brake, remove the axle nut using a socket wrench.

#### CAUTION:

**Remove the wheel before loosening the axle nut. Failure to follow this rule may damage the wheel bearings.**

- 5) Remove the rear differential assembly.

- T-type

<Ref. to DI-27, REMOVAL, Rear Differential (T-type).>

- VA-type

<Ref. to DI-44, REMOVAL, Rear Differential (VA-type).>

- 6) Remove the axle nut and rear drive shaft. If it is hard to remove, use ST1 and ST2.

ST1 926470000 AXLE SHAFT PULLER

ST2 927140000 AXLE SHAFT PULLER  
PLATE

#### CAUTION:

- Do not hammer drive shaft when removing.
- Do not damage the oil seal and magnetic encoder.

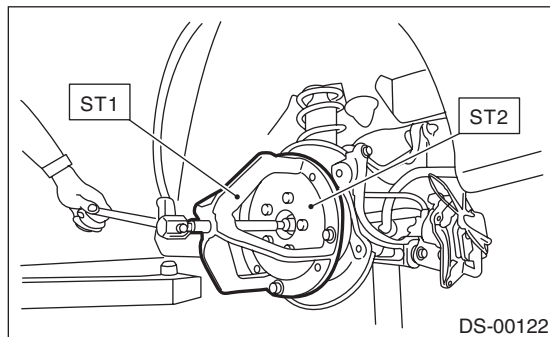

#### B: INSTALLATION

- 1) Insert the BJ or EBJ into the rear hub splines.

#### CAUTION:

- Be careful not to damage the magnetic encoder.
- Do not get closer the tool which charged magnetism to magnetic encoder.

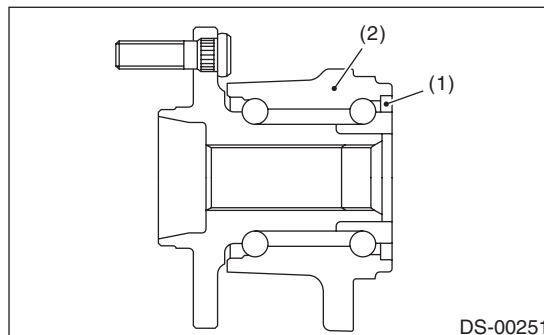

(1) Magnetic encoder

(2) Rear hub unit bearing

- 2) Draw the rear drive shaft into specified position.

#### CAUTION:

**Do not hammer drive shaft when installing it.**

- 3) Tighten the axle nut temporarily.

- 4) Install the rear differential assembly.

- T-type

<Ref. to DI-28, INSTALLATION, Rear Differential (T-type).>

- VA-type

<Ref. to DI-45, INSTALLATION, Rear Differential (VA-type).>

- 5) While applying the parking brake and depressing the brake pedal, tighten a new axle nut (olive color) to the specified torque and lock it securely.

#### Tightening torque:

**240 N·m (24.5 kgf·m, 177 ft·lb)**

#### CAUTION:

- Install the wheel after installation of axle nut. Failure to follow this rule may damage the wheel bearing.
- Be sure to tighten the axle nut to specified torque. Do not overtighten it as this may damage the wheel bearing.

6) Lock the axle nut securely.

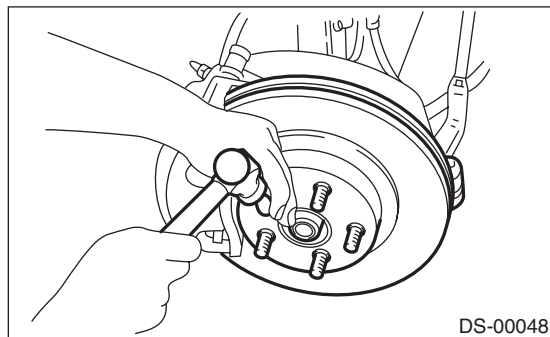

7) Install the wheel.

**Tightening torque:**

**110 N·m (11.2 kgf·m, 81.1 ft·lb)**

## C: DISASSEMBLY

1) Straighten the bent claw at the larger end of the DOJ boot.

2) Loosen the band by means of screwdriver or pliers.

**CAUTION:**

**Be careful not to damage the boot.**

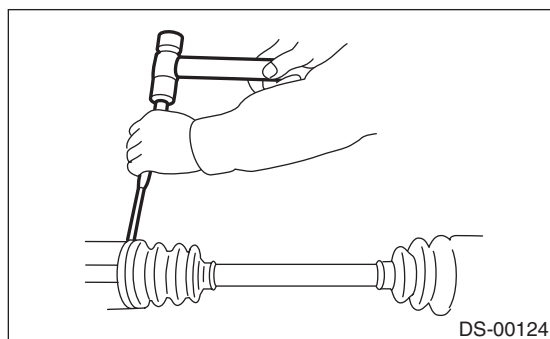

3) Remove the boot band on the small end of DOJ boot in the same manner.

4) Remove the larger end of DOJ boot from DOJ outer race.

5) Pry and remove the round circlip at the neck of DOJ outer race with a screwdriver.

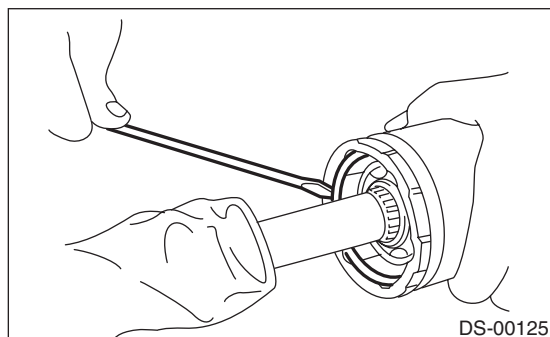

6) Take out the DOJ outer race from the shaft assembly.

7) Wipe off the grease and take out the ball bearings.

**CAUTION:**

**The grease is a special grease (grease for constant velocity joints). Do not mix with other greases.**

**NOTE:**

Disassemble exercising care not to lose balls (6 pcs).

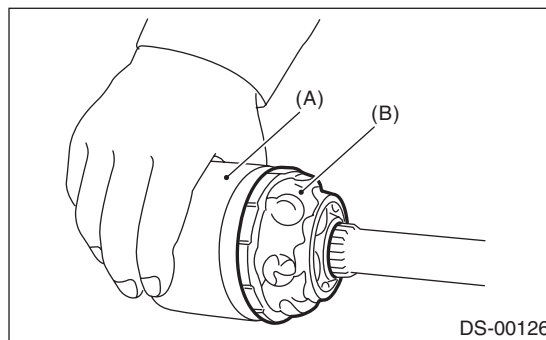

(A) Outer race

(B) Grease

8) To remove the cage from inner race, turn the cage by a half pitch to the track groove of inner race and shift the cage.

9) Using pliers, remove the snap ring fixing the inner race to the shaft.

10) Take out the DOJ inner race.

11) Take off the DOJ cage from shaft and remove the DOJ boot.

**CAUTION:**

**Be sure to wrap shaft splines with vinyl tape to prevent boot from scratches.**

12) Remove the BJ boot or EBJ boot in the same procedure as the DOJ boot.

**NOTE:**

Further disassembly of axle is impossible because the BJ and EBJ cannot be disassembled.

# Rear Drive Shaft

## DRIVE SHAFT SYSTEM

### D: ASSEMBLY

#### NOTE:

Use specified grease.

#### BJ side:

**NTG2218-M (Part No. 28395AG01A)**

#### EBJ side

**NTG2218-M (Part No. 28395AG01A)**

#### DOJ side:

**NKG205 (Part No. 28495AG00A)**

1) Install the BJ or EBJ boot in specified position, and fill it with 60 to 70 g (2.12 to 2.47 oz.) of specified grease.

2) Place the DOJ cage onto shaft.

#### CAUTION:

**Be sure to wrap shaft splines with vinyl tape to prevent boot from scratches.**

3) Insert the DOJ cage onto shaft.

#### NOTE:

Insert the cage with the cutout portion facing the shaft end, since the cage has an orientation.

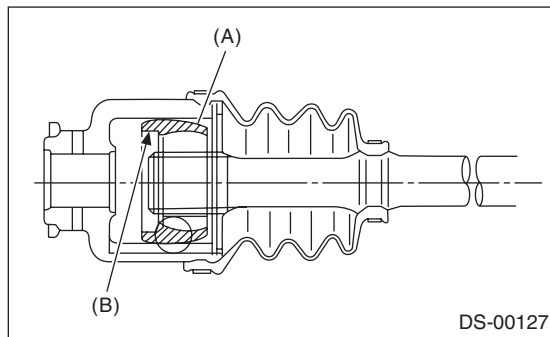

(A) Cage  
(B) Cutout portion

4) Install the DOJ inner race on shaft and fix the snap ring in place with pliers.

#### NOTE:

Confirm that the snap ring is completely fitted in the shaft groove.

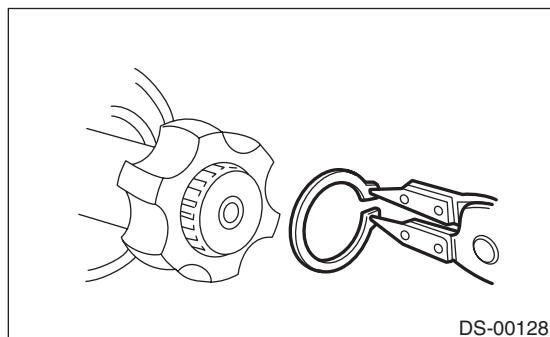

DS-00128

5) Install the cage to inner race fixed upon shaft.

#### NOTE:

Fit the cage with the protruding section aligned with the track on the inner race, and turn by a half pitch.

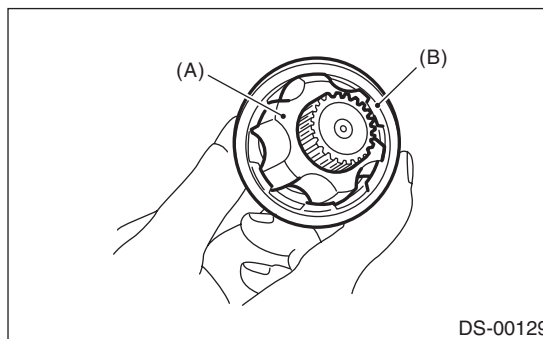

(A) Inner race  
(B) Cage

6) Fill 80 to 90 g (2.82 to 3.17 oz) of specified grease into the inner side of the DOJ outer race.

7) Apply a thin coat of specified grease to the cage pocket and six ball bearings.

8) Insert the six ball bearings into the cage pocket.

9) Align the outer race track and ball positions, and place the shaft, inner race, cage and ball bearings in the original positions, and then fix outer race in place.

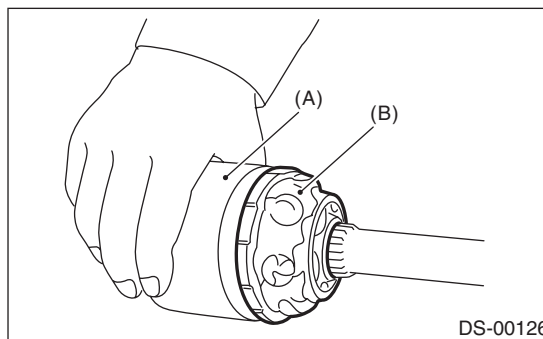

(A) Outer race  
(B) Grease

10) Install the snap ring in the groove on the DOJ outer race.

**NOTE:**

- Assure that the balls, cage and inner race are completely fitted in the outer race of DOJ.
- Use care not to place the matched position of snap ring in the ball groove of outer race.
- Pull the shaft lightly and assure that the circlip is completely fitted in the groove.

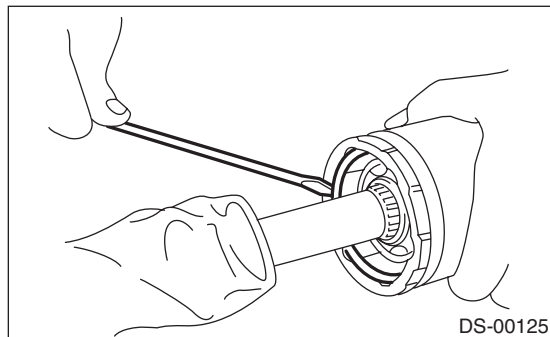

11) Apply an even coat of the specified grease [20 to 30 g (0.71 to 1.06 oz)] to the entire inner surface of boot. Also apply grease to the shaft.

12) Install the DOJ boot taking care not to twist it.

**NOTE:**

- The inside of the larger end of DOJ boot and the boot groove shall be cleaned so as to be free from grease and other substances.
- When installing the DOJ boot, position the outer race of DOJ at center of the stroke.

13) Put a new band through the clip and wind twice in the band groove of the boot.

14) Pinch the end of band with pliers. Hold the clip and tighten securely.

**NOTE:**

When tightening boot, use care so that the air within the boot is appropriate.

15) Tighten the band using the ST.

ST 925091000 BAND TIGHTENING TOOL

**NOTE:**

Tighten the band until it cannot be moved by hand.

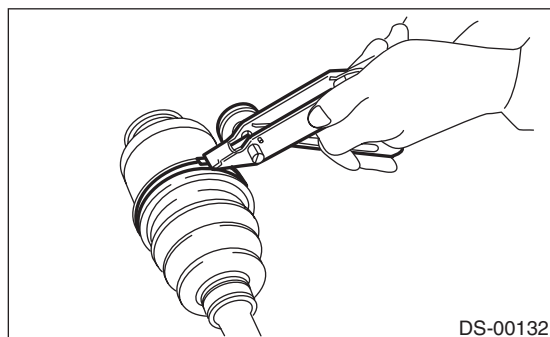

16) Tap the clip with the punch provided at the end of the ST.

ST 925091000 BAND TIGHTENING TOOL

**NOTE:**

Tap to an extent that the boot underneath is not damaged.

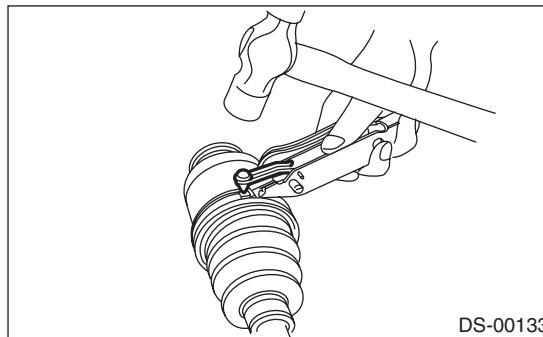

17) Cut off the band with an allowance of about 10 mm (0.39 in) left from the clip and bend this allowance over the clip.

**NOTE:**

Be careful so that the end of the band is in close contact with clip.

18) Install the BJ boot or EBJ boot in the same procedure as a DOJ boot.

19) Extend and retract the DOJ repeatedly to provide an equal coating of grease.

## E: INSPECTION

Check the removed parts for damage, wear, corrosion etc. Repair or replace if defective.

- DOJ (Double Offset Joint)
  - Check for seizure, corrosion, damage, wear and excessive play.
- EBJ (high-efficiency compact ball fixed joint)
  - Check for seizure, corrosion, damage, wear and excessive play.
- Shaft
  - Check for excessive bending, twisting, damage and wear.
- BJ (Bell Joint)
  - Check for seizure, corrosion, damage and excessive play.
- Boot
  - Check for wear, warping, breakage and scratches.
- Grease
  - Check for discoloration and fluidity.