

8. Front Crossmember

A: REMOVAL

- 1) Lift-up the vehicle, and then remove the front wheels.
- 2) Remove the front exhaust pipe.
- 3) Remove the front crossmember support plate. <Ref. to FS-13, REMOVAL, Front Crossmember Support Plate.>
- 4) Remove the front stabilizer. <Ref. to FS-14, REMOVAL, Front Stabilizer.>
- 5) Disconnect the tie-rod end from housing.
- 6) Remove the front arm. <Ref. to FS-17, REMOVAL, Front Arm.>
- 7) Remove the nuts attaching the engine mount cushion rubber to crossmember.

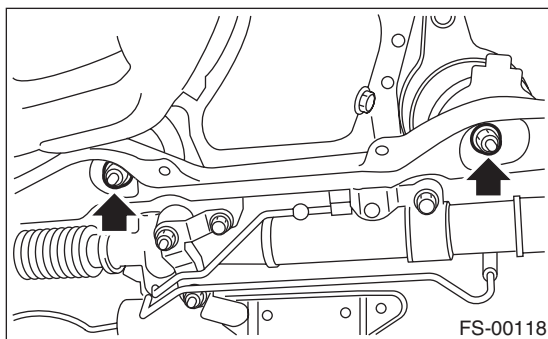

- 8) Remove the steering universal joint.
- 9) Disconnect the power steering hose from steering gearbox.
- 10) Lift the engine approx. 10 mm (0.39 in) using a chain block.
- 11) Support the crossmember with a jack, remove the bolts securing crossmember to body, and then gradually lower the crossmember with steering gearbox as a unit.

CAUTION:

When removing the crossmember downward, be careful that the tie-rod end does not interfere with drive shaft boot.

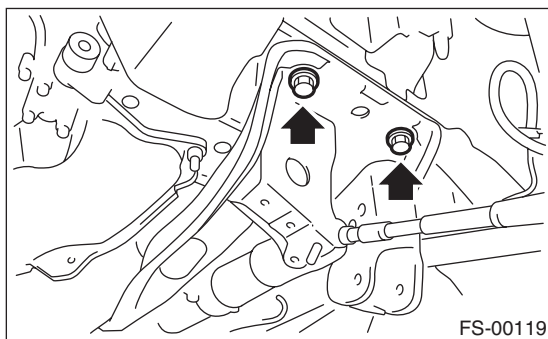

B: INSTALLATION

- 1) Install in the reverse order of removal.

NOTE:

- Use a new bolt and self-locking nut. For parts which are not reusable, refer to "COMPONENT". <Ref. to FS-3, COMPONENT, General Description.>
- Always tighten the stabilizer bushing in the state where the vehicle is at curb weight and the wheels are in full contact with the ground.

Tightening torque:

Crossmember to body:

95 N·m (9.7 kgf-m, 70.1 ft-lb)

Engine mounting to Crossmember:

75 N·m (7.6 kgf-m, 55.3 ft-lb)

Front arm to Crossmember:

95 N·m (9.7 kgf-m, 70.1 ft-lb)

Front arm to Support plate:

110 N·m (11.2 kgf-m, 81.1 ft-lb)

Support plate to Body:

150 N·m (15.3 kgf-m, 110.6 ft-lb)

Tie-rod end to Housing:

27.0 N·m (2.75 kgf-m, 19.9 ft-lb)

After tightening to the specified torque, tighten the castle nut further but within 60° until the hole in the ball stud is aligned with a slot in castle nut

Universal joint:

24 N·m (2.4 kgf-m, 17.4 ft-lb)

Stabilizer bracket:

25 N·m (2.5 kgf-m, 18.1 ft-lb)

Stabilizer link:

45 N·m (4.6 kgf-m, 33.2 ft-lb)

Power steering hose to Steering gearbox:

15 N·m (1.5 kgf-m, 11 ft-lb)

- 2) Purge air from the power steering system.
- 3) Inspect the wheel alignment and adjust if necessary.

C: INSPECTION

Check the crossmember for wear, damage or cracks, and then repair or replace if faulty.