

Parking Brake Assembly (Rear Disc Brake)

PARKING BRAKE

4. Parking Brake Assembly (Rear Disc Brake)

A: REMOVAL

- 1) Release the parking brake.
- 2) Remove the two mounting bolts and remove the brake caliper assembly.

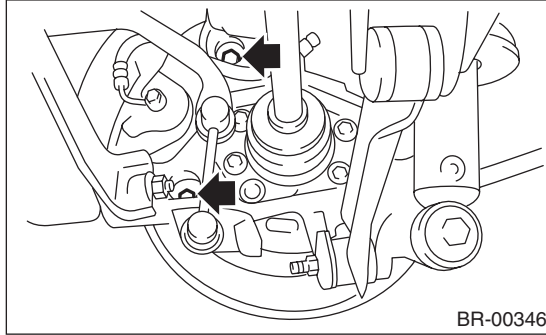

- 3) Suspend the brake caliper assembly so that the hose is not stretched.
- 4) Remove the disc rotor.

NOTE:

If the disc rotor is difficult to remove, try the following two methods in order.

- (1) Turn the adjusting screw using a flat tip screwdriver until the brake shoe moves adequately away from the disc rotor.

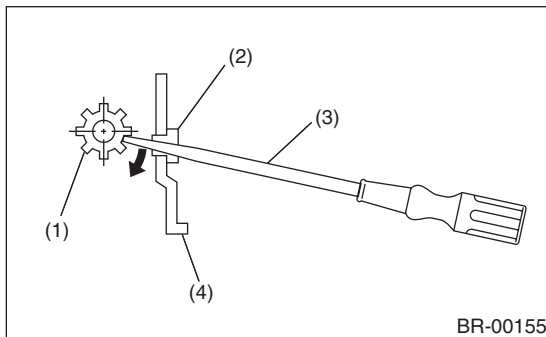

- (1) Adjuster
- (2) Adjusting hole cover (rubber)
- (3) Flat tip screwdriver
- (4) Back plate

- (2) If disc rotor is seized on the hub, drive the disc rotor out by pushing two 8 mm bolts in holes B on the rotor.

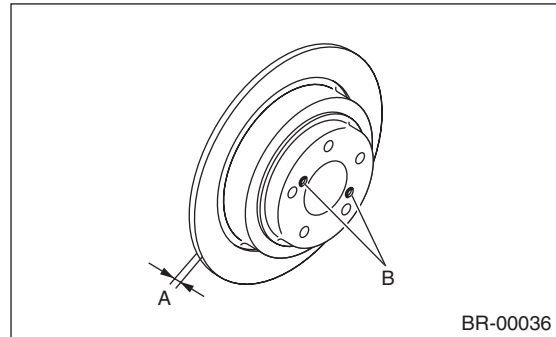

- 5) Remove the shoe return spring from the parking brake assembly.
- 6) Remove the front shoe hold down spring and pin.

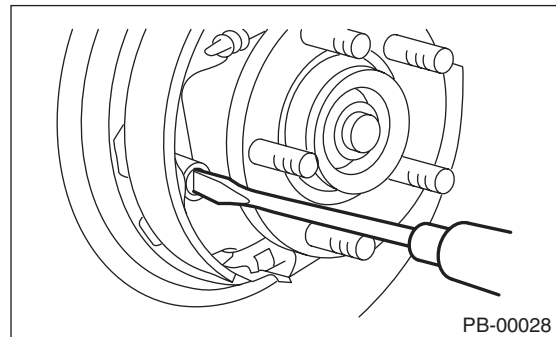

- 7) Remove the strut and strut spring.
- 8) Remove the adjuster assembly from the parking brake assembly.
- 9) Remove the brake shoe.
- 10) Remove the rear shoe hold down spring and pin with pliers.
- 11) Remove the parking brake cable from lever.

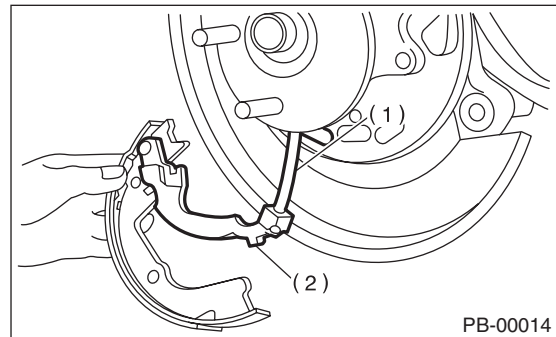

- (1) Parking brake cable
- (2) Lever

- 12) Using a flat tip screwdriver, raise the retainer. Remove the parking lever and washer from brake shoe.

B: INSTALLATION

CAUTION:

Be sure the lining surface is free from oil and grease.

1) Apply brake grease to the following locations.

Brake grease:

Brake Grease (Part No. 003602002)

- Six contact surfaces of the shoe rim and back plate packing
- Contact surface of the shoe wave and the anchor pin
- Contact surface of the lever and strut
- Contact surface of the shoe wave and the adjuster assembly
- Contact surface of the shoe wave and the strut
- Contact surface of the lever and the shoe wave

2) Insert the primary side brake shoe into the anchor pin groove.

3) Secure the brake shoe with the shoe hold-down pin and cup.

4) Install the plate to the anchor pin, then install the primary return spring.

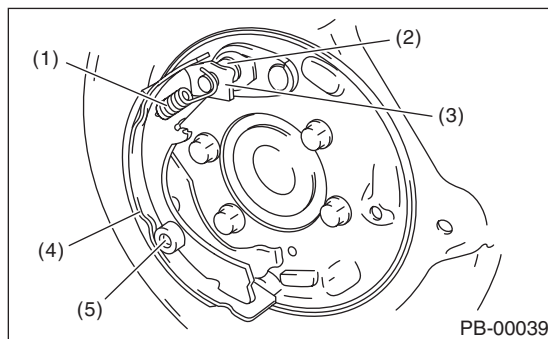

- (1) Primary return spring
- (2) Anchor pin
- (3) Plate
- (4) Primary shoe
- (5) Shoe hold-down pin and shoe hold-down cup

5) Install the parking brake cable to the lever.

6) Install the strut and adjuster, then secure the secondary side brake shoe with the shoe hold-down pin and cup.

NOTE:

- Install the strut spring of both right and left wheel facing vehicle front.
- Install the adjuster assembly with screw section on the left side.

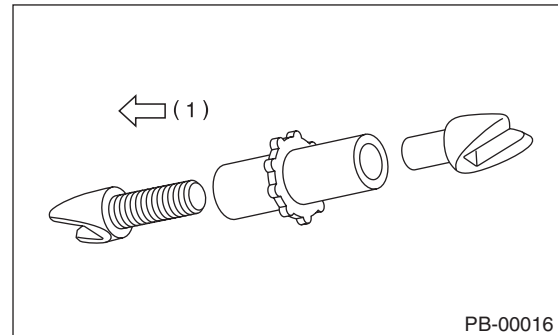

(1) LH

7) Install the secondary return spring and the adjusting spring.

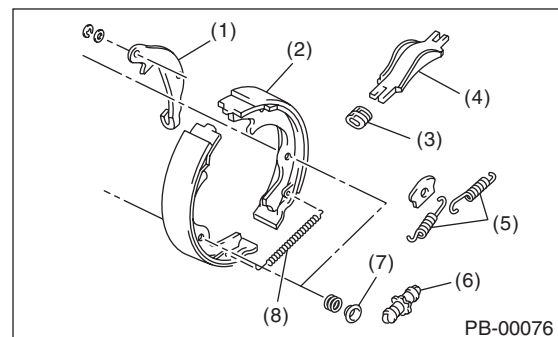

- (1) Lever
- (2) Secondary brake shoe
- (3) Strut spring
- (4) Strut
- (5) Return spring
- (6) Adjuster
- (7) Shoe hold-down cup
- (8) Adjusting spring

8) Adjust the parking brake. <Ref. to PB-8, ADJUSTMENT, Parking Brake Assembly (Rear Disc Brake).>

Parking Brake Assembly (Rear Disc Brake)

PARKING BRAKE

9) Drive the vehicle to break-in the parking brake lining.

(1) Drive the vehicle at about 35 km/h (22 MPH).

(2) With the parking brake release button pushed in, pull the parking brake lever gently.

(3) Drive the vehicle for about 200 m (0.12 mile) in this condition.

(4) Wait 5 to 10 minutes for the parking brake to cool down. Repeat again from step (1).

(5) After breaking-in, re-adjust the parking brakes.

C: INSPECTION

1) Measure the brake disc rotor inside diameter. If the disc is scored or worn, replace the brake disc rotor.

Disc rotor inside diameter:

Standard:

170 mm (6.69 in)

Service limit:

171 mm (6.73 in)

2) Measure the lining thickness. If it exceeds the limit, replace shoe assembly.

Lining thickness:

Standard:

3.2 mm (0.126 in)

Service limit:

1.5 mm (0.059 in)

NOTE:

Replace the right and left brake shoe as a set.

D: ADJUSTMENT

1. SHOE CLEARANCE

1) Return the parking brake lever fully.

2) Remove the adjusting hole cover from the back plate.

3) Turn the adjusting screw using a flat tip screwdriver until the brake shoe is in close contact with the disc rotor.

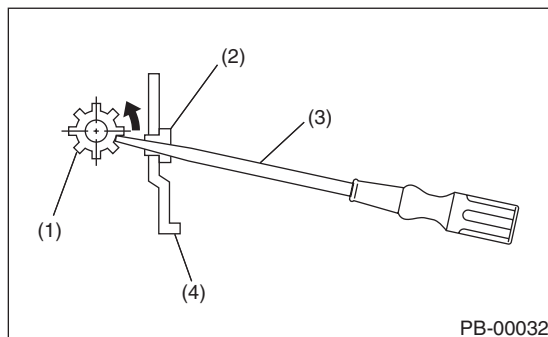

- (1) Adjusting screw
- (2) Adjusting hole cover (rubber)
- (3) Flat tip screwdriver
- (4) Back plate

4) Turn back (downward) the adjusting screw 3 to 4 notches.

CAUTION:

Check there is no brake drag.

5) Install the adjusting hole cover to the back plate.

6) Adjust the parking lever stroke. <Ref. to PB-8, LEVER STROKE, ADJUSTMENT, Parking Brake Assembly (Rear Disc Brake).>

2. LEVER STROKE

1) Adjust the shoe clearance before adjusting lever stroke. <Ref. to PB-8, SHOE CLEARANCE, ADJUSTMENT, Parking Brake Assembly (Rear Disc Brake).>

2) Remove the parking lever cover.

3) Operate the parking brake lever 3 to 4 times.

4) Turn the adjusting nut until the lever stroke is at the specified value.

Lever stroke:

5 to 6 notches when pulled with a force of 200 N (20.4 kgf, 45 lb)

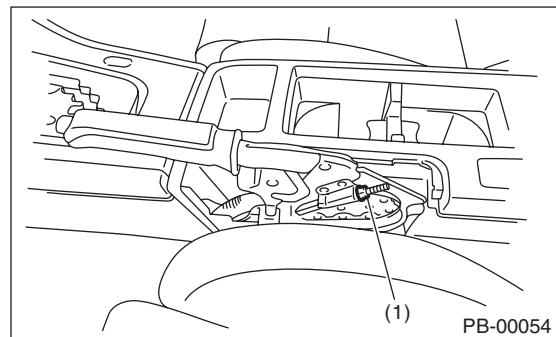

(1) Adjusting nut (Self-locking nut)

5) Check there is no brake drag.

6) Install the parking lever cover.