

Tilt Steering Column

POWER ASSISTED SYSTEM (POWER STEERING)

4. Tilt Steering Column

A: REMOVAL

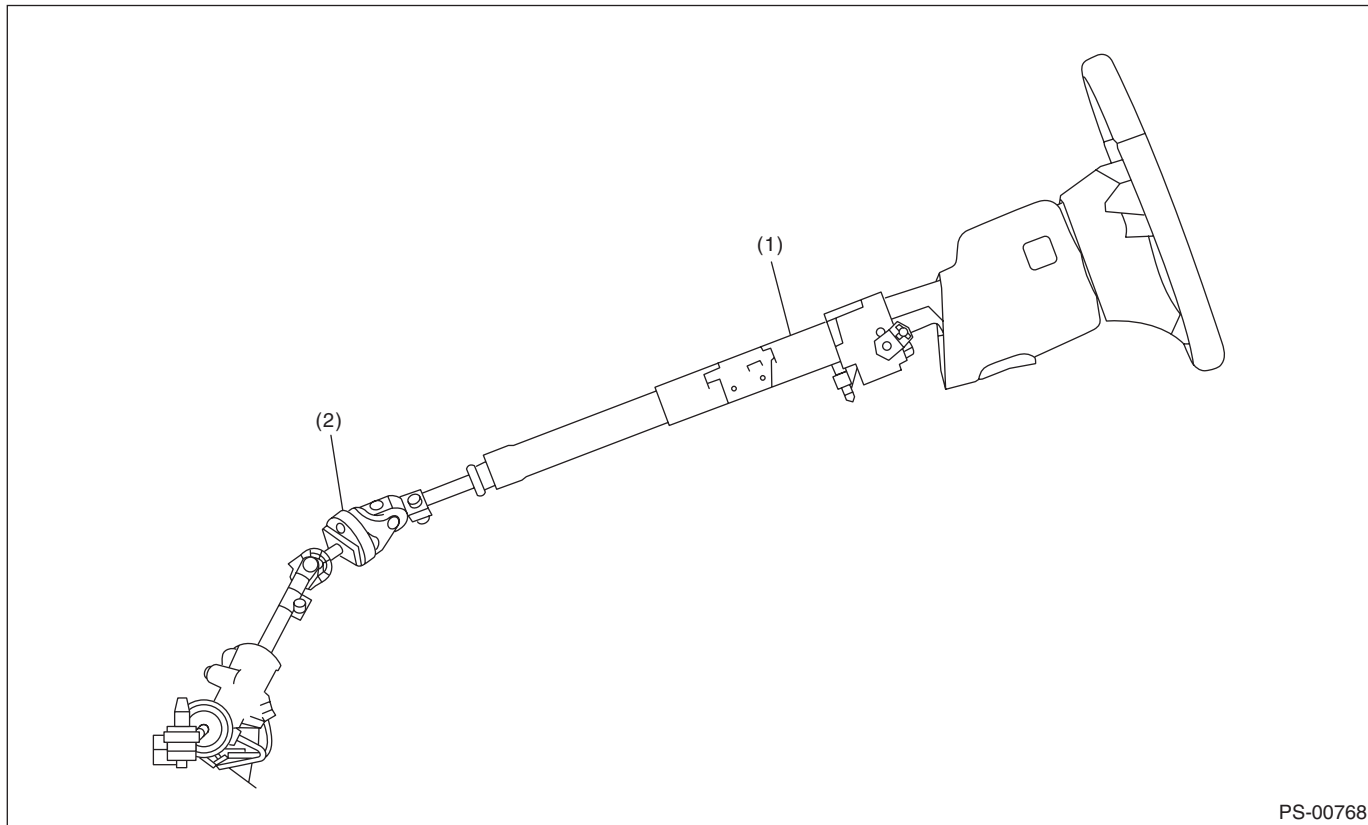

PS-00768

(1) Tilt steering column

(2) Universal joint

- 1) Remove the steering wheel. <Ref. to PS-14, REMOVAL, Steering Wheel.>
- 2) Remove the universal joint. <Ref. to PS-15, REMOVAL, Universal Joint.>
- 3) Remove the instrument panel lower cover under.
- 4) Remove the instrument panel lower cover upper.
- 5) Remove all connectors from the steering column.
- 6) Remove the two bolts under instrument panel securing the steering column.

- 7) Pull out the steering shaft assembly from the hole on toe board.

CAUTION:

- Be sure to remove the universal joint before removing steering shaft assembly installing bolts when removing steering shaft assembly or when lowering it for servicing other parts.
- Do not loosen the tilt lever when the steering column is not secured to the vehicle.

B: INSTALLATION

- 1) Install the grommet to the toe board.

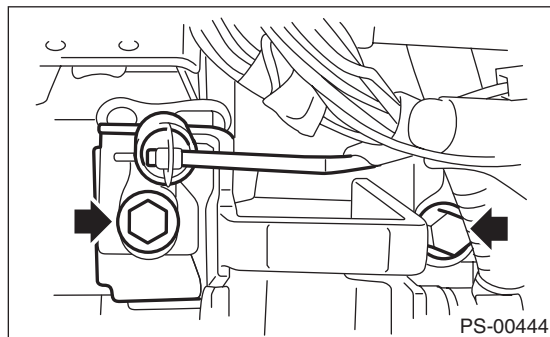

PS-00444

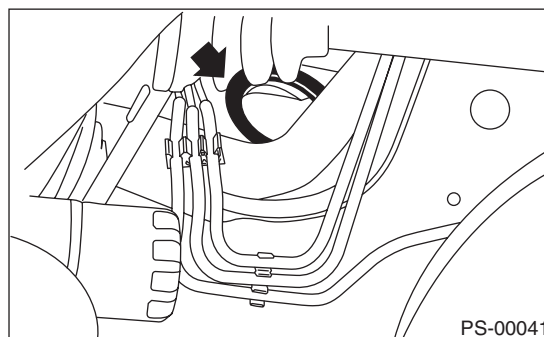

PS-00041

- 2) Insert the end of the steering shaft into the toe board grommet.

Tilt Steering Column

POWER ASSISTED SYSTEM (POWER STEERING)

3) With the tilt lever secured, tighten the steering shaft mounting bolts under instrument panel.

Tightening torque:

25 N·m (2.5 kgf·m, 18.1 ft-lb)

4) Connect all the connectors under the instrument panel.

5) Connect the airbag system connector at the harness spool.

NOTE:

Make sure to apply double lock.

6) Install the instrument panel lower cover with tilt lever held in the lowered position.

7) Install the universal joint. <Ref. to PS-15, INSTALLATION, Universal Joint.>

8) Align the center position of the roll connector. <Ref. to AB-26, ADJUSTMENT, Roll Connector.>

9) Install the steering wheel. <Ref. to PS-14, INSTALLATION, Steering Wheel.>

CAUTION:

Insert the roll connector guide pin into the guide hole on lower end of steering wheel surface to prevent damage.

C: DISASSEMBLY

Remove the two screws securing the upper steering column covers, and the two screws securing the combination switch, and then remove related parts.

D: ASSEMBLY

Insert the combination switch to the upper column shaft, and install the upper column cover. Then route the ignition key harness and combination switch harness between the column cover mounting bosses.

Tightening torque:

1.2 N·m (0.12 kgf·m, 0.9 ft-lb)

CAUTION:

Do not overtorque the screw.

E: INSPECTION

1. BASIC INSPECTION

Measure the overall length of steering column. If not within specification, replace it.

Overall length L:

Standard value

Except for the OUTBACK model

833.6^{+1.3 mm}_{-0.3 mm} (32.82^{+0.051 in}_{-0.020 in})

OUTBACK model

825.4^{+1.3 mm}_{-0.3 mm} (32.50^{+0.051 in}_{-0.020 in})

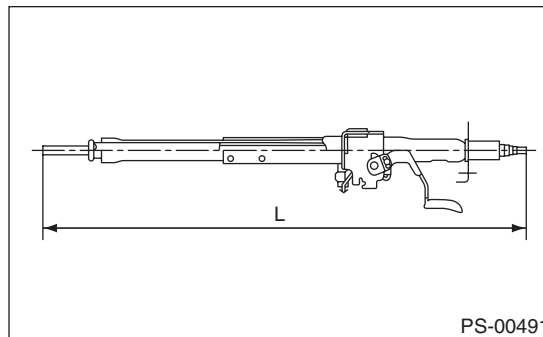

2. INSPECTION OF AIRBAG SYSTEM

WARNING:

Refer to “Airbag System” for airbag inspection procedure. <Ref. to AB-6, CAUTION, General Description.>