

# Pipe Assembly

POWER ASSISTED SYSTEM (POWER STEERING)

## 6. Pipe Assembly

### A: REMOVAL

- 1) Disconnect the ground cable from battery.
- 2) Lift-up the vehicle, and then remove the front crossmember support plate and jack-up plate.

- Large type

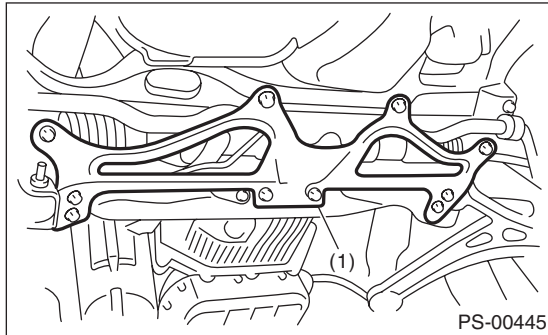

(1) Front crossmember support plate

- Small type

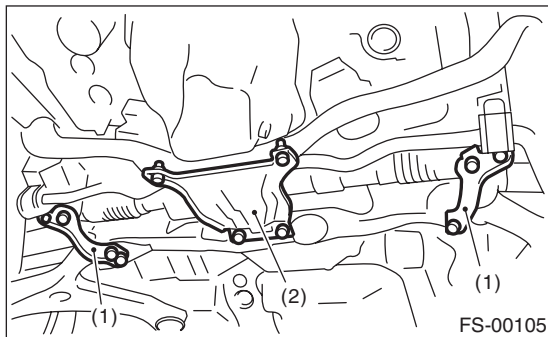

(1) Crossmember support plate  
(2) Jack-up plate

- 3) Remove the one pipe joint at the center of the gearbox, and connect the vinyl hose to the pipe and the joint. Discharge the fluid by turning the steering wheel fully clockwise and counterclockwise. Discharge the fluid similarly from other pipes.

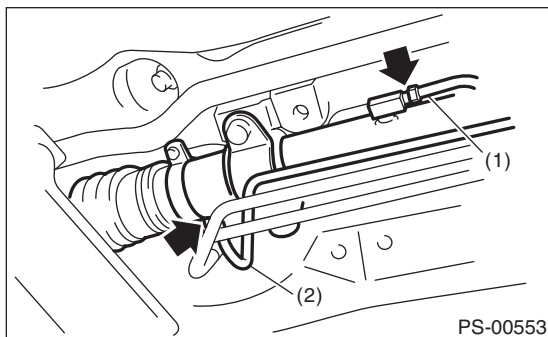

(1) Pipe A  
(2) Pipe B

- 4) Remove the clamp E from return hose and pressure hose.

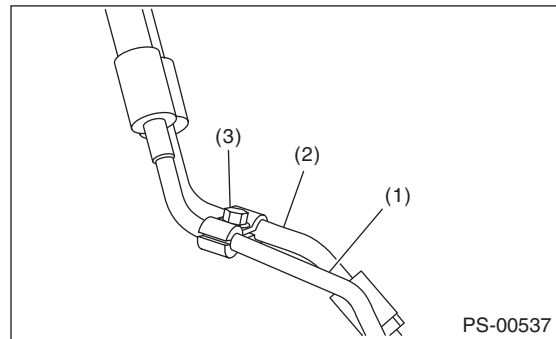

(1) Return hose  
(2) Pressure hose  
(3) Clamp E

- 5) Disconnect the pipe D from return hose and pipe C from pressure hose.

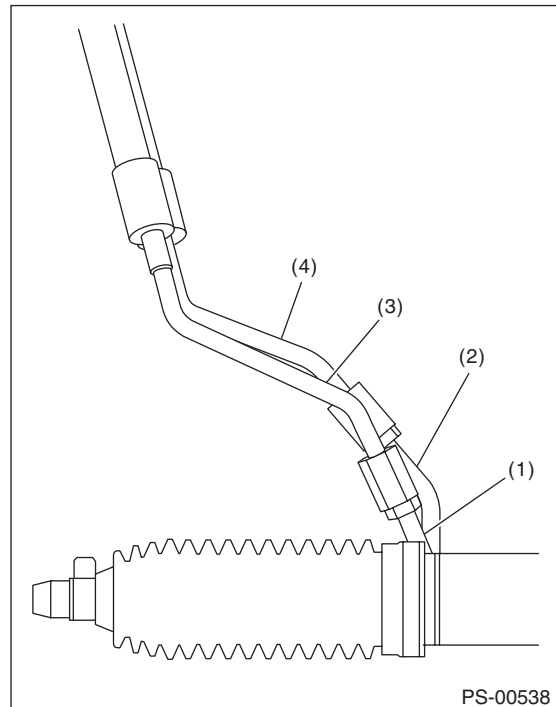

(1) Pipe C  
(2) Pipe D  
(3) Pressure hose  
(4) Return hose

- 6) Remove the air intake duct. <Ref. to IN(H4DOTC)-9, REMOVAL, Air Intake Duct.>  
<Ref. to IN(H4SO)-8, REMOVAL, Air Intake Duct.>

# Pipe Assembly

## POWER ASSISTED SYSTEM (POWER STEERING)

7) Disconnect the suction hose and pressure hose from oil pump.

• H6 model

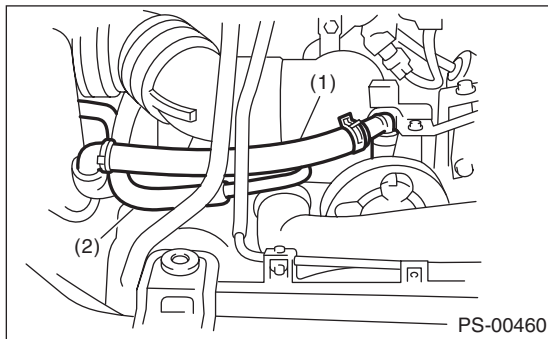

- (1) Suction hose
- (2) Pressure hose

8) Disconnect the suction hose and return hose from the reservoir tank. Remove the oil cooler from the oil cooler bracket.

• H4 model

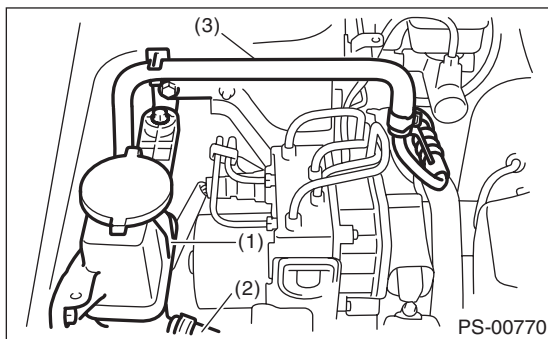

- (1) Reservoir tank
- (2) Suction hose
- (3) Return hose

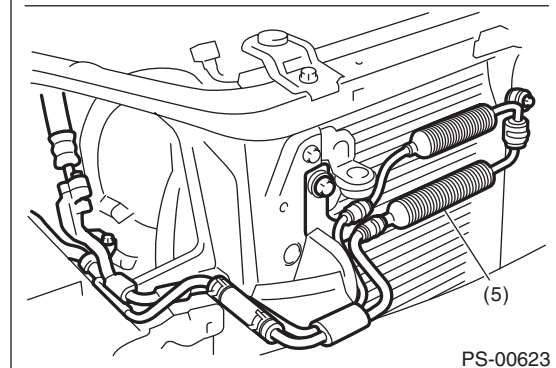
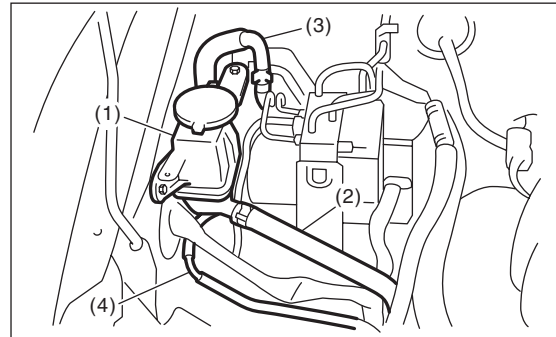

- (1) Reservoir tank
- (2) Suction hose
- (3) Return hose
- (4) Oil cooler pipe
- (5) Oil cooler

9) Remove the hose bracket and take out the hose assembly from vehicle.

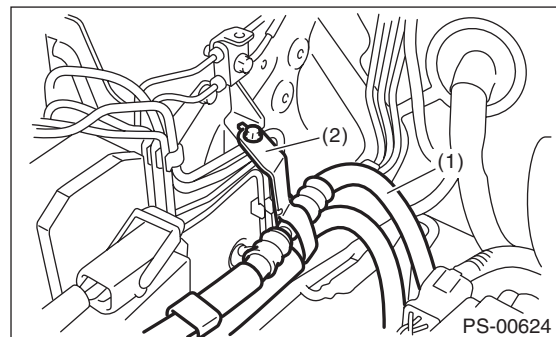

- (1) Hose ASSY
- (2) Hose bracket

# Pipe Assembly

## POWER ASSISTED SYSTEM (POWER STEERING)

### B: INSTALLATION

1) Temporarily tighten the hose bracket bolt.

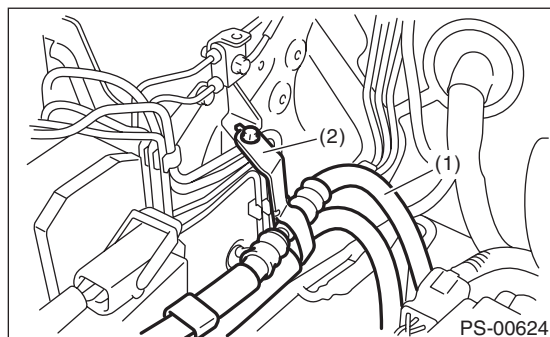

- (1) Hose ASSY
- (2) Hose bracket

2) Install the plastic clip to the pressure hose and suction hose.

#### CAUTION:

**Align the installation position of the plastic clip with the protector edge of the suction hose.**

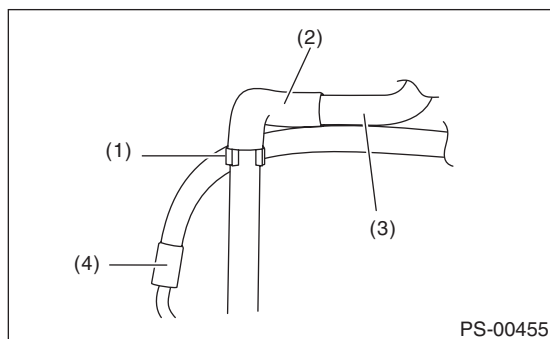

- (1) Plastic clip
- (2) Protector
- (3) Suction hose
- (4) Pressure hose

3) Connect the suction hose and return hose to the reservoir tank. Install the oil cooler to the oil cooler bracket.

#### CAUTION:

**Firmly insert the plastic clip of return hose to the bracket.**

- H4 model

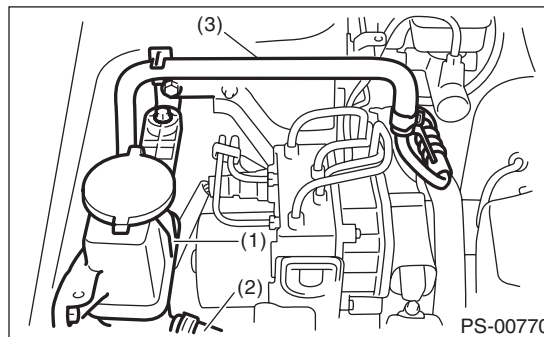

- (1) Reservoir tank
- (2) Suction hose
- (3) Return hose

- H6 model

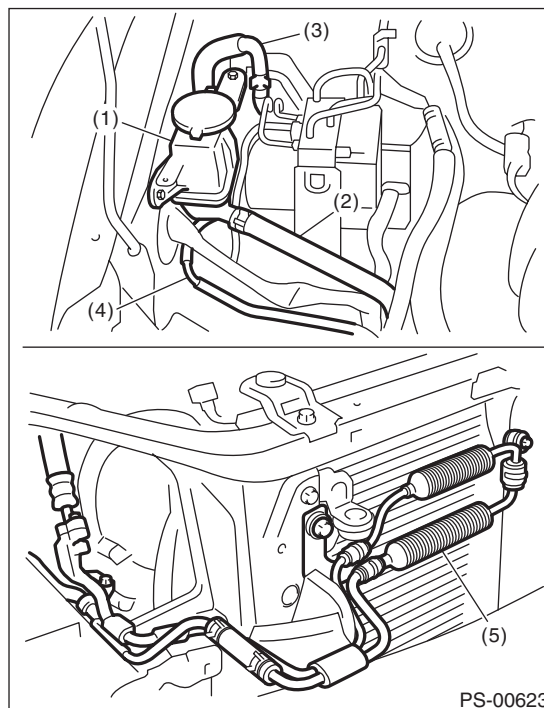

- (1) Reservoir tank
- (2) Suction hose
- (3) Return hose
- (4) Oil cooler pipe
- (5) Oil cooler

# Pipe Assembly

## POWER ASSISTED SYSTEM (POWER STEERING)

4) Connect the suction hose and pressure hose to the oil pump. Tighten the eye bolt of pressure hose.

**Tightening torque:**

**40 N·m (4.1 kgf·m, 29.5 ft·lb)**

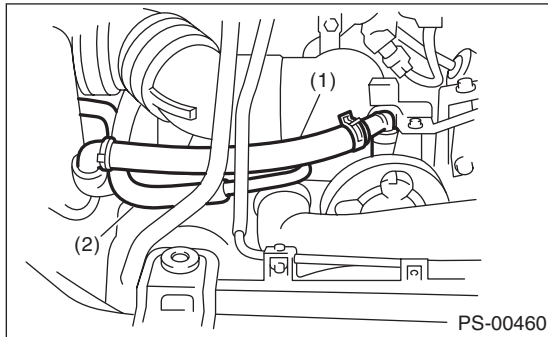

- (1) Suction hose
- (2) Pressure hose

5) Temporarily connect pressure hose and pipe C, and the return hose and pipe D. Place clamp E in the position shown in the figure, and tighten the bolt temporarily.

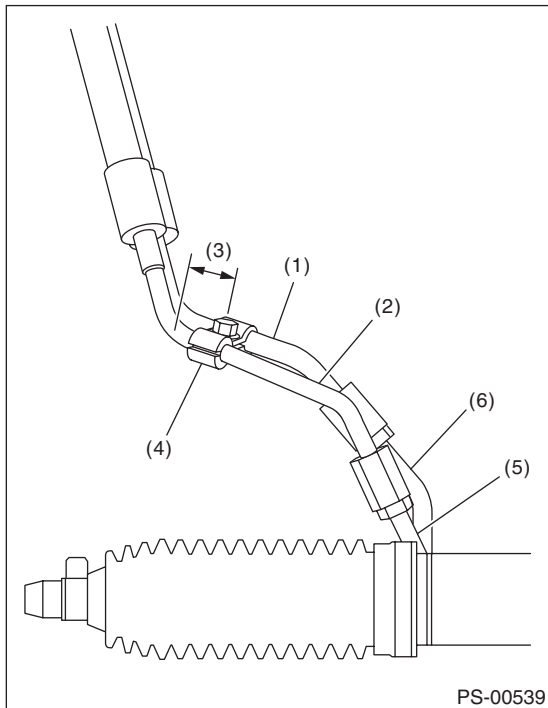

- (1) Return hose
- (2) Pressure hose
- (3) Approx. 18 mm (0.71 in)
- (4) Clamp E
- (5) Pipe C
- (6) Pipe D

6) Tighten clamp E.

**Tightening torque:**

**7.4 N·m (0.75 kgf·m, 5.4 ft·lb)**

7) Tighten the pressure hose and pipe C, and the return hose and pipe D.

**Tightening torque:**

**15 N·m (1.5 kgf·m, 10.8 ft·lb)**

8) Connect pipes A and B to the four pipe joints of the gearbox.

**Tightening torque:**

**Refer to "COMPONENT" of "General Description". <Ref. to PS-4, POWER ASSISTED SYSTEM, COMPONENT, General Description.>**

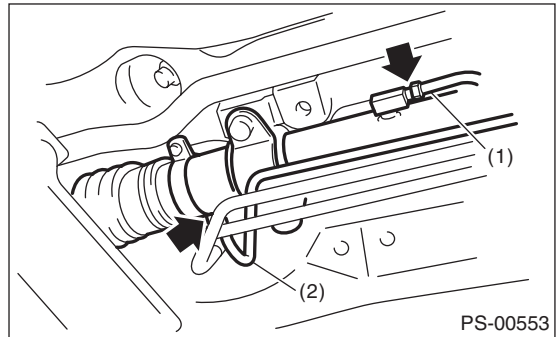

- (1) Pipe A
- (2) Pipe B

9) Install the front crossmember support plate and jack-up plate.

10) Lower the vehicle.

11) Tighten the bolts which hold the hose bracket.

**Tightening torque:**

**10 N·m (1.02 kgf·m, 7.4 ft·lb)**

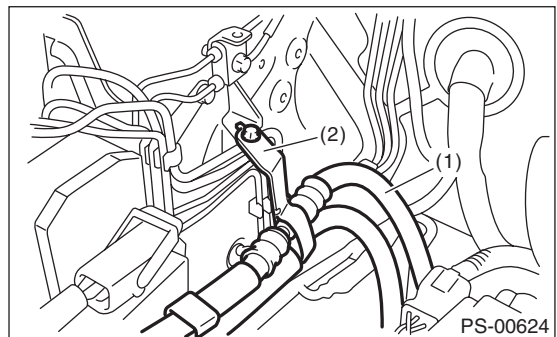

- (1) Hose ASSY
- (2) Hose bracket

12) Install the air intake duct. <Ref. to IN(H4DOTC)-9, INSTALLATION, Air Intake Duct.> <Ref. to IN(H4SO)-8, INSTALLATION, Air Intake Duct.>

13) Connect the ground cable to battery.

14) Fill with the specified fluid.

**CAUTION:**

**Never start the engine before filling with fluid; otherwise the vane pump may become seized.**

# Pipe Assembly

POWER ASSISTED SYSTEM (POWER STEERING)

15) Finally, check the clearance between pipes or hoses as shown in the figure indicated in "General Diagnostic Table". <Ref. to PS-59, INSPECTION OF CLEARANCE, INSPECTION, General Diagnostic Table.>

## C: INSPECTION

Check all disassembled parts for wear, damage or other problems. Repair or replace the defective parts as necessary.

Part	Maintenance parts	Corrective action
Pipe	<ul style="list-style-type: none"> <li>• O-ring fitting surface damage</li> <li>• Nut damage</li> <li>• Pipe damage</li> </ul>	Replace with a new part.
Clamp	<ul style="list-style-type: none"> <li>• Loose clamps</li> </ul>	Replace with a new part.
Hose	<ul style="list-style-type: none"> <li>• Flare surface damage</li> <li>• Flare nut damage</li> <li>• Outer surface cracks</li> <li>• Outer surface wear</li> <li>• Clip damage</li> <li>• End coupling or adapter deformation</li> </ul>	Replace with a new part.

### CAUTION:

**Although the surface layer materials of rubber hoses have excellent weathering resistance, heat resistance and resistance for low temperature brittleness, they are likely to be damaged chemically by brake fluid, battery electrolyte, engine oil and automatic transmission fluid and their service lives are to be very shortened. Wipe off hoses immediately if any of these come into contact with the hoses. Since resistances for heat or low temperature brittleness are gradually declining according to time accumulation of hot or cold conditions for the hoses and their service lives are shortening accordingly, it is necessary to perform careful inspection frequently when the vehicle is used in hot weather areas, cold weather areas and a driving condition in which many steering operations are required in short time.**

**Continuous discharge of the relief valve for over 5 seconds will reduce the service lives of hoses, oil pump, fluid, etc., due to over heating.**

Trouble	Possible cause	Corrective action
Pressure hose burst	Excessive holding time of relief status	Instruct customers.
	Malfunction of the relief valve	Replace the oil pump.
	Poor cold characteristic of fluid	Replace fluid.
Disconnection of the return hose	Improper connection	Repair.
	Loosening of the clip	Retighten.
	Poor cold characteristic of fluid	Replace fluid.
Fluid slightly leaking out of hose	Wrong layout, tensioned	Replace the hose.
	Excessive play of engine due to deterioration of engine mounting rubber	Replace the parts if defective.
	Improper stop position of pitching stopper	Replace the parts if defective.
Crack on hose	Excessive holding time of relief status	Replace. Instruct customers.
	Excessive tightening torque for return hose clip	Replace.
	Power steering fluid, engine oil, electrolyte adhere on the hose surface	Replace. Be careful during service work.
	Too many uses in extremely cold weather	Replace. Instruct customers.

# Pipe Assembly

## POWER ASSISTED SYSTEM (POWER STEERING)

### NOTE:

There are conditions in which a fluid leak is diagnosed, but is not actually leaking. This is because the fluid spilt during the last maintenance was not completely wiped off. Be sure to wipe off spilt fluid thoroughly after maintenance.

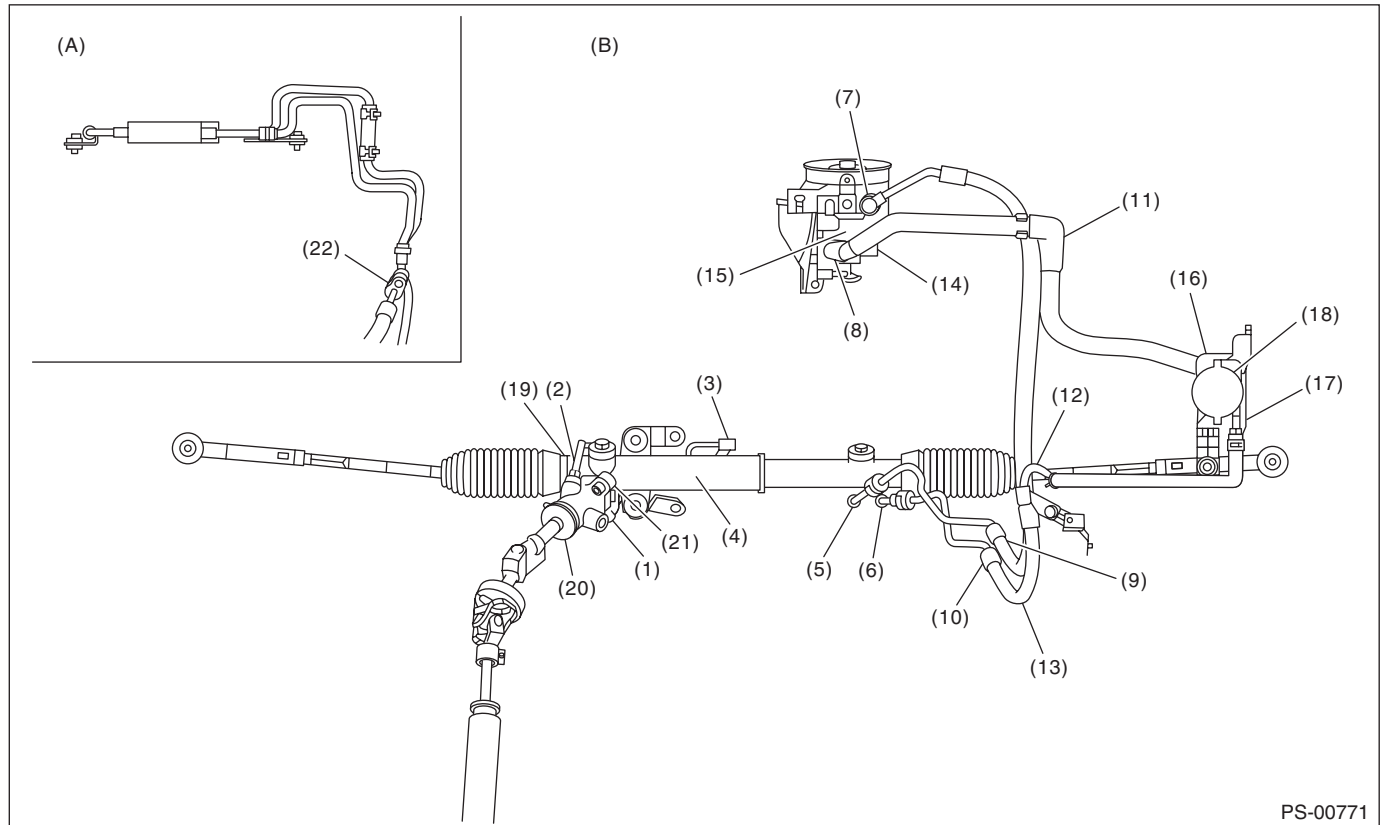

PS-00771

(A) H6 model

(B) H4 model

Fluid leaking area	Possible cause	Corrective action
Leakage from the connections of pipes and hoses, numbered (1) through (8) in the figure	Insufficient tightening of flare nut, adhesion of dirt, damage to flare or flare nut or eye bolt	Loosen and retighten. Replace if ineffective.
	Improper installation of hose or clamp	Retighten or replace the clamp.
	Damaged O-ring or gasket	Replace the O-ring, gasket pipe or hose with new part, if still no improvement, replace the gearbox as well.
Leakage from hose (9) through (13) in the figure	Crack or damage in hose	Replace with a new part.
	Crack or damage in hose hardware	Replace with a new part.
Leakage from surrounding of cast iron portion of oil pump, (14) and (15) in the figure	Damaged O-ring	Replace the oil pump.
	Damaged gasket	Replace the oil pump.
Leakage from oil tank, (16) and (17) in the figure	Crack in oil tank	Replace the oil tank.
Leakage from filler neck of (18)	Damaged cap packing	Replace the cap.
	Crack in root of filler neck	Replace the oil tank.
	Fluid level too high	Adjust the fluid level.
Leakage from power cylinder of gearbox area (19) in the figure	Damaged oil seal	Replace the oil seal.
Leakage from (20), (21) in the figure and control valve of gearbox	Damaged packing or oil seal	Replace the problem parts.
	Damage in control valve	Replace the control valve.
(22) Leakage from the joints between cooler pipe and hose.	Insufficient tightening of connecting portion.	Loosen and retighten.