

4. Rear Arm

A: REMOVAL

- 1) Lift up the vehicle, and then remove the rear wheels.
- 2) Remove the sub frame support arm.
<Ref. to RS-20, REMOVAL, Sub Frame Support Arm.>
- 3) Remove the bearing unit.
<Ref. to DS-19, REMOVAL, Rear Hub Unit Bearing.>
- 4) Hang the back plate from sub frame.

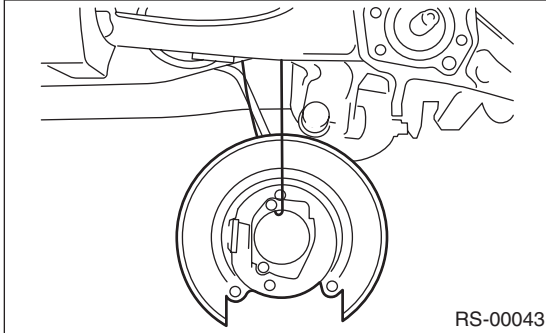

- 5) Remove the bolt which secures the parking brake cable clamp to the rear arm bracket.

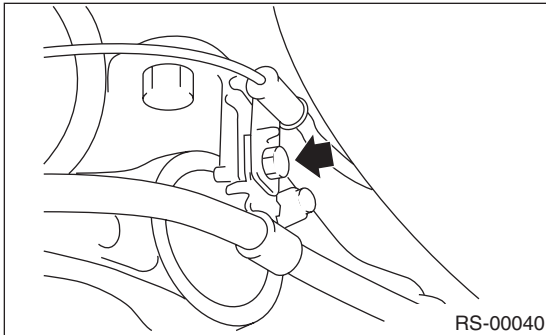

- 6) Remove the bolt which holds the brake hose bracket and ABS wheel speed sensor bracket to the rear arm.

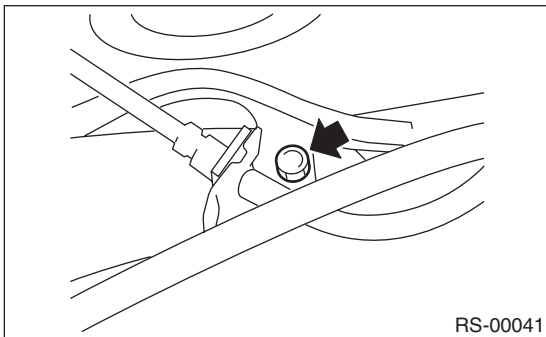

- 7) Remove the bolts which secure the brake hose bracket to the rear arm. Remove the bolts which secure the ABS wheel speed sensor to the rear arm.

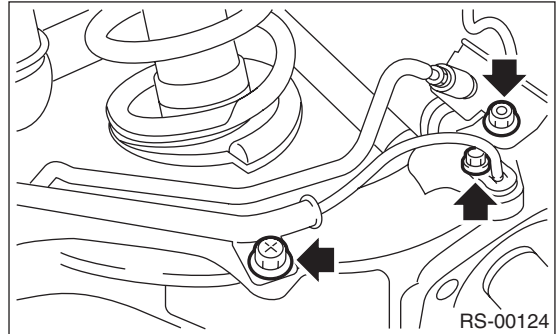

- 8) Remove the stabilizer link from the rear arm.

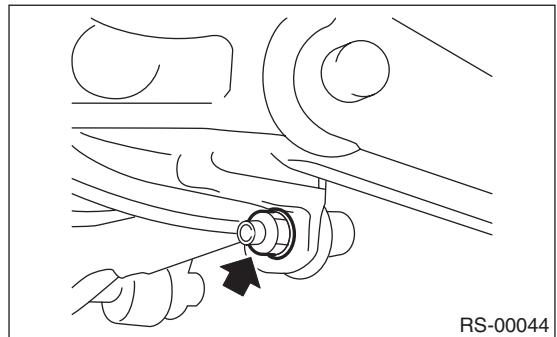

- 9) Remove the shock absorber from the rear arm.

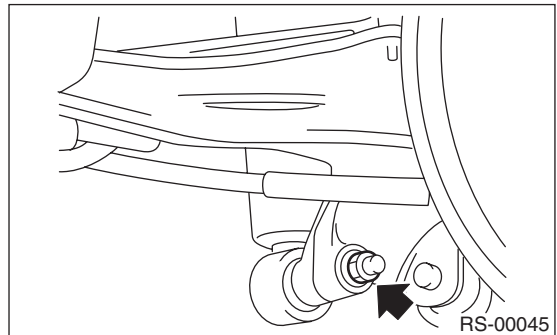

- 10) Support the rear arm horizontally using a transmission jack.

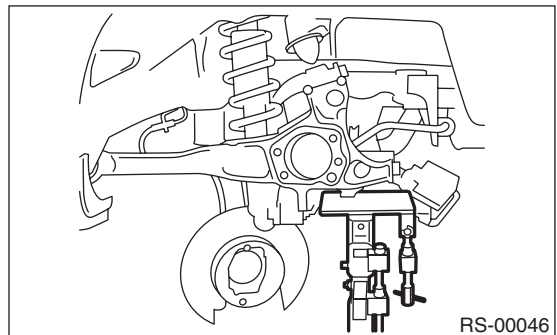

Rear Arm

REAR SUSPENSION

11) Remove the nuts which hold the rear arm to bracket. Remove the rear arm bracket.

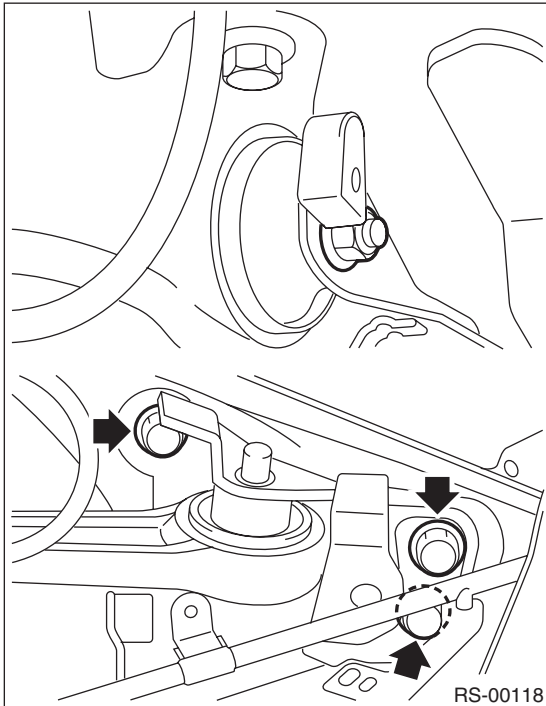

12) Loosen the nut which holds the front link to the rear arm.

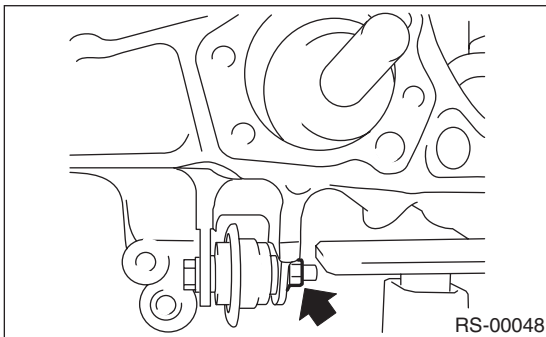

13) Loosen the nut which holds the rear link to the rear arm.

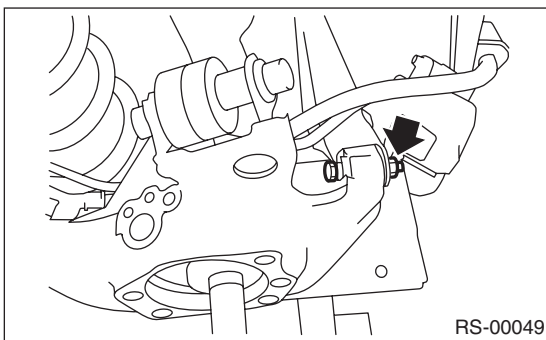

14) Loosen the nut which holds the upper link to the rear arm.

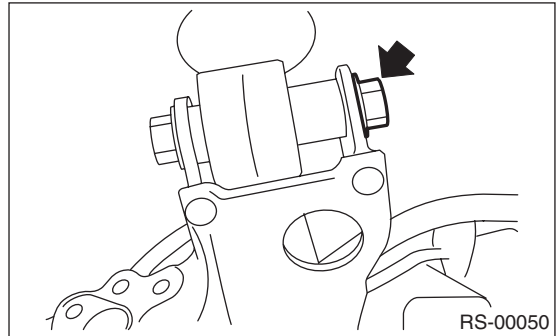

15) Remove the bolt which secures the rear arm to the link, and then remove the rear arm.

B: INSTALLATION

NOTE:

Use a new bolt and self-locking nut. For parts which are not reusable, refer to "COMPONENT". <Ref. to RS-3, REAR SUSPENSION, COMPONENT, General Description.>

- 1) Support the rear arm using a transmission jack.
- 2) Install the rear arm and temporarily tighten the bolts which hold the rear arm to the link.
- 3) Install the bearing unit.

<Ref. to DS-20, INSTALLATION, Rear Hub Unit Bearing.>

- 4) Install the bolts which secure the ABS wheel speed sensor to rear arm.
- 5) Install the bolts which secure the brake hose to the rear arm.
- 6) Install bolts which secure the parking brake cable clamp to the rear arm bracket.
- 7) Set the vehicle equipped jack upside down, between the rear link and sub frame. Align the location of the jack, and with the rear shock absorber and rear arm attachment locations matched, temporarily tighten the bolt and nut.

CAUTION:

Protect the rear link and sub frame from being damaged by putting a waste cloth between the contact surface with the jack.

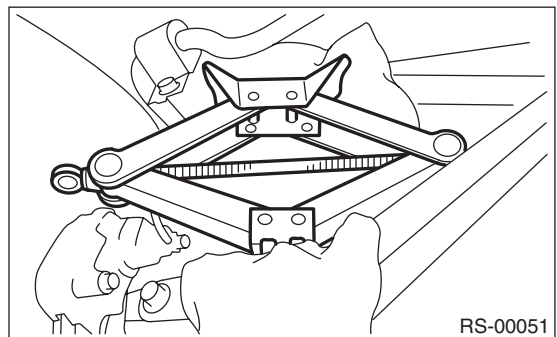

8) Support the rear arm horizontally using a transmission jack.

9) Tighten the nuts and bolts which hold the rear arm, front link, rear link, upper link and shock absorber.

NOTE:

Always tighten the stabilizer bushing in the state where the vehicle is at curb weight and the wheels are in full contact with the ground.

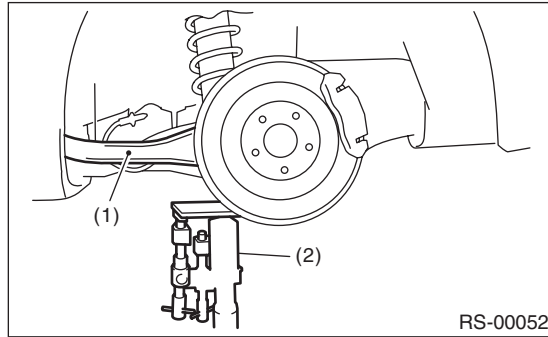

- (1) Rear arm
- (2) Transmission jack

10) Install the sub frame support arm.

NOTE:

Inspect the wheel alignment and adjust it if necessary.

Tightening torque:

Refer to "COMPONENT" of "General Description" for the tightening torque. <Ref. to RS-3, REAR SUSPENSION, COMPONENT, General Description.>

C: DISASSEMBLY

1. FRONT BUSHING

- 1) Set the ST A with the larger side of its inner diameter turned upward.
- 2) Set the rear arm with the protruding side of bushing turned upward.
- 3) Place the ST B on bushing, and push the bushing out.

ST-A 20099AE020INSTALLER & REMOVER SET

ST-B 20099AE020INSTALLER & REMOVER SET

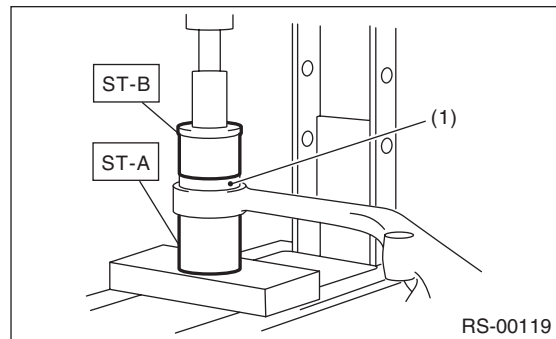

- (1) Bushing

2. REAR BUSHING

Using the ST C and bearing puller, press the rear bushing out.

ST-C 20099AE040INSTALLER & REMOVER SET

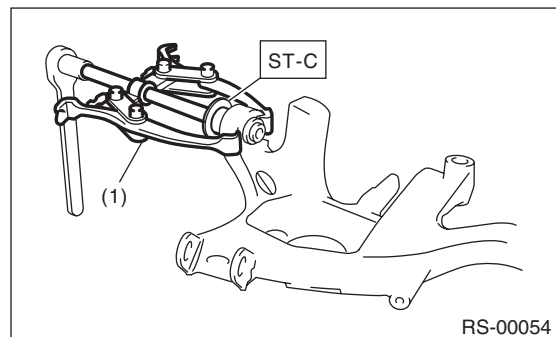

- (1) Bearing puller

Rear Arm

REAR SUSPENSION

D: ASSEMBLY

1. FRONT BUSHING

- 1) Set the ST A with the larger side of its inner diameter turned upward.
- 2) Set the rear arm with the vehicle inner side of arm turned downward.
- 3) Place the bushing on rear arm as shown in the figure.
- 4) Place the ST B on the bushing, and press-fit until each edge surface of bushing and rear arm is aligned.

ST-A 20099AE020INSTALLER & REMOVER SET

ST-B 20099AE020INSTALLER & REMOVER SET

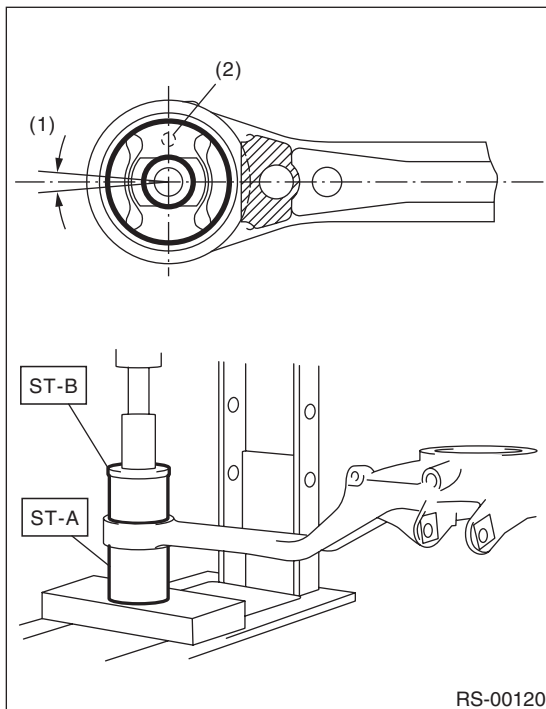

- (1) $0 \pm 5^\circ$
- (2) Identification paint: Assemble with the identification paint side facing the arm inner side.

2. REAR BUSHING

- 1) Insert the bushing into the bore of ST D.
- 2) Set the ST C, ST D and bearing puller in the specified positions as shown in the figure, and then press-fit the bush until the outer end of bush and rear end of rear arm is flat.

ST-C 20099AE040INSTALLER & REMOVER SET

ST-D 20099AE040INSTALLER & REMOVER SET

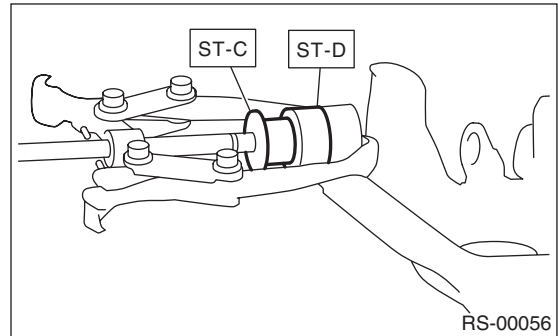

E: INSPECTION

Check the rear arm for bending, corrosion or damage.