

11.Roll Connector

A: REMOVAL

- 1) Turn the ignition switch to OFF.
- 2) Disconnect the ground cable from battery and wait for at least 20 seconds before starting work.
- 3) Remove the driver's airbag module. <Ref. to AB-17, REMOVAL, Driver's Airbag Module.>
- 4) Remove the steering wheel. <Ref. to PS-14, REMOVAL, Steering Wheel.>
- 5) Remove the steering column cover.
- 6) Remove the screws, and then remove the roll connector.

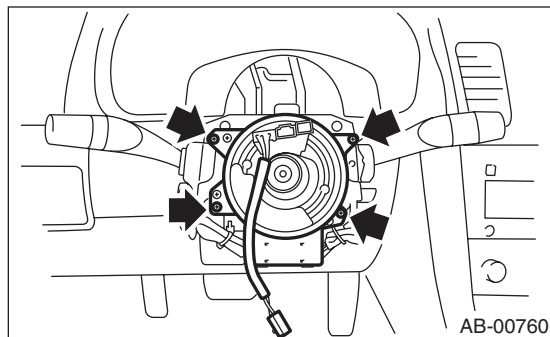

B: INSTALLATION

- 1) Install in the reverse order of removal.
- 2) Before installing steering wheel, be sure to adjust the direction of roll connector with steering. <Ref. to AB-26, ADJUSTMENT, Roll Connector.>

C: INSPECTION

Check for the following, and replace the damaged parts with new parts.

Combination switch and roll connector are cracked or deformed.

D: ADJUSTMENT

- 1) Check that front wheels are positioned in straight ahead direction.
- 2) Turn the roll connector pin (A) clockwise until it stops.
- 3) Turn the roll connector pins (A) approx. 3.25 turns until "▲" marks are aligned.

