

# Inspection Locations After a Collision

## AIRBAG SYSTEM

### 3. Inspection Locations After a Collision

#### A: REPLACEMENT

Replace the following parts when the airbag is deployed.

##### 1. FRONT COLLISION

- 1) Driver's airbag module
- 2) Passenger's airbag module
- 3) Driver's seat belt (Pretensioner)
- 4) Passenger's seat belt (Pretensioner)
- 5) Airbag control module
- 6) Front sub sensor (L/R)
- 7) Roll connector
- 8) Instrument panel (for integrating with passenger's airbag module)
- 9) Passenger's side seat cushion pad and frame assembly

##### 2. SIDE COLLISION

- 1) Airbag control module
- 2) Side airbag module (operating side seat backrest)
- 3) Side airbag sensor (Operating side)
- 4) Curtain airbag module (operating side)
- 5) Curtain airbag sensor (operating side)

##### 3. INSPECTION OF OTHER PARTS

Check for the following parts, and replace the damaged parts with new parts.

- 1) Steering wheel and steering shaft  
Check the steering shaft for mounting conditions and deflection of front and rear, upward and downward directions, and deflection of front and rear direction with tilt lever released. (After a collision, absorbing part of steering shaft may have been operated.)
- 2) Check the connectors of airbag module, pretensioner, etc. for damage, and also check each harness for pinch and connector damage. Replace the harness as a unit if damage is found.
- 3) Check the seat cushion frame, backrest, seat rail and headrest for deformation, distortion, crack, and installing condition and play.
- 4) For the passenger's seat, replace the seat cushion pad and frame assembly with a new part if the seat cushion pad and frame assembly is deformed or cracked.
- 5) If there are tears or loosening in the passenger side seat cushion cover, it may interfere with the proper operation of the passenger detection system. Replace with a new cushion cover.

6) Be sure to perform the system calibration for the occupant detection system after removing or replacing the passenger seat cushion cover. Failure to do so may cause improper operation of the occupant detection system. <Ref. to OD(diag)-17, SYSTEM CALIBRATION (REZEROING), OPERATION, Subaru Select Monitor.>

7) Use the Subaru Select Monitor to check whether the driver's seat position sensor and the driver's and the front left/right seat belt buckle switches are operating normally.

#### B: INSPECTION

If the vehicle is involved in a collision, even if it is a slight collision, be sure to check the following systems.

##### 1. DRIVER'S AIRBAG MODULE

- 1) Check for the following, and replace the damaged parts with new parts.
  - Airbag module is cracked or deformed.
  - Harness and/or connector is cracked, deformed or open. Harness wire is exposed.
  - The module surface is fouled with grease, oil, water or cleaning solvent.
- 2) When installing a new driver's airbag module, check for the following, and replace the damaged parts with new parts.
  - The steering wheel is in the way, making it difficult to install the airbag module.
  - The clearance between the driver's airbag module and steering wheel is not constant.
  - When steering wheel deformation in axial and vertical directions exceed limits.

##### **Specification:**

###### ***Axial deflection A***

***Less than 6 mm (0.24 in)***

###### ***Vertical deflection L***

***Less than 7 mm (0.28 in)***

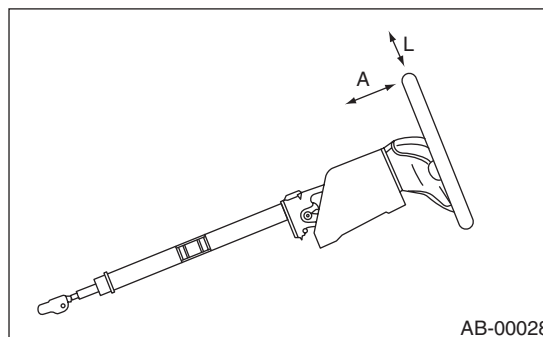

## 2. PASSENGER'S AIRBAG MODULE

Check for the following, and replace the damaged parts with new parts.

- Airbag module and instrument panel are cracked or deformed.
- Harness and/or connector is cracked, deformed or open. Harness wire is exposed.
- Mounting bracket is cracked or deformed.

## 3. SIDE AIRBAG MODULE

Check for the following, and replace the damaged parts with new parts.

- Front seat, airbag module and mounting bracket are damaged or deformed.
- Harness and/or connector is cracked, deformed or open. Harness wire is exposed.

## 4. CURTAIN AIRBAG MODULE

Check for the following, and replace the damaged parts with new parts.

- Airbag cover is scratched or torn.
- Harness and/or connector is cracked, deformed or open. Harness wire is exposed.
- Mounting bracket and securing clip are cracked or deformed.

## 5. AIRBAG CONTROL MODULE

Check for the following, and replace the damaged parts with new parts.

- Control module is cracked or deformed.
- Mounting bracket is cracked or deformed.
- Connector is scratched, cracked or deformed.
- Airbag is deployed.
- Side airbag is deployed.
- Curtain airbag is deployed.

## 6. FRONT SUB SENSOR

If the section of vehicle as shown in the figure is damaged, check the following items and replace the damaged parts with new parts.

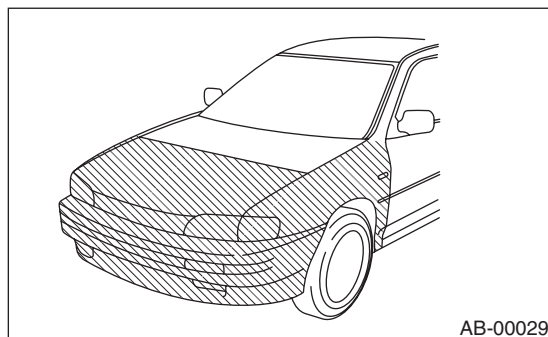

- Front sub sensor is cracked or deformed.
- Mounting bracket is cracked or deformed.
- Connector is scratched, cracked or deformed.
- Airbag is deployed.

## 7. SIDE AIRBAG SENSOR AND CURTAIN AIRBAG SENSOR

If the section of vehicle as shown in the figure is damaged, check the following items and replace the damaged parts with new parts.

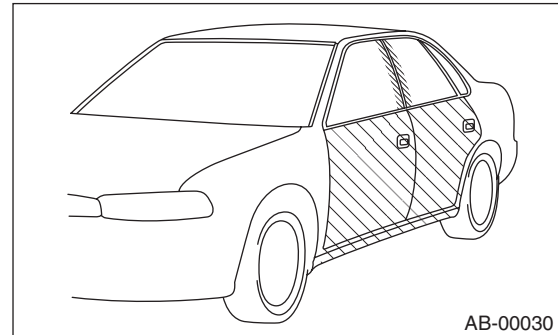

- Side airbag sensor and curtain airbag sensor are cracked or deformed.
- Mounting bracket is cracked or deformed.
- Connector is scratched, cracked or deformed.
- Side airbag or curtain airbag is deployed. (operating side)

## 8. ROLL CONNECTOR

Check for the following, and replace the damaged parts with new parts.

Combination switch or steering roll connector is cracked or deformed.

## 9. STEERING SHAFT

Check for the following, and replace the damaged parts with new parts.

Overall length of steering column should be within specification.

**Specification:**

**Overall length L**

**Excluding OUTBACK model**

$833.6^{+1.3}_{-0.3}$  mm (32.82<sup>+0.051</sup><sub>-0.012</sub> in)

**OUTBACK model**

$825.4^{+1.3}_{-0.3}$  mm (32.50<sup>+0.051</sup><sub>-0.012</sub> in)

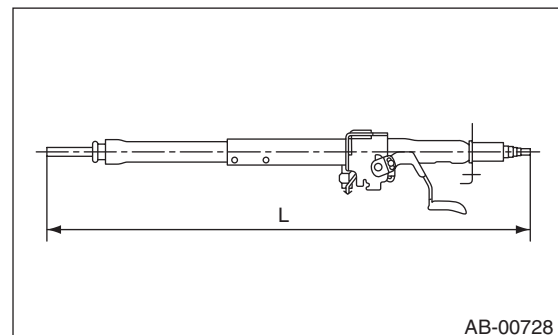

# Inspection Locations After a Collision

## AIRBAG SYSTEM

---

### 10. DRIVER'S SEAT

Check for the following, and replace the damaged parts with new parts.

- Seat belt buckle or seat position sensor body/ bracket is cracked or deformed.
- Harness and/or connector is cracked, deformed or open. Harness wire is exposed.

### 11. PASSENGER'S SEAT

1) Check for the following, and replace the damaged parts with new parts.

- Seat belt buckle body, bracket or connector is scratched, cracked or deformed.
- Backrest frame for crack or deformation
- Headrest for deformation or play
- If the seat cushion cover and seat back cover is scratched or coming loose, replace with a new cover and readjust the system. <Ref. to OD(diag)-17, SYSTEM CALIBRATION (REZEROING), OPERATION, Subaru Select Monitor.>

#### **CAUTION:**

**If any of the following applies, replace the seat cushion pad and frame assembly. Do not disassemble.**

- **Cracks or deformation found in the seat cushion frame or seat cushion pad.**
- **Scratches, cracks, or deformation found on the passenger detection system pressure sensor hoses or passenger detection control module, or attachment brackets of the control module.**
- **Harness and/or connector is cracked, deformed or open. Harness wire is exposed.**

2) After checking the installing condition of passenger's seat, perform the system calibration of occupant detection system. <Ref. to OD(diag)-17, SYSTEM CALIBRATION (REZEROING), OPERATION, Subaru Select Monitor.>

### 12. BELT TENSION SENSOR

Check for the following, and replace the damaged parts with new parts.

- Belt tension sensor is scratched, cracked, or deformed.
- Harness and/or connector is cracked, deformed or open. Harness wire is exposed.