

## 6. Side Airbag Module

### A: REMOVAL

#### CAUTION:

Refer to “CAUTION” of “General Description” before handling the airbag module. <Ref. to AB-6, CAUTION, General Description.>

#### NOTE:

Remove the passenger’s side by referring to driver’s side.

- 1) Turn the ignition switch to OFF.
- 2) Disconnect the ground cable from battery and wait for at least 20 seconds before starting work.
- 3) Remove the front seats. <Ref. to SE-9, REMOVAL, Front Seat.>
- 4) Disconnect the connector from the back side of seat cushion assembly, then remove the side airbag harness.
- 5) Remove the backrest cover. <Ref. to SE-9, DISASSEMBLY, Front Seat.>
- 6) Remove the nuts, and remove the side airbag module assembly from the back rest frame assembly.

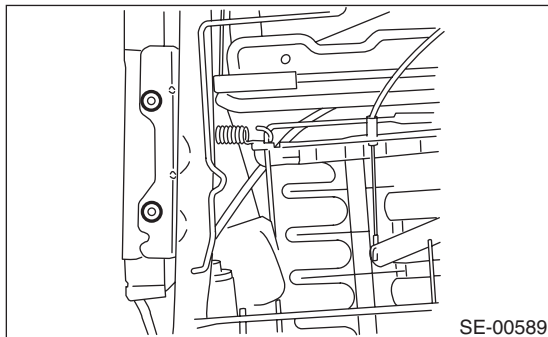

### B: INSTALLATION

#### CAUTION:

- Refer to “CAUTION” of “General Description” before handling the airbag module. <Ref. to AB-6, CAUTION, General Description.>
- Be sure to perform the system calibration for occupant detection system after passenger’s seat installation. <Ref. to OD(diag)-17, SYSTEM CALIBRATION (REZEROING), OPERATION, Subaru Select Monitor.>

- 1) Make sure that there is no foreign matter on side airbag module.
- 2) Install the side airbag module (A) to backrest frame assembly.

#### CAUTION:

**When attaching the side airbag module assembly, make sure to sandwich the seat backrest cover between the seat backrest side bracket and side airbag module.**

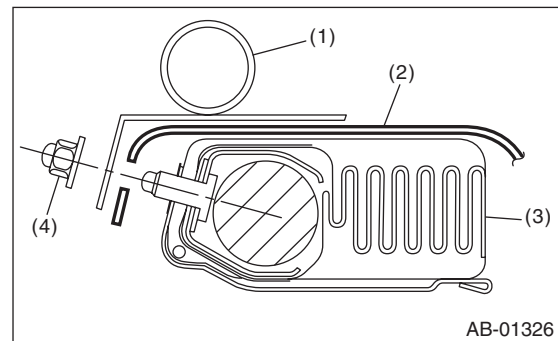

- (1) Backrest frame assembly
- (2) Backrest cover
- (3) Side airbag module assembly
- (4) Hexagon cap nut

#### **Tightening torque:**

**6.0 N·m (0.61 kgf·m, 4.4 ft·lb)**

- 3) Install the backrest cover. <Ref. to SE-15, ASSEMBLY, Front Seat.>
- 4) Draw the side airbag harness around the back side of seat cushion assembly.
- 5) Recline the seat or slide it backward and forward, and check there is no contact between the seat backrest assembly, cushion cover assembly and side airbag harness.

### C: INSPECTION

#### CAUTION:

Refer to “CAUTION” of “General Description” before handling the airbag module. <Ref. to AB-6, CAUTION, General Description.>

Check for the following, and replace the damaged parts with new parts. <Ref. to AB-15, SIDE AIRBAG MODULE, INSPECTION, Inspection Locations After a Collision.>

1) With side collision (when side airbag is deployed)

- Side airbag module assembly
- Backrest pad assembly
- Backrest frame assembly
- Backrest cover assembly

2) When damage is found by visual check

- Headrest assembly
- Bushing
- Slide rail OUT (Driver's side)
- Slide rail IN (Driver's side)
- Seat cushion pad and frame ASSY
- Seat hinge cover
- Seat lifter lever
- Reclining lever
- Side airbag harness and connector on body side

3) With side collision (when side airbag is not deployed)

Check the seat and airbag module visually, and then replace them with new parts if damaged or cracked.

Specially inspect the damage of airbag module body, mounting bracket and harness connector.

4) Without side collision (dirt and damage of cover)

Replace the corresponding part with a new part.