

7. Subaru Select Monitor

A: OPERATION

1. READ DIAGNOSTIC TROUBLE CODE (DTC)

When malfunction of airbag system occurs, the DTC stored in airbag control module will be read out.

1) Prepare the Subaru Select Monitor kit. <Ref. to AB(diag)-8, SPECIAL TOOL, PREPARATION TOOL, General Description.>



2) Connect the diagnosis cable to Subaru Select Monitor.

3) Insert the cartridge to Subaru Select Monitor. <Ref. to AB(diag)-8, SPECIAL TOOL, PREPARATION TOOL, General Description.>

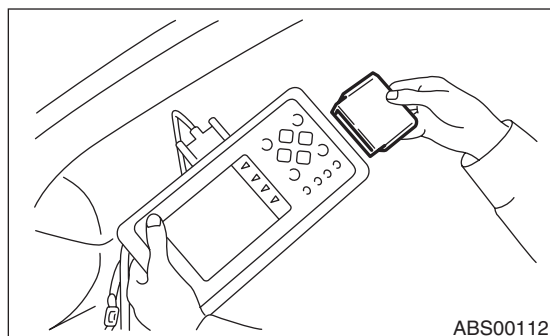

4) Connect the Subaru Select Monitor to the data link connector.

(1) Data link connector is located in the lower portion of instrument panel (on the driver's side).

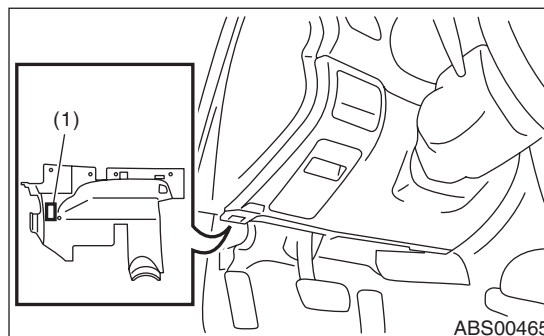

(1) Data link connector

(2) Connect the diagnosis cable to the data link connector.

CAUTION:

Do not connect the scan tools except for Subaru Select Monitor.

5) Turn the ignition switch to ON (engine OFF) and turn the Subaru Select Monitor switch to ON.

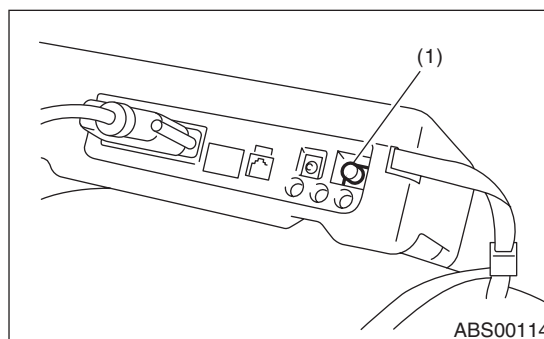

(1) Power switch

6) On the «Main Menu» display screen, select the {Each System Check} and press the [YES] key.

7) On the «System Selection Menu» display screen, select the {Airbag System} and press the [YES] key.

8) {Press the [YES] key after the {**MY AIRBAG SYSTEM} is displayed.

9) On the «Airbag System» screen, select the {DTC Display}, and then press the [YES] key.

NOTE:

- For details concerning operation procedures, refer to the "SUBARU SELECT MONITOR OPERATION MANUAL".

- For details concerning DTCs, refer to List of Diagnostic Trouble Code (DTC). <Ref. to AB(diag)-43, List of Diagnostic Trouble Code (DTC).>

Subaru Select Monitor

AIRBAG SYSTEM (DIAGNOSTICS)

2. DISPLAY OF STATUS INFORMATION

Check the operating condition of each sensor in the event of malfunction in the seat belt buckle switch and seat position sensor, or when the seat belt buckle switch and seat position sensor has been replaced.

- 1) On the «Main Menu» display screen, select the {Each System Check} and press the [YES] key.
- 2) On the «System Selection Menu» display screen, select the {Airbag System} and press the [YES] key.
- 3) On the «Airbag System» display screen, select the {Status Data} and press the [YES] key.

The following table is for support data.

Item	Display
Seat position sensor LH	Front position ^{*1} /Rear position ^{*2} /Other ^{*3} /Initial setting ^{*3} /— ^{*5}
Seat position sensor RH	— ^{*5}
Seat belt buckle switch LH	Belted ^{*6} /Unbelted ^{*7} /Other ^{*8} /Initial setting ^{*4} /— ^{*9}
Seat belt buckle switch RH	Belted ^{*6} /Unbelted ^{*7} /Other ^{*8} /Initial setting ^{*4} /— ^{*9}
Passenger's airbag control status	ON ^{*10} /OFF ^{*11} /Initial setting ^{*4}

*1: The seat position is forward.

*2: The seat position is rearward.

*3: Displayed when data other than before and behind the seat, such as the breakdown etc, is input.

*4: Displayed when it is initial.

*5: Seat position sensor not supported

*6: Seat belt fastened

*7: Seat belt not fastened

*8: Displayed when data other than belt fastened or not fastened, such as breakdowns is input.

*9: Seat belt buckle switch not supported

*10: Passenger's airbag operating state

*11: Passenger's airbag non-operating state

NOTE:

For details concerning operation procedures, refer to the “SUBARU SELECT MONITOR OPERATION MANUAL”.

3. CLEAR MEMORY MODE

Clear the DTC stored in the airbag control module after repairing the airbag system. (After the breakdown is recovered, the breakdown code for completed recoveries are read out when the next breakdown occurs if the memory clear work is not performed.)

- 1) On the «Main Menu» display screen, select the {Each System Check} and press the [YES] key.
- 2) On the «System Selection Menu» display screen, select the {Airbag System} and press the [YES] key.
- 3) On the {Airbag System} menu screen, select the {Clear Memory} and press the [YES] key.
- 4) When the “Clear Memory?” is shown on the screen, press the [YES] key.
- 5) When “Done” is displayed, turn the Subaru Select Monitor to OFF.

NOTE:

For details concerning operation procedure, refer to the “SUBARU SELECT MONITOR OPERATION MANUAL”.

B: INSPECTION

1. COMMUNICATION FOR INITIALIZING IMPOSSIBLE

DETECTING CONDITION:

Defective harness connector

TROUBLE SYMPTOM:

Communication is impossible between the airbag control module and the Subaru Select Monitor.

WIRING DIAGRAM:

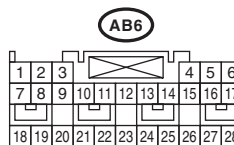
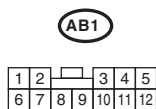
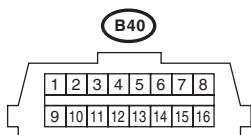
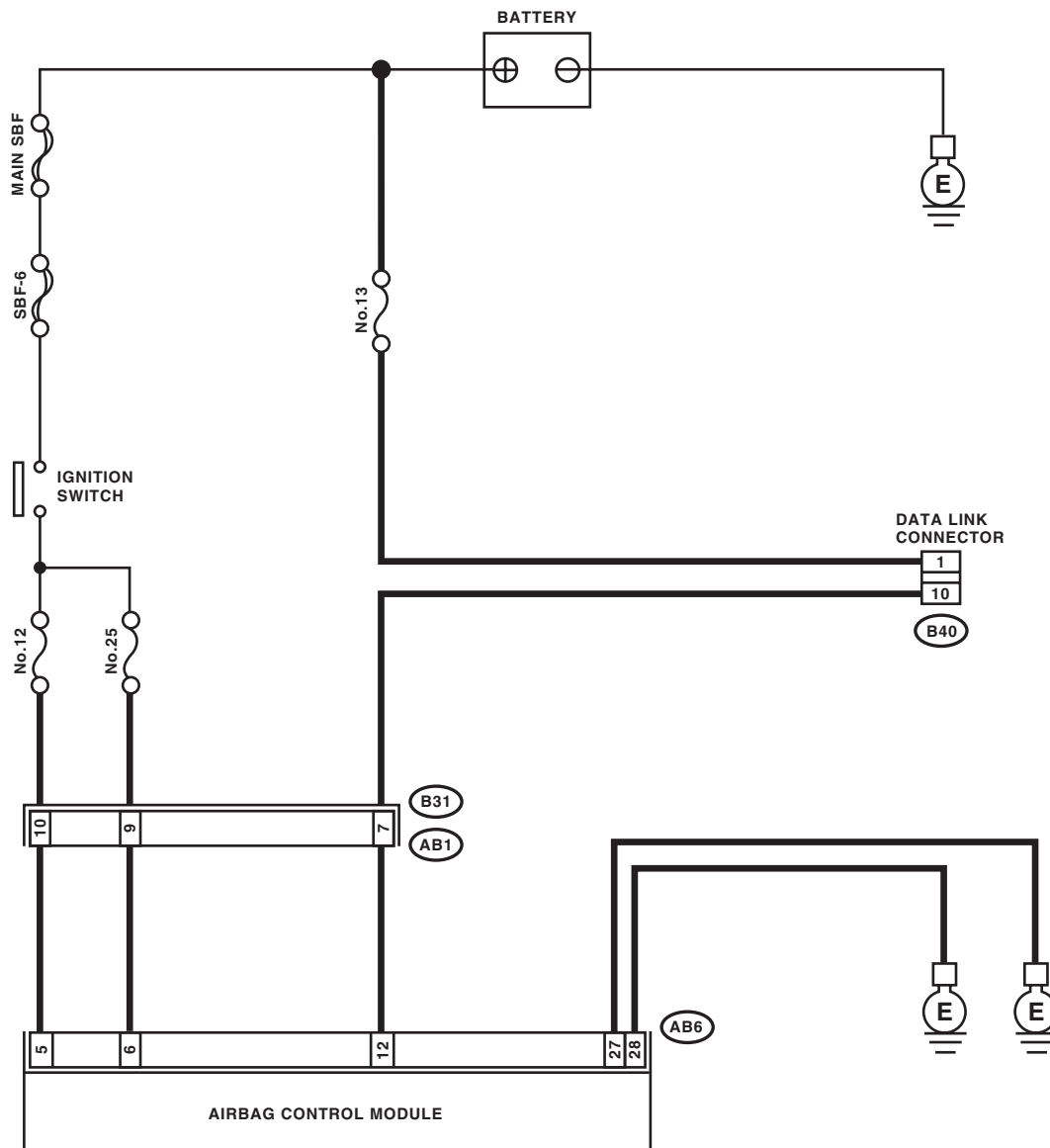

Subaru Select Monitor

AIRBAG SYSTEM (DIAGNOSTICS)

Step	Check	Yes	No	
1	CHECK IGNITION SWITCH.	Is the ignition switch ON?	Go to step 2.	Turn the ignition switch to ON, and select the airbag mode using the Subaru Select Monitor.
2	CHECK BATTERY. 1) Turn the ignition switch to OFF. 2) Measure the battery voltage.	Is the voltage more than 11 V?	Go to step 3.	Charge or replace the battery.
3	CHECK BATTERY TERMINAL.	Is there poor contact at battery terminal?	Repair or tighten the battery terminal.	Go to step 4.
4	CHECK SUBARU SELECT MONITOR COMMUNICATION. 1) Turn the ignition switch to ON. 2) Using the Subaru Select Monitor, check whether communication to other system can be executed normally.	Are the system name and model year displayed on Subaru Select Monitor?	Go to step 9.	Go to step 5.
5	CHECK AIRBAG CONTROL MODULE CONNECTOR. 1) Turn the ignition switch to OFF, disconnect the battery ground cable, and wait more than 20 seconds. 2) Confirm that the connector of airbag control module (AB6) is securely connected.	Is the connector of the airbag control module securely connected?	Go to step 6.	Connect the connector of the airbag control module.
6	CHECK SUBARU SELECT MONITOR COMMUNICATION. 1) Turn the ignition switch to OFF. 2) Disconnect the airbag control module connector. 3) Turn the ignition switch to ON. 4) Check whether communication to other systems can be executed normally.	Are the system name and model year displayed on Subaru Select Monitor?	Replace the airbag control module. <Ref. to AB-23, Airbag Control Module.>	Go to step 7.
7	CHECK HARNESS CONNECTOR BETWEEN EACH CONTROL MODULE AND DATA LINK CONNECTOR. 1) Turn the ignition switch to OFF. 2) Disconnect the airbag control module, ABSCM&H/U, ECM and TCM. 3) Measure the resistance between data link connector and chassis ground. Connector & terminal (B40) No. 10 — Chassis ground:	Is the resistance more than 1 MΩ?	Go to step 8.	Repair the harness and connector between each control module and data link connector. (Replace the harness without repairing the airbag harness.)
8	CHECK OUTPUT SIGNAL TO THE AIRBAG CONTROL MODULE. 1) Turn the ignition switch to ON in the condition of step 7. 2) Measure the voltage between data link connector and chassis ground. Connector & terminal (B40) No. 10 (+) — Chassis ground (-):	Is the voltage less than 1 V?	Go to step 9.	Repair the harness and connector between each control module and data link connector. (Replace the harness without repairing the airbag harness.)

Subaru Select Monitor

AIRBAG SYSTEM (DIAGNOSTICS)

Step	Check	Yes	No
9 CHECK THE HARNESS BETWEEN THE AIRBAG CONTROL MODULE AND DATA LINK CONNECTOR. 1) Turn the ignition switch to OFF, disconnect the battery ground cable, and wait more than 20 seconds. 2) Disconnect the connector (AB6) from airbag control module. 3) Connect the connector (1U) in the test harness U to connector (AB6). 4) Measure the resistance between connector (4U) in the test harness U and the data link connector. Connector & terminal (4U) No. 18 — (B40) No. 10:	Is the resistance less than 10 Ω ?	Go to step 10.	Repair the harness between the airbag control module and the data link connector. Or replace the airbag main harness along with the bulkhead harness.
10 CHECK POWER SUPPLY CIRCUIT. 1) Turn the ignition switch to ON. 2) Measure the voltage between connector (2U) in the test harness U and chassis ground. Connector & terminal (2U) No. 1 — Chassis ground: (2U) No. 6 — Chassis ground:	Is the voltage more than 10 V?	Go to step 11.	Repair the harness between the airbag control module and the battery. Or replace the airbag main harness along with the bulkhead harness.
11 CHECK BETWEEN THE AIRBAG CONTROL MODULE AND CHASSIS GROUND. 1) Turn the ignition switch to OFF. 2) Measure the resistance between connector (2U) in the test harness U and chassis ground. Connector & terminal (2U) No. 10 — Chassis ground: (2U) No. 11 — Chassis ground:	Is the resistance less than 10 Ω ?	Go to step 12.	Repair the harness between the airbag control module and the chassis ground. Or replace the airbag main harness along with the bulkhead harness.
12 CHECK POOR CONTACT IN CONNECTOR.	Is there poor contact in the control module power supply, ground circuit and data link connector?	Repair the connector. (For airbag system connectors, do not repair but replace the entire harness.)	Replace the only airbag control module. <Ref. to AB-23, REMOVAL, Airbag Control Module.>

2. WITHOUT DTC

DETECTING CONDITION:

- Defective combination meter
- Open circuit in harness

TROUBLE SYMPTOM:

- Airbag warning light remains on.
- “NO TROUBLE CODE” will be displayed on the Subaru Select Monitor.

For detailed operation procedure, refer to “Airbag Warning Light Failure”. <Ref. to AB(diag)-38, Airbag Warning Light Failure.>

NOTE:

- For detailed operation procedure, refer to “Airbag Warning Light Failure”. <Ref. to AB(diag)-38, Airbag Warning Light Failure.>
- When the airbag warning light is OFF and “NO TROUBLE CODE” is displayed on Subaru Select Monitor, the system is in normal condition.