

## 13.Side Protector

### A: REMOVAL

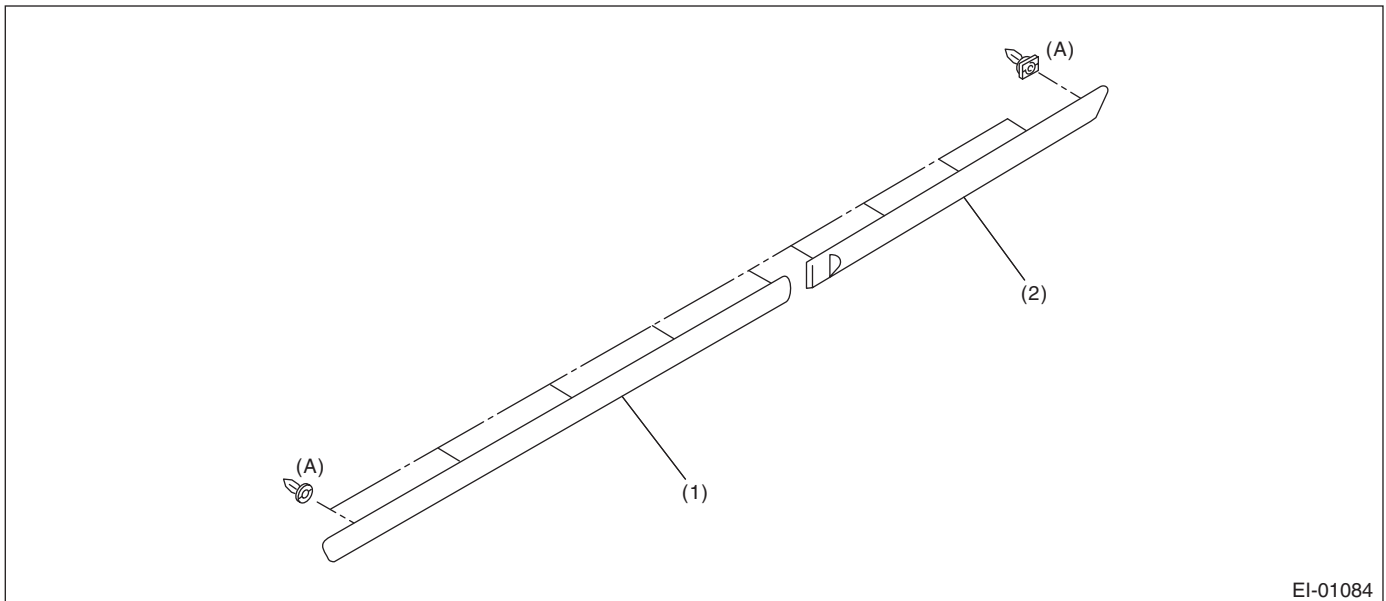

EI-01084

(1) Front door protector

(2) Rear door protector

(A) White clip

1) Slide in a thin thread (A) of 0.8 mm (0.031 in) diameter or less (fishing line etc.) between the body and the protector, and cut the double-sided tape. Pull the protector, and remove the clip using the clip remover.

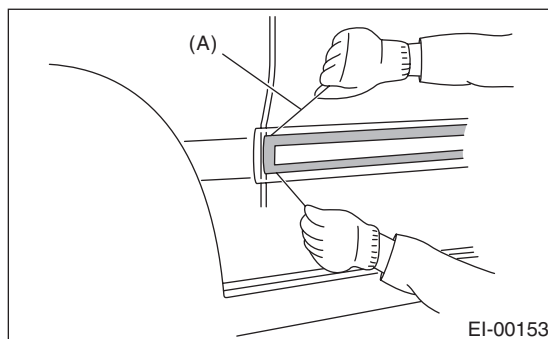

EI-00153

#### NOTE:

- To optimize the effect of solvent, slide the thread along body without removing the double-sided tape on the surface of body and spoiler.
- If it is difficult to remove the double-sided tape, warm it up to approx. 40°C (104°F).
- If the double-sided tape remains thick on the surface due to interfacial peeling, apply solvent after slicing off the double-sided tape using a cutter.

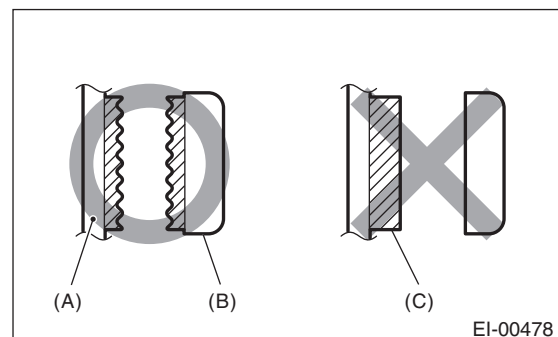

EI-00478

(A) Panel

(B) Side protector

(C) Double-sided tape

2) Apply masking tape around the double-sided tape remaining on the surface of body or spoiler.

3) Apply solvent uniformly on the double-sided tape using a brush.

#### CAUTION:

- Do not use solvent to the body which has been repaired with lacquer paint.
- Wipe off immediately when the solvent is attached on surface of the body or spoiler.

#### Solvent:

**3M 8907 or equivalent**

# Side Protector

## EXTERIOR/INTERIOR TRIM

4) Cover the area where solvent is applied using plastic wrap (A), and then heat the double-sided tape for 5 to 10 minutes in 40 — 60°C (104 — 140°F) using a heat light (B).

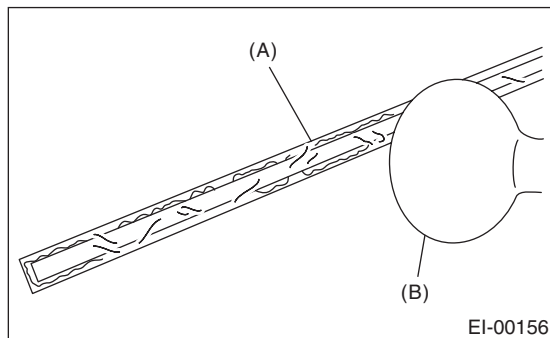
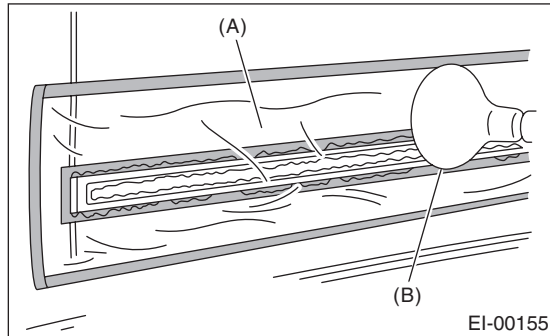

### CAUTION:

**Do not heat the double-sided tape until the surface becomes white and excessively dried.**

5) Remove the double-sided tape using a plastic spatula.

6) After completely removing the double-sided tape, detach the masking tape and clean the surface using a cotton cloth dampened with white gasoline.

## B: INSTALLATION

1) Apply primer to the protector surface where the double-sided tape is to be adhered, and then adhere the double-sided tape as shown in the figure.

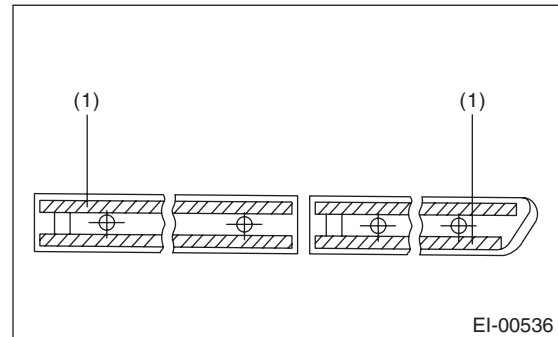

(1) Double-sided tape: thickness 1.2 mm (0.047 in), width 5mm (0.197 in)

### Primer:

**3M K-500 or equivalent**

### Double-sided tape:

**3M 5531-5 or equivalent**

2) Heat the adhering part using a heat light.

Body side: 40 — 60°C (104 — 140°F)

Protector side: 20 — 30°C (68 — 86°F)

3) Peel off the backing sheet of double-sided tape, align the clip position, and then adhere the tape to the body while taking care to avoid air entering.

### CAUTION:

**To keep the adhesion, do not wash the vehicle within 24 hours from installation.**